

SECTION A-A

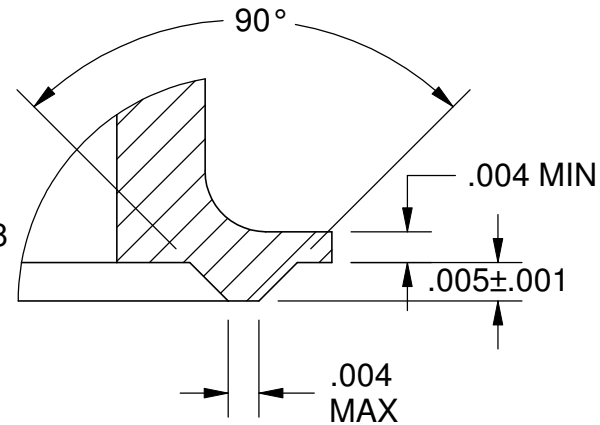

DETAIL A
SCALE 40 : 1

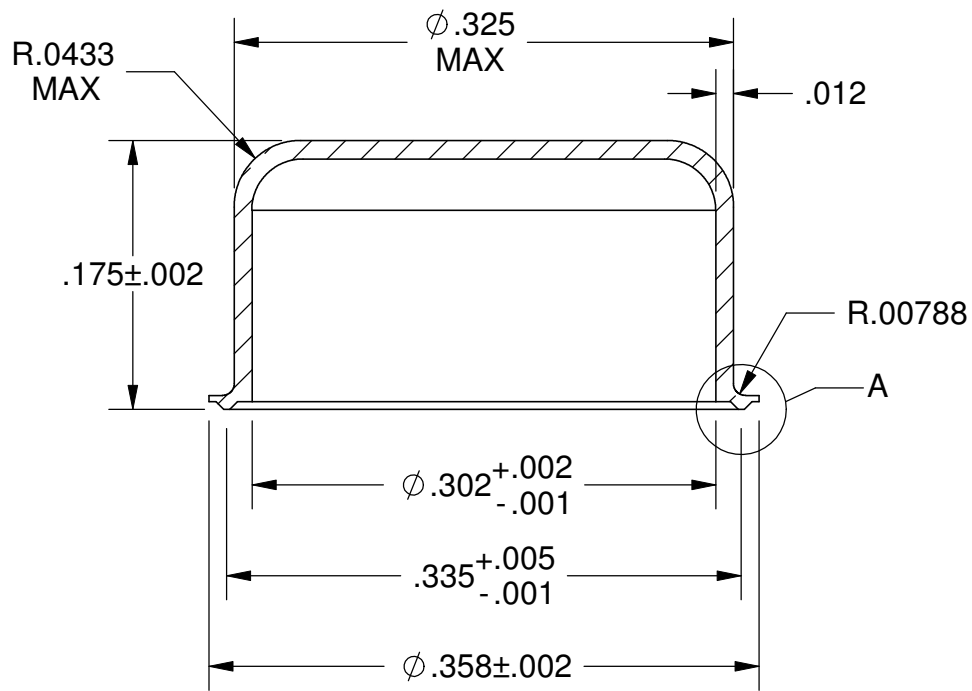
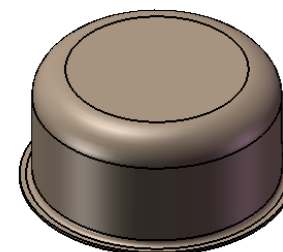
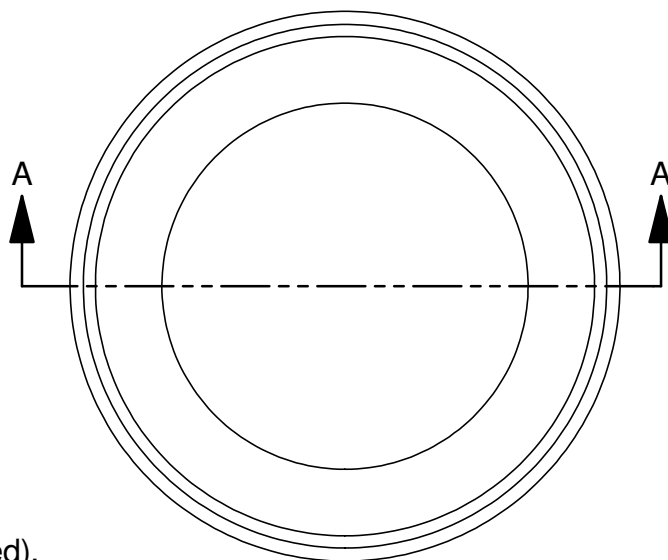

ISOMETRIC VIEW

Notes: (Unless Otherwise Specified).

- 1) CAN - CAP - LID FOR TO-5 AND TO-39.
- 2) NICKEL PLATED.
- 3) WELD PROJECTION.
- 4) DIMENSIONS IN INCH.

APPROVALS		DATE	TopLine ®			
DRAWN	J. Hines	7/27/2014				
ENG	M. Hart	7/27/2014				
MFG			SCALE 8:1	SIZE A	DRAWING NO. 158022	REV A
QA						
CUST			DO NOT SCALE DRAWING		SHEET 1 OF 1	
REVISED						