

### BOTTOM VIEW

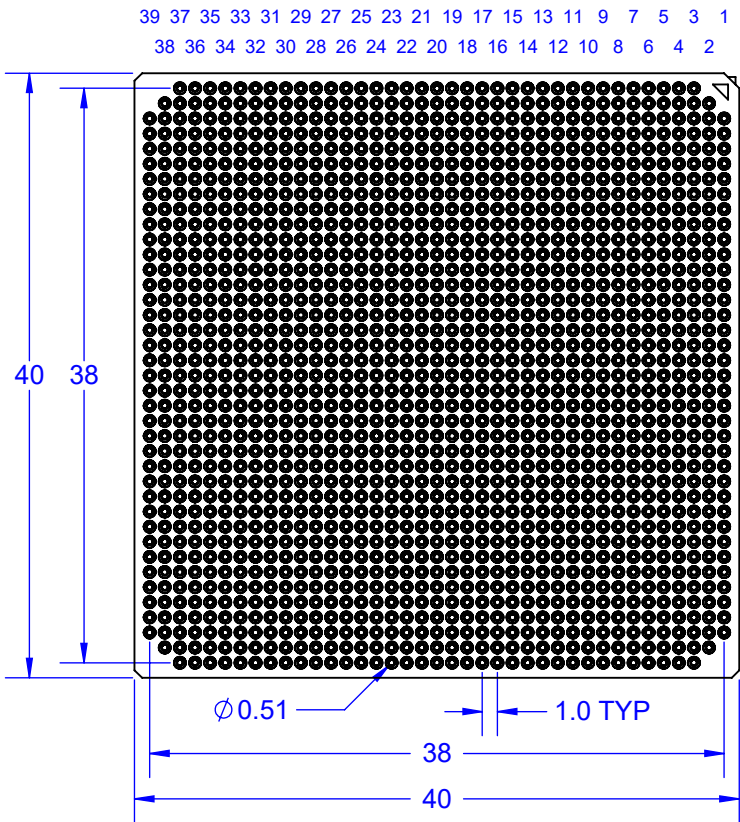

### SIDE VIEW

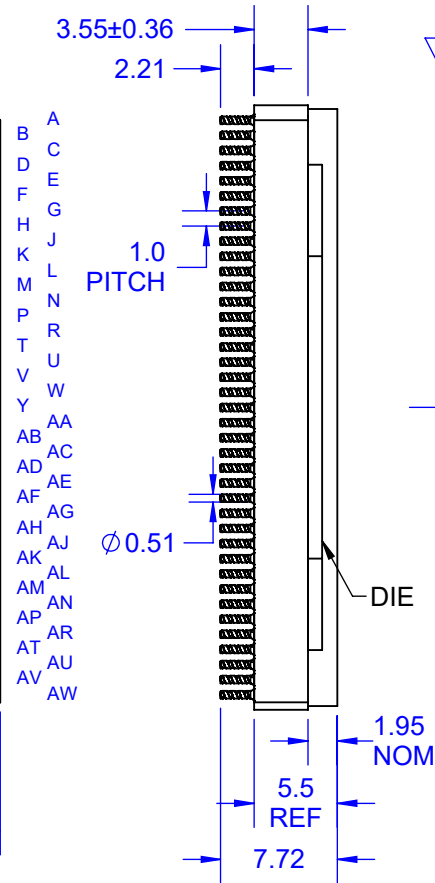

### TOP VIEW

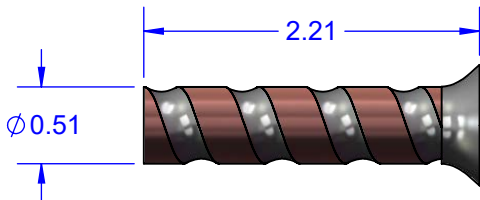
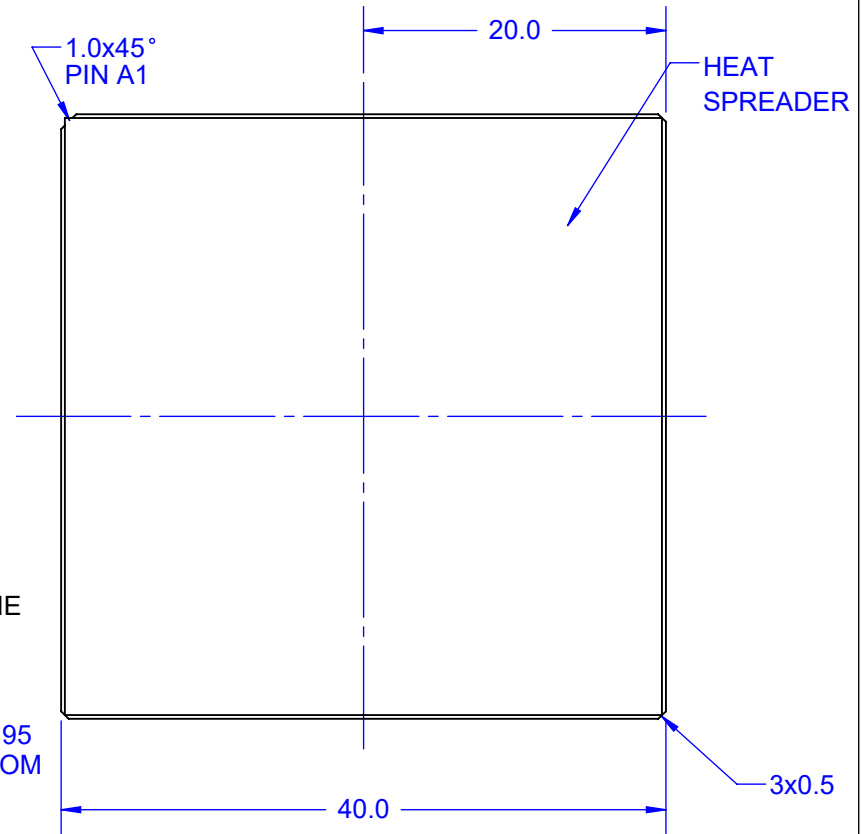

**Cu Wrap Column  
Pb80/Sn20**

NOTES: (Unless Otherwise Specified).

- 1) DIMENSIONS ARE IN mm.
- 2) SHOWN WITH COLUMNS.
- 3) SHOWN WITH CN LID.
- 4) SHOWN WITH DUMMY DIE.
- 5) SHOWN WITHOUT CAPACITORS.
- 6) PART NUMBER CCGA1509T1.0-DC396CN.

PART NUMBER OPTIONS				
PART NUMBER	DUMMY DIE	SOLDER PIN	LID	CAPACITOR
CCGA1509T1.0-DC396CN	YES	Pb80 / Sn20	YES	NONE

APPROVALS		DATE					
DRAWN	T.Au	11/29/2022					
ENG	M. Hart	11/29/2022	TITLE CCGA1509T1.0-DC396CN DAISY CHAIN				
MFG			SCALE 2:1		SIZE A	DRAWING NO. 160178	REV A
QA							
CUST							
REVISED			DO NOT SCALE DRAWING			SHEET 1 OF 11	

# DAISY CHAIN PATTERN PAD (COLUMN VIEW)

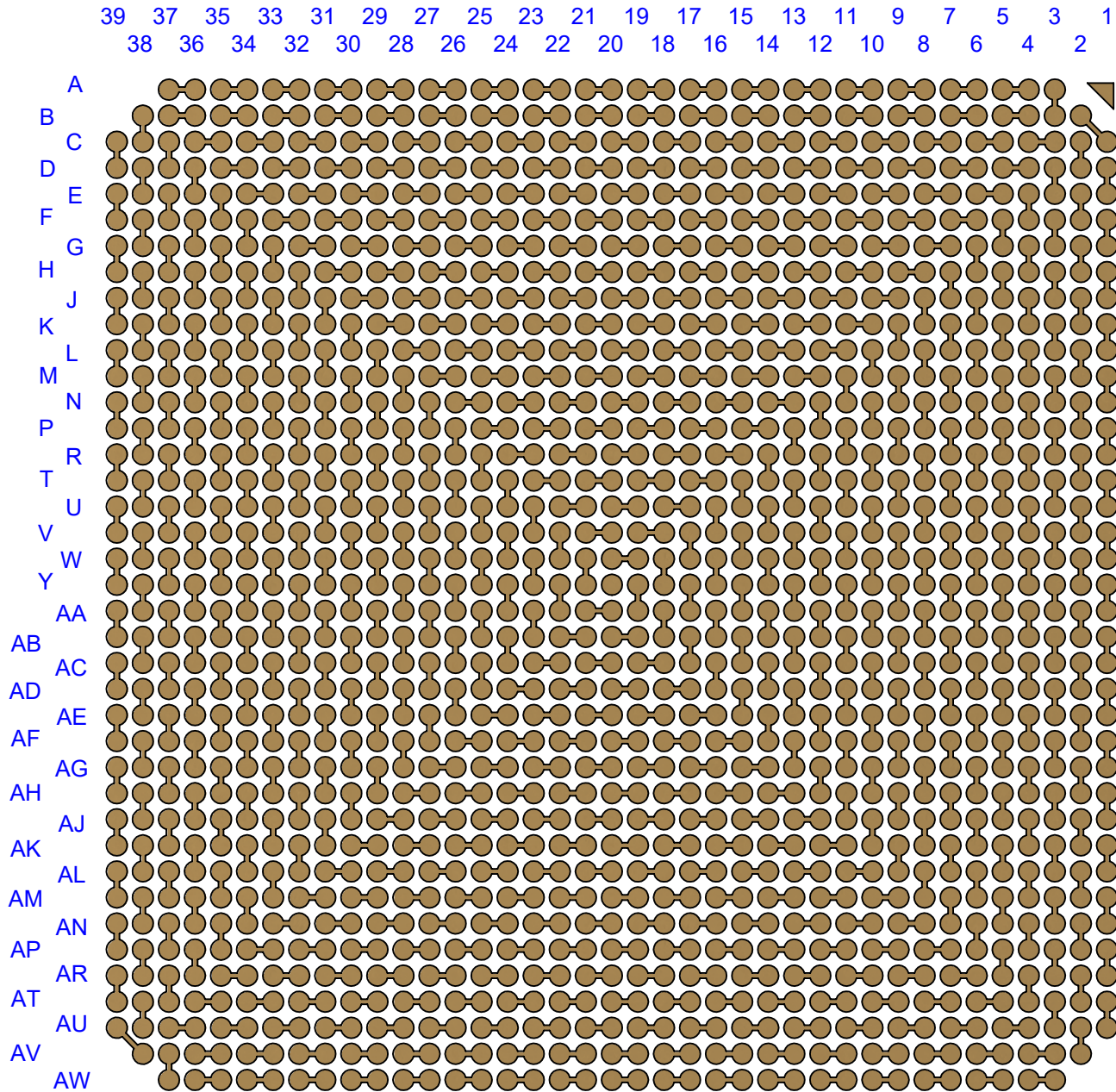

<b>TopLine®</b>			
TITLE    CCGA1509T1.0-DC396CN DAISY CHAIN			
SCALE 4:1	SIZE A	DRAWING NO. 160178	REV A
DO NOT SCALE DRAWING			SHEET 2 OF 11

# DAISY CHAIN PATTERN BOTTOM X-RAY VIEWED FROM TOP

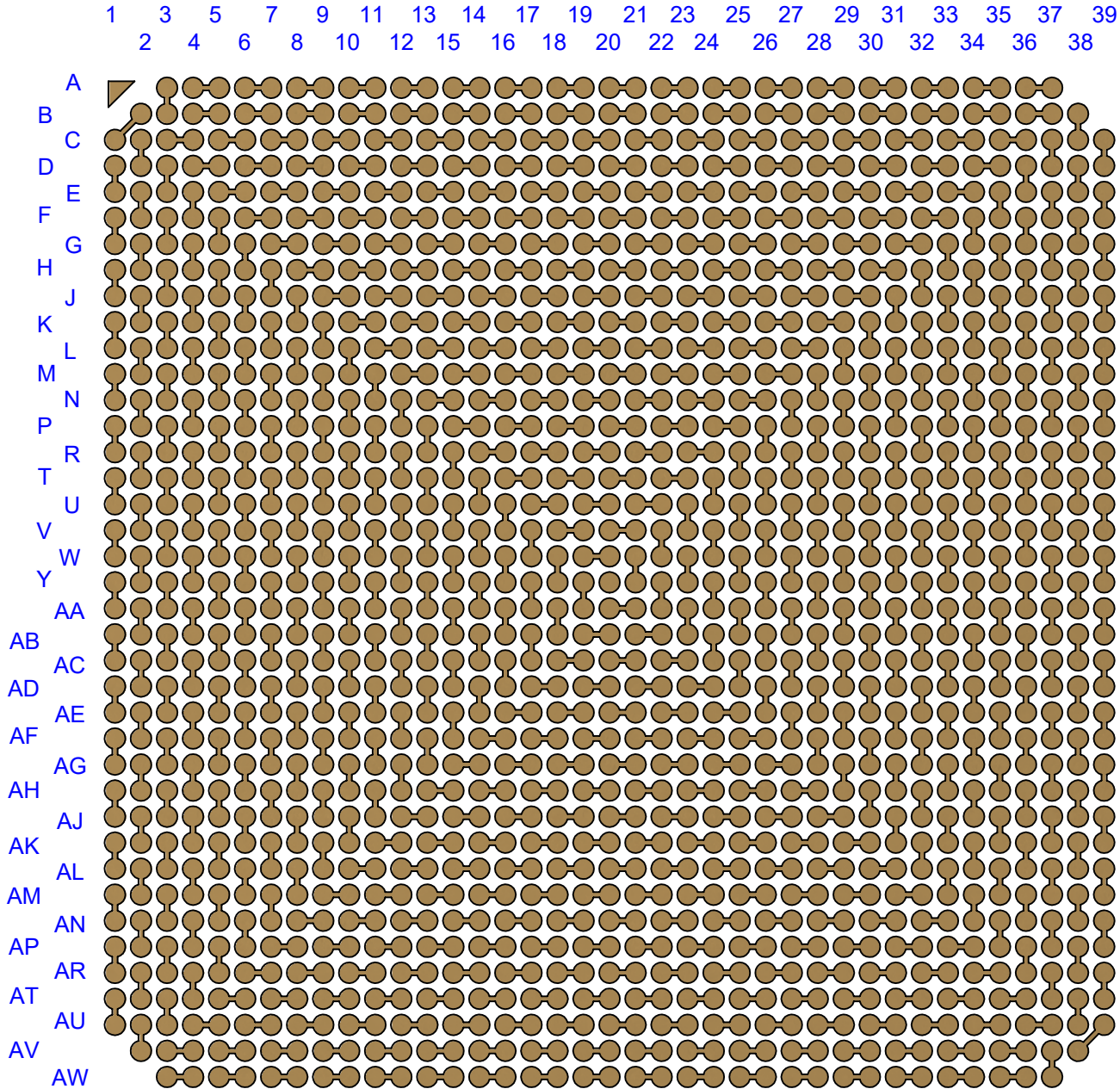

<b>TopLine®</b>			
TITLE CCGA1509T1.0-DC396CN DAISY CHAIN			
SCALE 4:1	SIZE A	DRAWING NO. 160178	REV A
DO NOT SCALE DRAWING			SHEET 3 OF 11

# SOLDER PIN OPTIONS

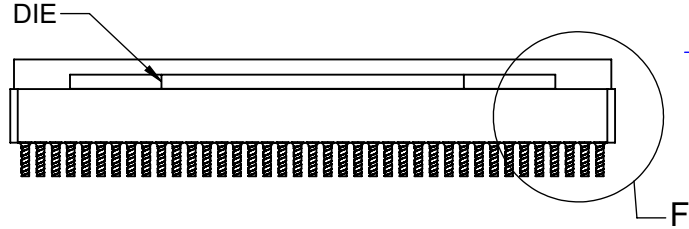

DETAIL F  
SCALE 6 : 1

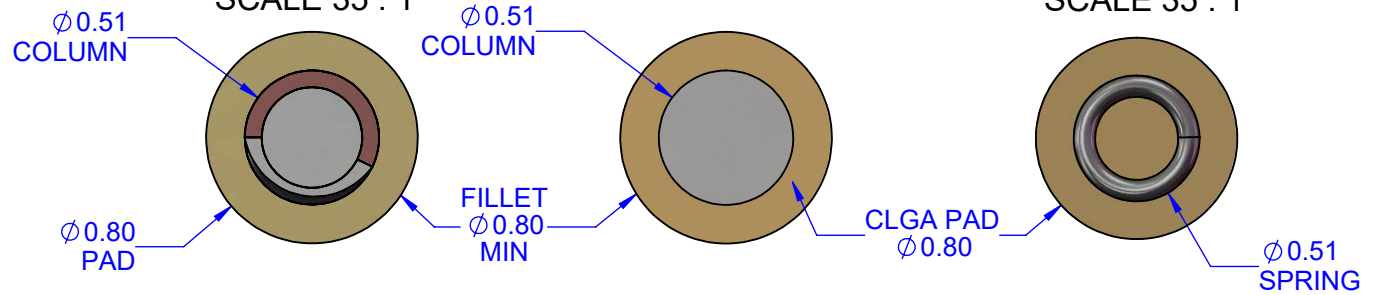
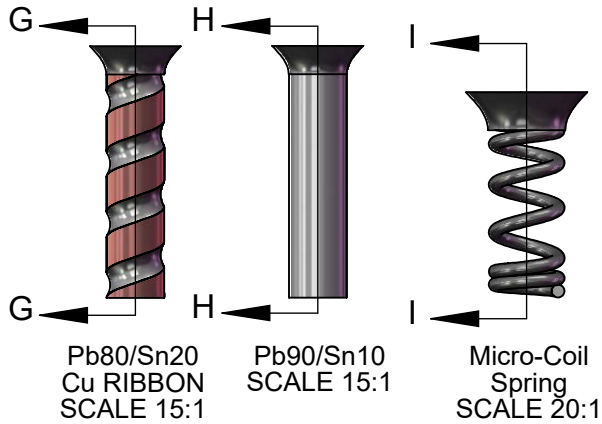
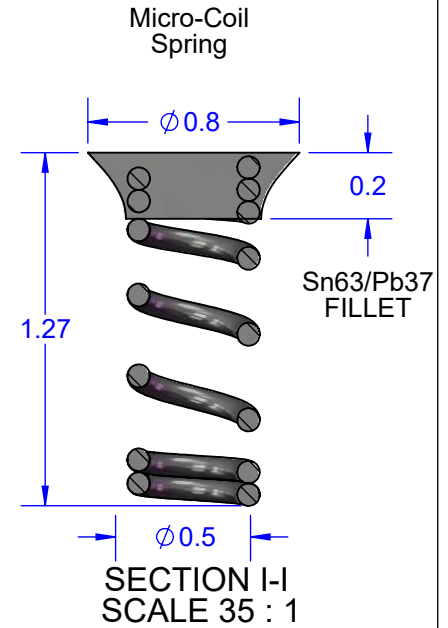
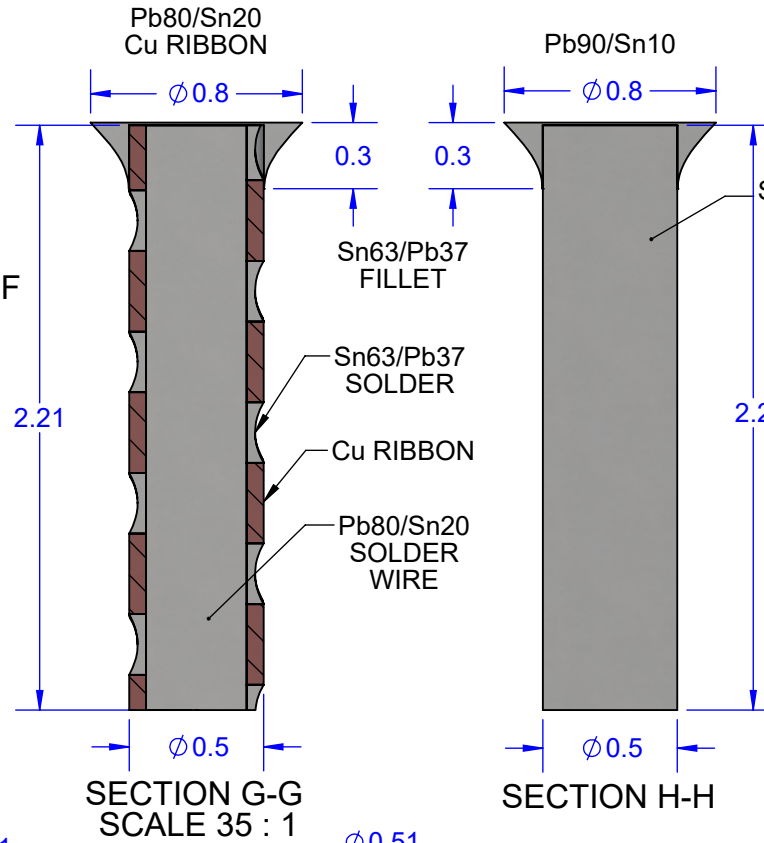

<b>TopLine®</b>			
TITLE CCGA1509T1.0-DC396CN DAISY CHAIN			
SCALE 2:1	SIZE A	DRAWING NO. 160178	REV A
DO NOT SCALE DRAWING			SHEET 4 OF 11

## DAISY CHAIN NET LIST

DC PAIR	
D1	E1
F1	G1
H1	J1
K1	L1
M1	N1
P1	R1
T1	U1
V1	W1
Y1	AA1
AB1	AC1
AD1	AE1
AF1	AG1
AH1	AJ1
AK1	AL1
AM1	AN1
AP1	AR1
AT1	AU1
C2	D2
E2	F2
G2	H2
J2	K2
L2	M2
N2	P2
R2	T2
U2	V2
W2	Y2
AA2	AB2

DC PAIR	
AC2	AD2
AE2	AF2
AG2	AH2
AJ2	AK2
AL2	AM2
AN2	AP2
AR2	AT2
AU2	AV2
A3	B3
B2	C1
D3	E3
F3	G3
H3	J3
K3	L3
M3	N3
P3	R3
T3	U3
V3	W3
Y3	AA3
AB3	AC3
AD3	AE3
AF3	AG3
AH3	AJ3
AK3	AL3
AM3	AN3
AP3	AR3
AT3	AU3

DC PAIR	
C3	C4
E4	F4
G4	H4
J4	K4
L4	M4
N4	P4
R4	T4
U4	V4
W4	Y4
AA4	AB4
AC4	AD4
AE4	AF4
AG4	AH4
AJ4	AK4
AL4	AM4
AN4	AP4
AR4	AT4
AV3	AV4
AW3	AW4
A4	A5
B4	B5
D4	D5
F5	G5
H5	J5
K5	L5
M5	N5
P5	R5
T5	U5

DC PAIR	
V5	W5
Y5	AA5
AB5	AC5
AD5	AE5
AF5	AG5
AH5	AJ5
AK5	AL5
AM5	AN5
AP5	AR5
AU4	AU5
C5	C6
E5	E6
G6	H6
J6	K6
L6	M6
N6	P6
R6	T6
U6	V6
W6	Y6
AA6	AB6
AC6	AD6
AE6	AF6
AG6	AH6
AJ6	AK6
AL6	AM6
AN6	AP6
AT5	AT6
AV5	AV6

DC PAIR	
AW5	AW6
A6	A7
B6	B7
D6	D7
F6	F7
H7	J7
K7	L7
M7	N7
P7	R7
T7	U7
V7	W7
Y7	AA7
AB7	AC7
AD7	AE7
AF7	AG7
AH7	AJ7
AK7	AL7
AM7	AN7
AR6	AR7
AU6	AU7
C7	C8
E7	E8
G7	G8
J8	K8
L8	M8
N8	P8
R8	T8
U8	V8

DC PAIR	
W8	Y8
AA8	AB8
AC8	AD8
AE8	AF8
AG8	AH8
AJ8	AK8
AL8	AM8
AP7	AP8
AT7	AT8
AV7	AV8
AW7	AW8
A8	A9
B8	B9
D8	D9
F8	F9
H8	H9
K9	L9
M9	N9
P9	R9
T9	U9
V9	W9
Y9	AA9
AB9	AC9
AD9	AE9
AF9	AG9
AH9	AJ9
AK9	AL9
AN8	AN9

DC PAIR	
AR8	AR9
AU8	AU9
C9	C10
E9	E10
G9	G10
J9	J10
L10	M10
N10	P10
R10	T10
U10	V10
W10	Y10
AA10	AB10
AC10	AD10
AE10	AF10
AG10	AH10
AJ10	AK10
AM9	AM10
AP9	AP10
AT9	AT10
AV9	AV10
AW9	AW10
A10	A11
B10	B11

DC PAIR	
D10	D11
F10	F11
H10	H11
K10	K11
M11	N11
P11	R11
T11	U11
V11	W11
Y11	AA11
AB11	AC11
AD11	AE11
AF11	AG11
AH11	AJ11
AL10	AL11
AN10	AN11
AR10	AR11
AU10	AU11
C11	C12
E11	E12
G11	G12
J11	J12
L11	L12
N12	P12

<b>TopLine®</b>			
TITLE    CCGA1509T1.0-DC396CN DAISY CHAIN			
SCALE NONE	SIZE A	DRAWING NO. 160178	REV A
DO NOT SCALE DRAWING			SHEET 5 OF 11

## DAISY CHAIN NET LIST

DC PAIR	
R12	T12
U12	V12
W12	Y12
AA12	AB12
AC12	AD12
AE12	AF12
AG12	AH12
AK11	AK12
AM11	AM12
AP11	AP12
AT11	AT12
AV11	AV12
AW11	AW12
A12	A13
B12	B13
D12	D13
F12	F13
H12	H13
K12	K13
M12	M13
P13	R13
T13	U13
V13	W13
Y13	AA13
AB13	AC13
AD13	AE13
AF13	AG13
AJ12	AJ13

DC PAIR	
AL12	AL13
AN12	AN13
AR12	AR13
AU12	AU13
C13	C14
E13	E14
G13	G14
J13	J14
L13	L14
N13	N14
R14	T14
U14	V14
W14	Y14
AA14	AB14
AC14	AD14
AE14	AF14
AH13	AH14
AK13	AK14
AM13	AM14
AP13	AP14
AT13	AT14
AV13	AV14
AW13	AW14
A14	A15
B14	B15
D14	D15
F14	F15
H14	H15

DC PAIR	
K14	K15
M14	M15
P14	P15
T15	U15
V15	W15
Y15	AA15
AB15	AC15
AD15	AE15
AG14	AG15
AJ14	AJ15
AL14	AL15
AN14	AN15
AR14	AR15
AU14	AU15
C15	C16
E15	E16
G15	G16
J15	J16
L15	L16
N15	N16
R15	R16
U16	V16
W16	Y16
AA16	AB16
AC16	AD16
AF15	AF16
AH15	AH16
AK15	AK16

DC PAIR	
AM15	AM16
AP15	AP16
AT15	AT16
AV15	AV16
AW15	AW16
A16	A17
B16	B17
D16	D17
F16	F17
H16	H17
K16	K17
M16	M17
P16	P17
T16	T17
V17	W17
Y17	AA17
AB17	AC17
AE16	AE17
AG16	AG17
AJ16	AJ17
AL16	AL17
AN16	AN17
AR16	AR17
AU16	AU17
C17	C18
E17	E18
G17	G18
J17	J18

DC PAIR	
L17	L18
N17	N18
R17	R18
U17	U18
W18	Y18
AA18	AB18
AD17	AD18
AF17	AF18
AH17	AH18
AK17	AK18
AM17	AM18
AP17	AP18
AT17	AT18
AV17	AV18
AW17	AW18
A18	A19
B18	B19
D18	D19
F18	F19
H18	H19
K18	K19
M18	M19
P18	P19
T18	T19
V18	V19
Y19	AA19
AC18	AC19
AE18	AE19

DC PAIR	
AG18	AG19
AJ18	AJ19
AL18	AL19
AN18	AN19
AR18	AR19
AU18	AU19
C19	C20
E19	E20
G19	G20
J19	J20
L19	L20
N19	N20
R19	R20
U19	U20
W19	W20
AB19	AB20
AD19	AD20
AF19	AF20
AH19	AH20
AK19	AK20
AM19	AM20
AP19	AP20
AT19	AT20
AV19	AV20
AW19	AW20
A20	A21
B20	B21
D20	D21

DC PAIR	
F20	F21
H20	H21
K20	K21
M20	M21
P20	P21
T20	T21
V20	V21
W21	Y21
AA20	AA21
AC20	AC21
AE20	AE21
AG20	AG21
AJ20	AJ21
AL20	AL21
AN20	AN21
AR20	AR21
AU20	AU21
C21	C22
E21	E22
G21	G22
J21	J22
L21	L22
N21	N22

DC PAIR	
R21	R22
U21	U22
V22	W22
Y22	AA22
AB21	AB22
AD21	AD22
AF21	AF22
AH21	AH22
AK21	AK22
AM21	AM22
AP21	AP22
AT21	AT22
AV21	AV22
AW21	AW22
A22	A23
B22	B23
D22	D23
F22	F23
H22	H23
K22	K23
M22	M23
P22	P23
T22	T23

<b>TopLine®</b>			
TITLE CCGA1509T1.0-DC396CN DAISY CHAIN			
SCALE NONE	SIZE A	DRAWING NO. 160178	REV A
DO NOT SCALE DRAWING			SHEET 6 OF 11

## DAISY CHAIN NET LIST

DC PAIR	
U23	V23
W23	Y23
AA23	AB23
AC22	AC23
AE22	AE23
AG22	AG23
AJ22	AJ23
AL22	AL23
AN22	AN23
AR22	AR23
AU22	AU23
C23	C24
E23	E24
G23	G24
J23	J24
L23	L24
N23	N24
R23	R24
T24	U24
V24	W24
Y24	AA24
AB24	AC24
AD23	AD24
AF23	AF24
AH23	AH24
AK23	AK24
AM23	AM24
AP23	AP24

DC PAIR	
AT23	AT24
AV23	AV24
AW23	AW24
A24	A25
B24	B25
D24	D25
F24	F25
H24	H25
K24	K25
M24	M25
P24	P25
R25	T25
U25	V25
W25	Y25
AA25	AB25
AC25	AD25
AE24	AE25
AG24	AG25
AJ24	AJ25
AL24	AL25
AN24	AN25
AR24	AR25
AU24	AU25
C25	C26
E25	E26
G25	G26
J25	J26
L25	L26

DC PAIR	
N25	N26
P26	R26
T26	U26
V26	W26
Y26	AA26
AB26	AC26
AD26	AE26
AF25	AF26
AH25	AH26
AK25	AK26
AM25	AM26
AP25	AP26
AT25	AT26
AV25	AV26
AW25	AW26
A26	A27
B26	B27
D26	D27
F26	F27
H26	H27
K26	K27
M26	M27
N27	P27
R27	T27
U27	V27
W27	Y27
AA27	AB27
AC27	AD27

DC PAIR	
AE27	AF27
AG26	AG27
AJ26	AJ27
AL26	AL27
AN26	AN27
AR26	AR27
AU26	AU27
C27	C28
E27	E28
G27	G28
J27	J28
L27	L28
M28	N28
P28	R28
T28	U28
V28	W28
Y28	AA28
AB28	AC28
AD28	AE28
AF28	AG28
AH27	AH28
AK27	AK28
AM27	AM28
AP27	AP28
AT27	AT28
AV27	AV28
AW27	AW28
A28	A29

DC PAIR	
B28	B29
D28	D29
F28	F29
H28	H29
K28	K29
L29	M29
N29	P29
R29	T29
U29	V29
W29	Y29
AA29	AB29
AC29	AD29
AE29	AF29
AG29	AH29
AJ28	AJ29
AL28	AL29
AN28	AN29
AR28	AR29
AU28	AU29
C29	C30
E29	E30
G29	G30
J29	J30
K30	L30
M30	N30
P30	R30
T30	U30
V30	W30

DC PAIR	
Y30	AA30
AB30	AC30
AD30	AE30
AF30	AG30
AH30	AJ30
AK29	AK30
AM29	AM30
AP29	AP30
AT29	AT30
AV29	AV30
AW29	AW30
A30	A31
B30	B31
D30	D31
F30	F31
H30	H31
J31	K31
L31	M31
N31	P31
R31	T31
U31	V31
W31	Y31
AA31	AB31
AC31	AD31
AE31	AF31
AG31	AH31
AJ31	AK31
AL30	AL31

DC PAIR	
AN30	AN31
AR30	AR31
AU30	AU31
C31	C32
E31	E32
G31	G32
H32	J32
K32	L32
M32	N32
P32	R32
T32	U32
V32	W32
Y32	AA32
AB32	AC32
AD32	AE32
AF32	AG32
AH32	AJ32
AK32	AL32
AM31	AM32
AP31	AP32
AT31	AT32
AV31	AV32
AW31	AW32

DC PAIR	
A32	A33
B32	B33
D32	D33
F32	F33
G33	H33
J33	K33
L33	M33
N33	P33
R33	T33
U33	V33
W33	Y33
AA33	AB33
AC33	AD33
AE33	AF33
AG33	AH33
AJ33	AK33
AL33	AM33
AN32	AN33
AR32	AR33
AU32	AU33
C33	C34
E33	E34
F34	G34

<b>TopLine®</b>			
TITLE CCGA1509T1.0-DC396CN DAISY CHAIN			
SCALE NONE	SIZE A	DRAWING NO. 160178	REV A
DO NOT SCALE DRAWING			SHEET 7 OF 11

## DAISY CHAIN NET LIST

DC PAIR	
H34	J34
K34	L34
M34	N34
P34	R34
T34	U34
V34	W34
Y34	AA34
AB34	AC34
AD34	AE34
AF34	AG34
AH34	AJ34
AK34	AL34
AM34	AN34
AP33	AP34
AT33	AT34
AV33	AV34
AW33	AW34
A34	A35
B34	B35
D34	D35
E35	F35
G35	H35
J35	K35
L35	M35
N35	P35
R35	T35
U35	V35
W35	Y35

DC PAIR	
AA35	AB35
AC35	AD35
AE35	AF35
AG35	AH35
AJ35	AK35
AL35	AM35
AN35	AP35
AR34	AR35
AU34	AU35
C35	C36
D36	E36
F36	G36
H36	J36
K36	L36
M36	N36
P36	R36
T36	U36
V36	W36
Y36	AA36
AB36	AC36
AD36	AE36
AF36	AG36
AH36	AJ36
AK36	AL36
AM36	AN36
AP36	AR36
AT35	AT36
AV35	AV36

DC PAIR	
AW35	AW36
A36	A37
B36	B37
C37	D37
E37	F37
G37	H37
J37	K37
L37	M37
N37	P37
R37	T37
U37	V37
W37	Y37
AA37	AB37
AC37	AD37
AE37	AF37
AG37	AH37
AJ37	AK37
AL37	AM37
AN37	AP37
AR37	AT37
AU36	AU37
B38	C38
D38	E38
F38	G38
H38	J38
K38	L38
M38	N38
P38	R38

DC PAIR	
T38	U38
V38	W38
Y38	AA38
AB38	AC38
AD38	AE38
AF38	AG38
AH38	AJ38
AK38	AL38
AM38	AN38
AP38	AR38
AT38	AU38
AV37	AW37
C39	D39
E39	F39
G39	H39
J39	K39
L39	M39
N39	P39
R39	T39
U39	V39
W39	Y39
AA39	AB39
AC39	AD39
AE39	AF39
AG39	AH39
AJ39	AK39
AL39	AM39
AN39	AP39

DC PAIR	
AR39	AT39
AU39	AV38
Y20	NO PAIR



<b>TopLine®</b> TITLE CCGA1509T1.0-DC396CN DAISY CHAIN			
SCALE NONE	SIZE A	DRAWING NO. 160178	REV A
DO NOT SCALE DRAWING		SHEET 8 OF 11	



**CCGA1509T1.0-DC396CN**  
**Pb80 Sn20 COLUMNS**

**TOP**

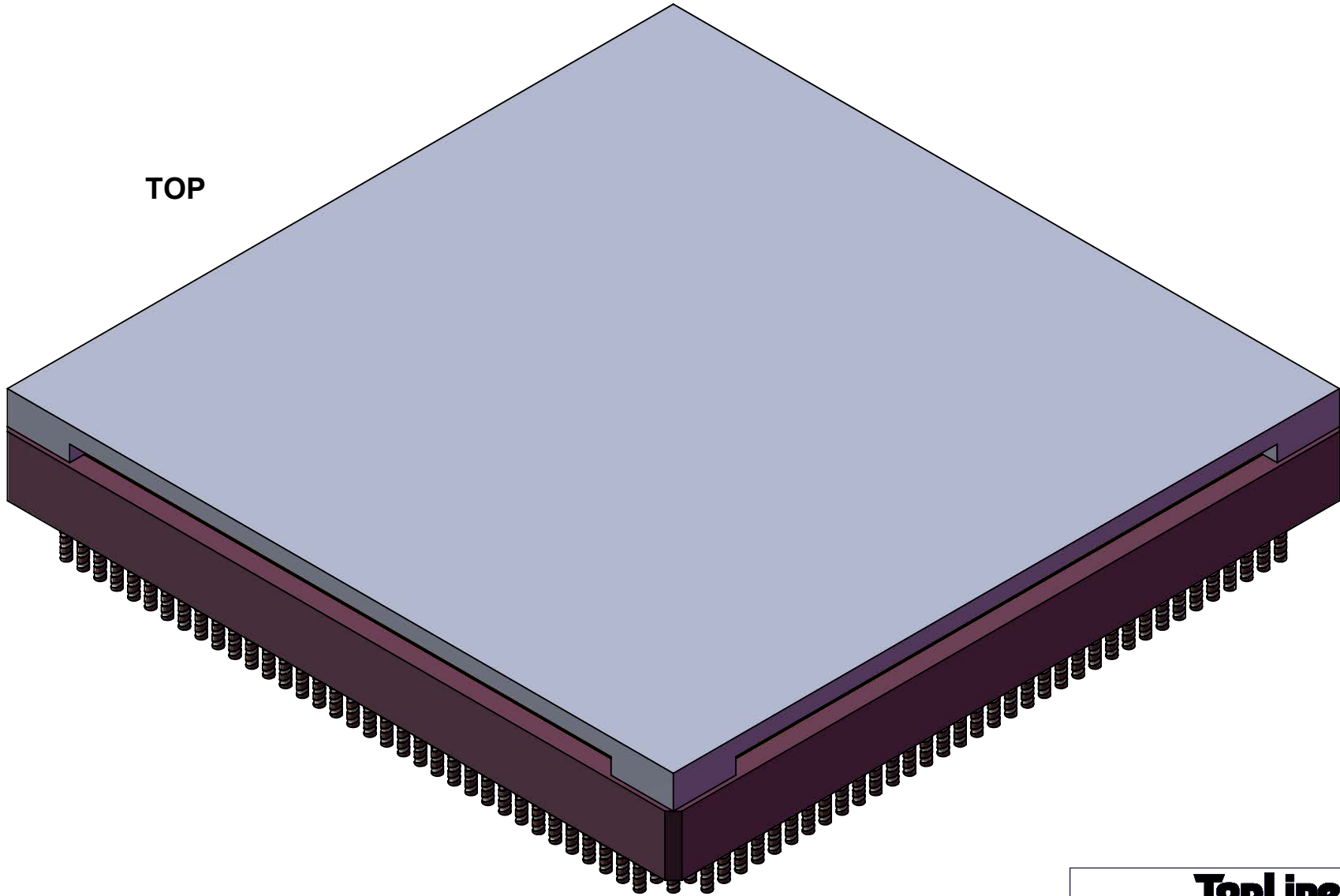

**TopLine®**

TITLE CCGA1509T1.0-DC396CN  
DAISY CHAIN

SCALE 4:1	SIZE A	DRAWING NO. 160178	REV A
--------------	-----------	-----------------------	----------

DO NOT SCALE DRAWING

SHEET 9 OF 11

CCGA1509T1.0-DC396CN  
Pb80 Sn20 COLUMNS

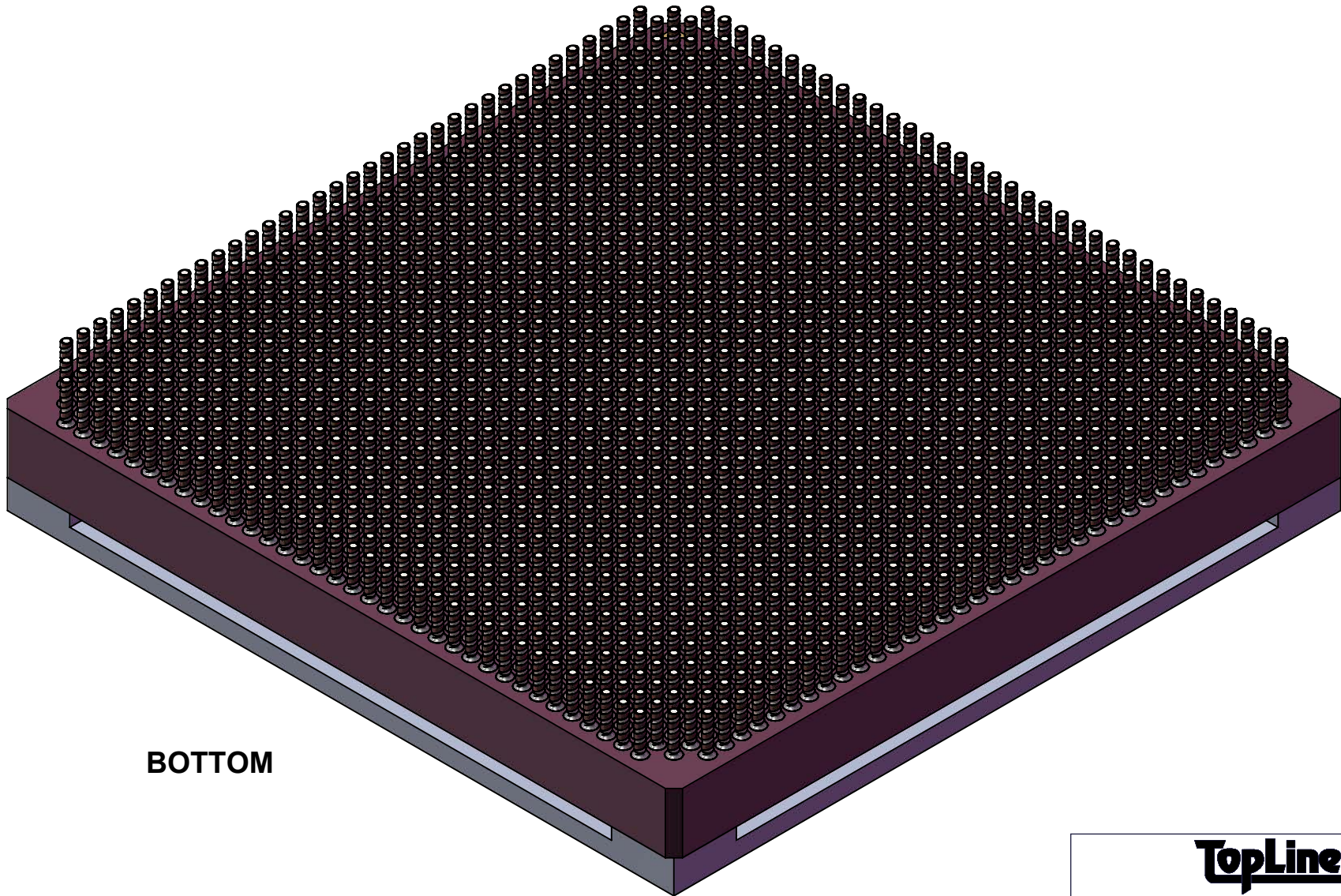

BOTTOM

**TopLine**<sup>®</sup>

TITLE CCGA1509T1.0-DC396CN  
DAISY CHAIN

SCALE 4:1	SIZE A	DRAWING NO. 160178	REV A
--------------	-----------	-----------------------	----------

DO NOT SCALE DRAWING

SHEET 10 OF 11

### BOTTOM VIEW

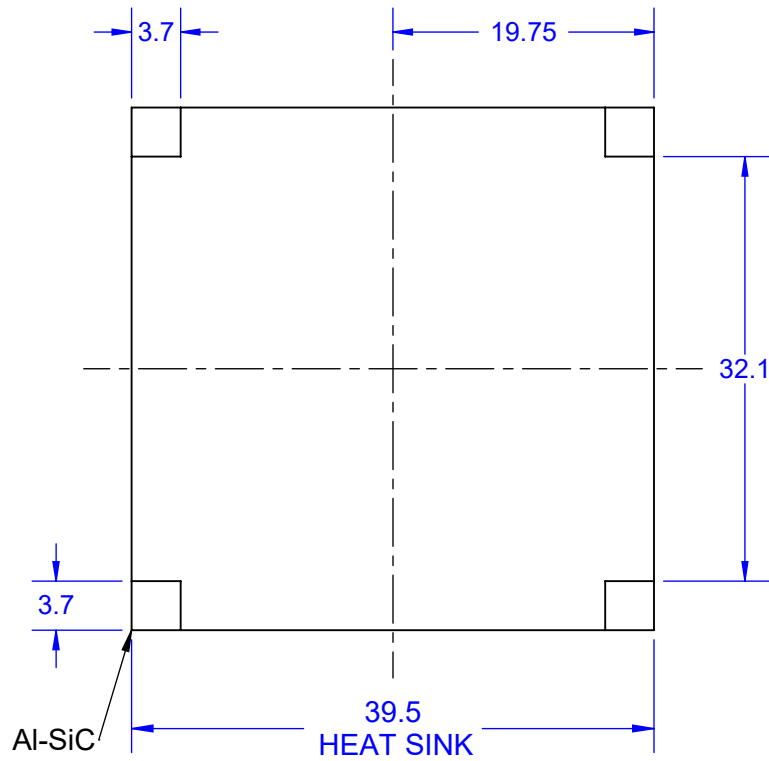

### DETAIL E AlSiC HEAT SINK

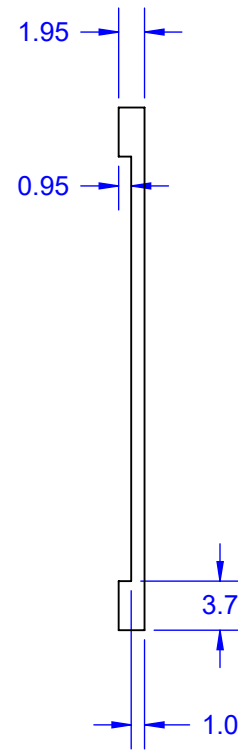

### TOP VIEW

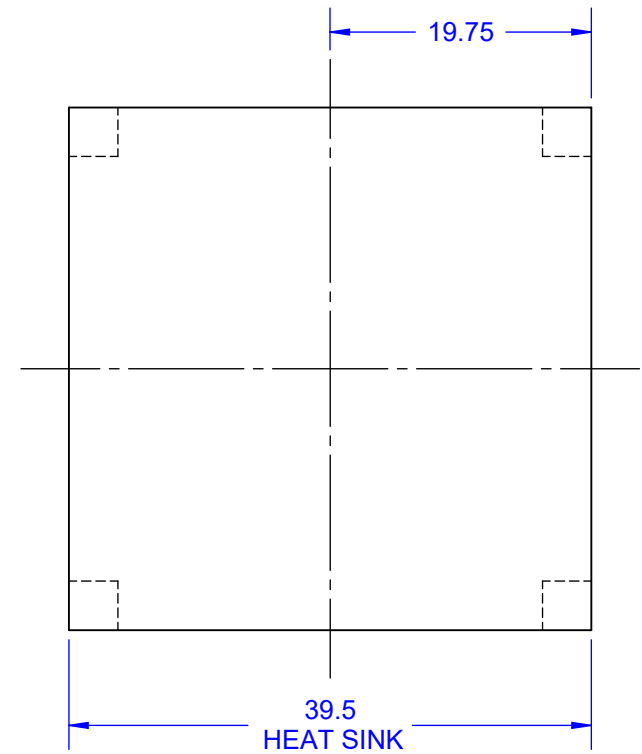

**BOTTOM**

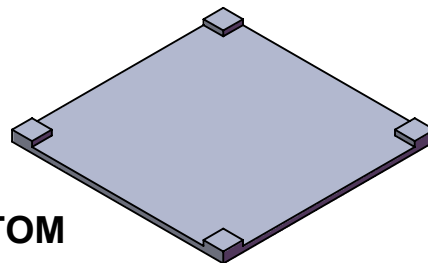

**MODELS**

**TOP**

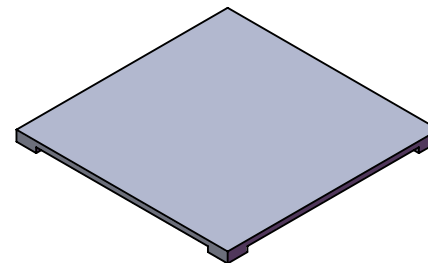

- NOTES ABOUT HEAT SINK:  
 1. DIMENSIONS IN mm.  
 2. MATERIAL: Al-SiC HEAT SINK.  
 3. NON HERMETIC.

<b>TopLine®</b>			
TITLE CCGA1509T1.0-DC396CN DAISY CHAIN			
SCALE 1.75:1	SIZE A	DRAWING NO. 160178	REV A
DO NOT SCALE DRAWING			SHEET 11 OF 11