

BOTTOM VIEW

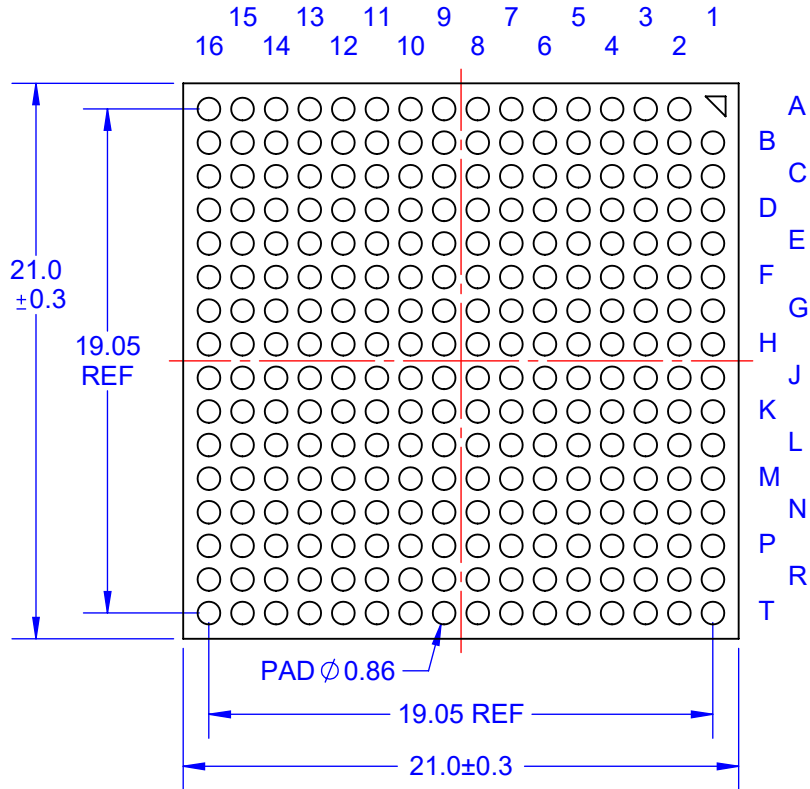

Pb80/Sn20
Cu WRAP COLUMN

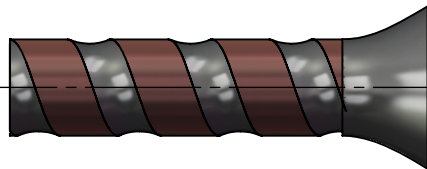

TOP VIEW

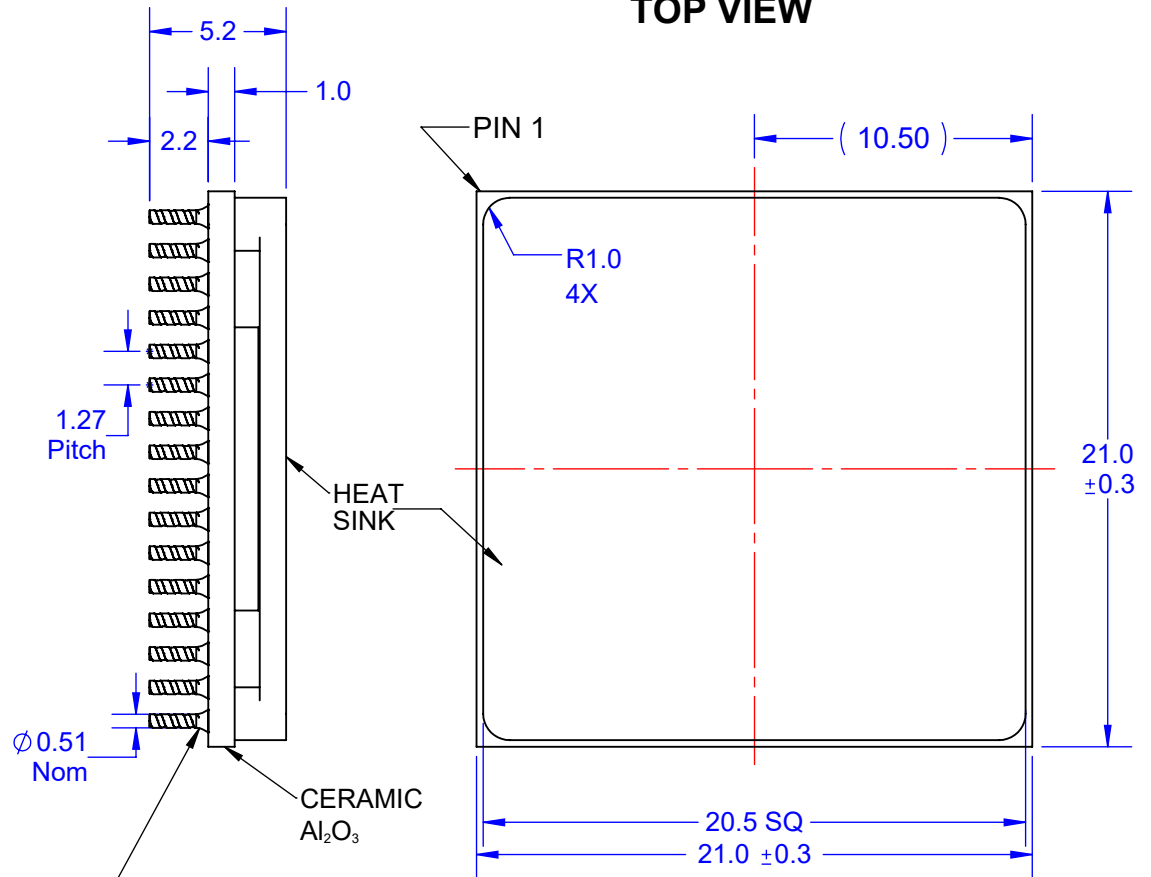

Notes: (Unless Otherwise Specified)

- 1) DIMENSION ARE IN mm.
- 2) SHOWN WITH Pb80/Sn20 Cu .
- 3) 255 COLUMNS.
- 4) DIE SIZE 10 x 7.8 x 0.9 MM.
- 5) PART NUMBER CCGA255T1.27-CN.

PART NUMBER OPTIONS

PART NUMBER	DUMMY DIE	SOLDER PIN	HEATSINK
CCGA255T1.27-CN	YES	Pb80/Sn20 Cu RIBBON	YES

APPROVALS	DATE	TopLine®			
DRAWN T.Au	6/20/2021				
ENG M. Hart	6/20/2021	TITLE CCGA255T1.27-CN COLUMN GRID ARRAY			
MFG		SCALE 3.5:1	SIZE A	DRAWING NO. 160032	REV A
QA		DO NOT SCALE DRAWING			SHEET 1 OF 11
CUST					
REVISED					

BOTTOM VIEW

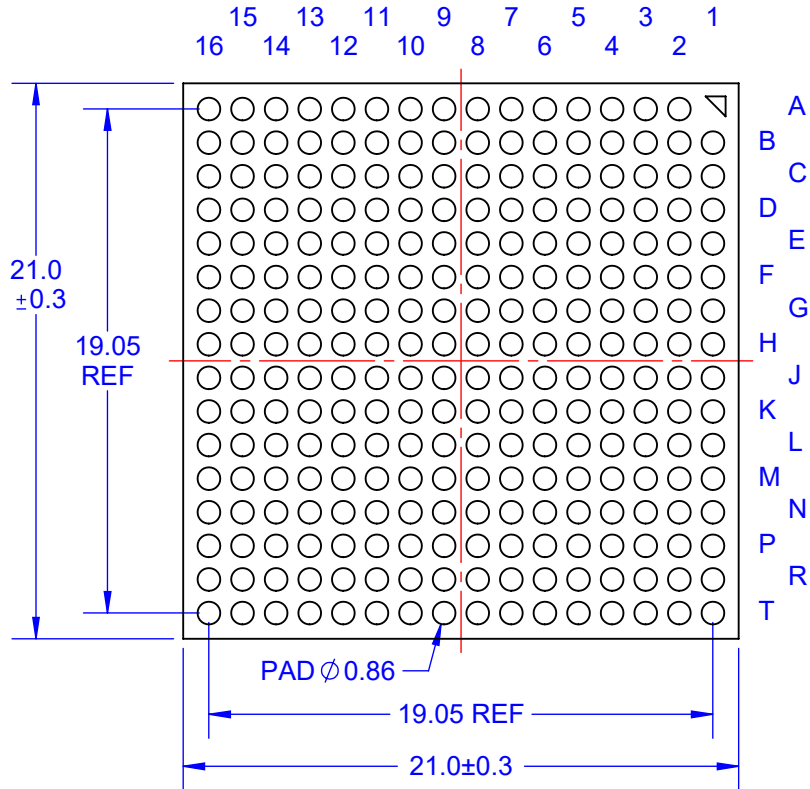

Pb90/Sn10
WIRE COLUMN

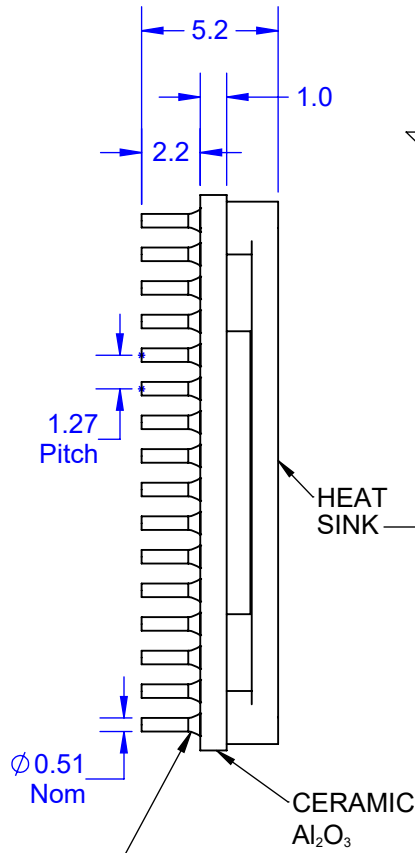

TOP VIEW

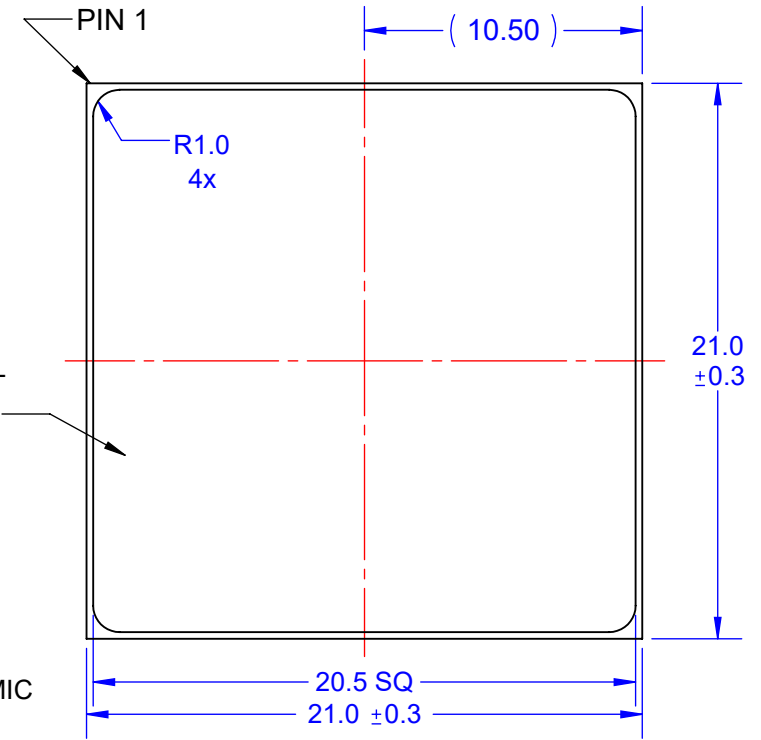

Notes: (Unless Otherwise Specified)

- 1) DIMENSION ARE IN mm.
- 2) SHOWN WITH Pb90/Sn10 PLAIN COLUMNS.
- 3) 255 COLUMNS.
- 4) DIE SIZE 10.7 x 7.8 x 0.9 MM.
- 5) PART NUMBER CCGA255T1.27A-CN.

PART NUMBER OPTIONS

PART NUMBER	DUMMY DIE	SOLDER PIN	HEATSINK
CCGA255T1.27A-CN	YES	Pb90/Sn10	YES

APPROVALS	DATE	TopLine®			
DRAWN T. Au	6/20/2021				
ENG M. Hart	6/20/2021	TITLE CCGA255T1.27A-CN COLUMN GRID ARRAY			
MFG		SCALE 3.5:1	SIZE A	DRAWING NO. 160032	REV A
QA		DO NOT SCALE DRAWING			SHEET 2 OF 11
CUST					
REVISED					

BOTTOM VIEW

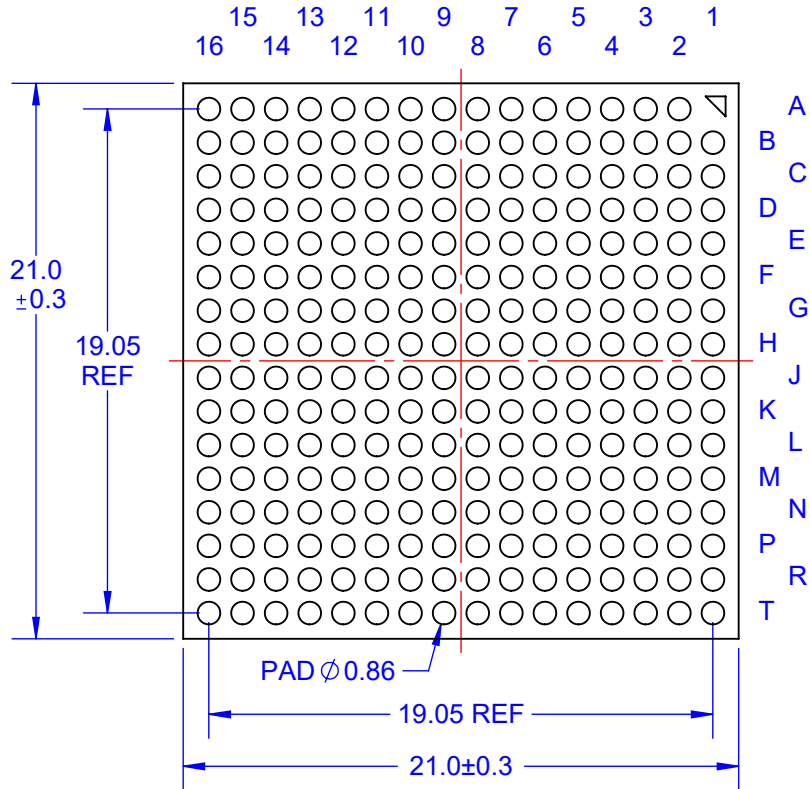

TOP VIEW

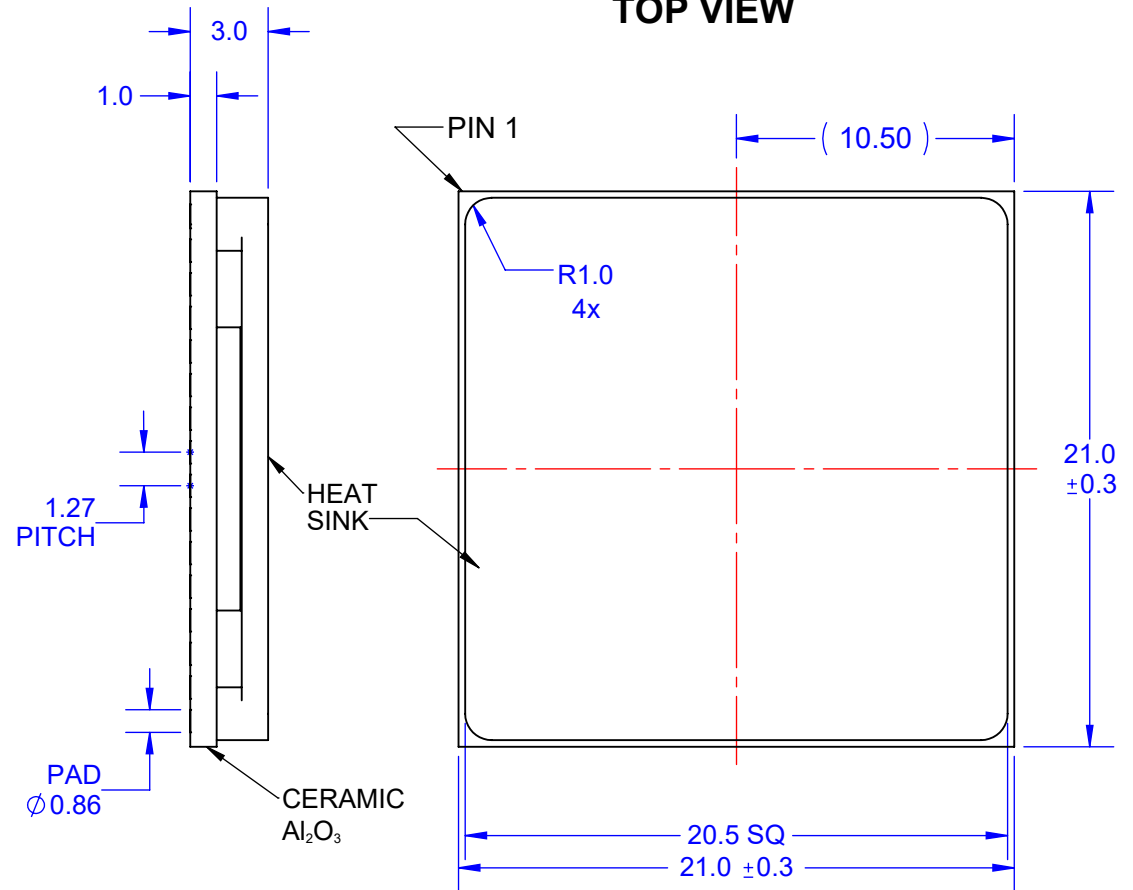

Notes: (Unless Otherwise Specified)

- 1) DIMENSION ARE IN mm.
- 2) SHOWN WITHOUT COLUMNS.
- 3) 255 PADS.
- 4) DIE SIZE 10.7 x 7.8 x 0.9 MM.
- 5) PART NUMBER CLGA255T1.27-CN.

PART NUMBER OPTIONS

PART NUMBER	DUMMY DIE	SOLDER PIN	HEATSINK
CLGA255T1.27-CN	YES	NO	YES

APPROVALS	DATE	TopLine®			
DRAWN T. Au	6/20/2021				
ENG M. Hart	6/20/2021	TITLE CCGA255T1.27-CN COLUMN GRID ARRAY			
MFG		SCALE 3.5:1	SIZE A	DRAWING NO. 160032	REV A
QA		DO NOT SCALE DRAWING			SHEET 3 OF 11
CUST					
REVISED					

SOLDER PIN Pb80/Sn20

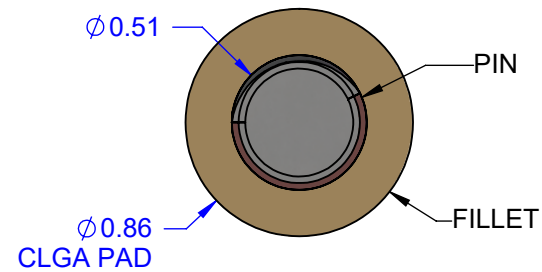
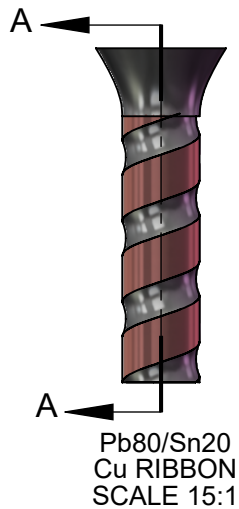
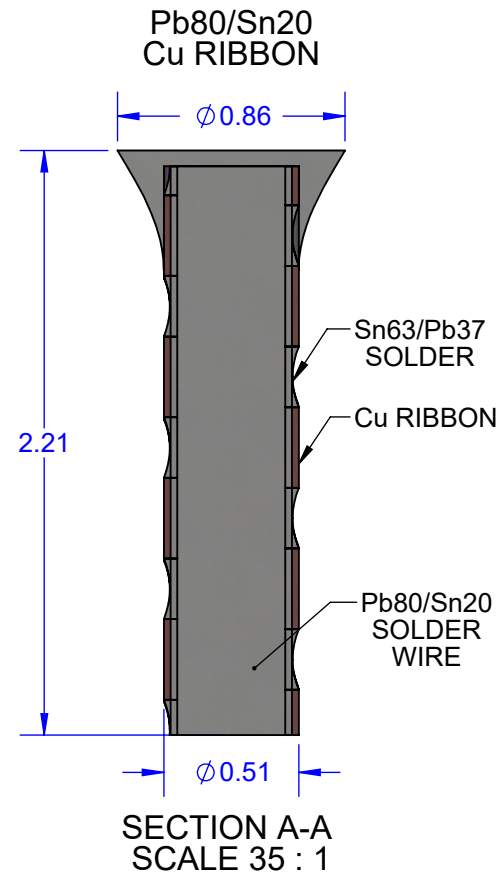
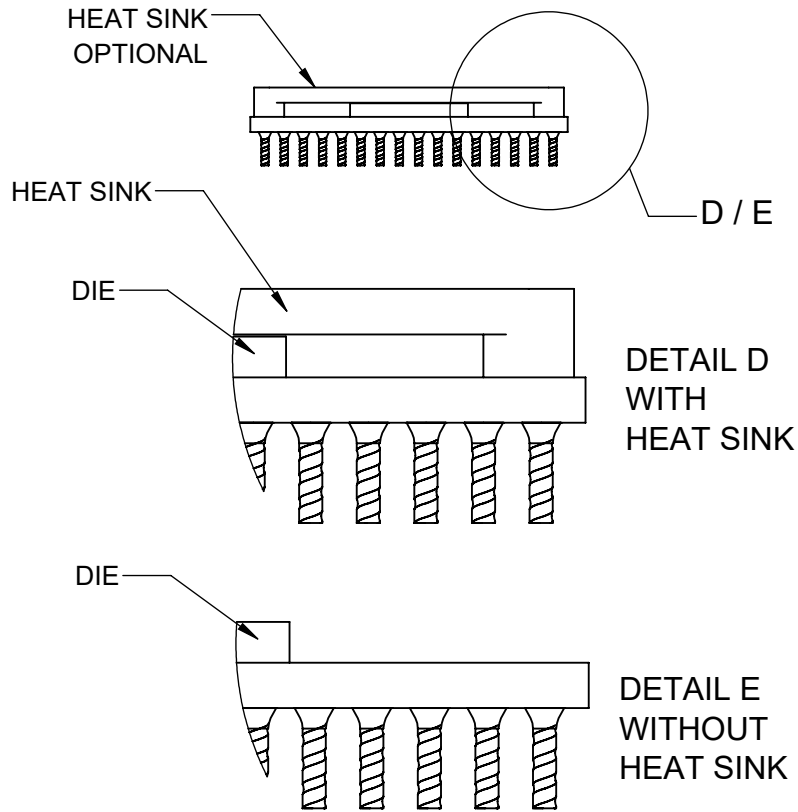

TopLine®			
TITLE CCGA255T1.27-CN COLUMN GRID ARRAY			
SCALE 1.75:1	SIZE A	DRAWING NO. 160032	REV A
DO NOT SCALE DRAWING			SHEET 4 OF 11

SOLDER PIN Pb90/Sn10

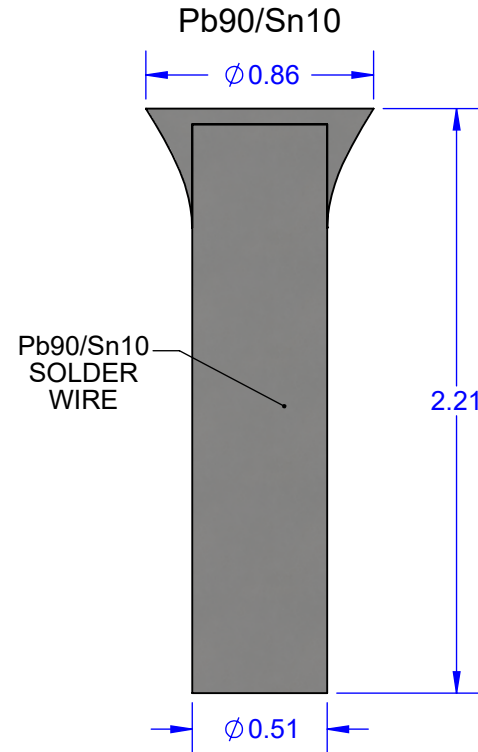
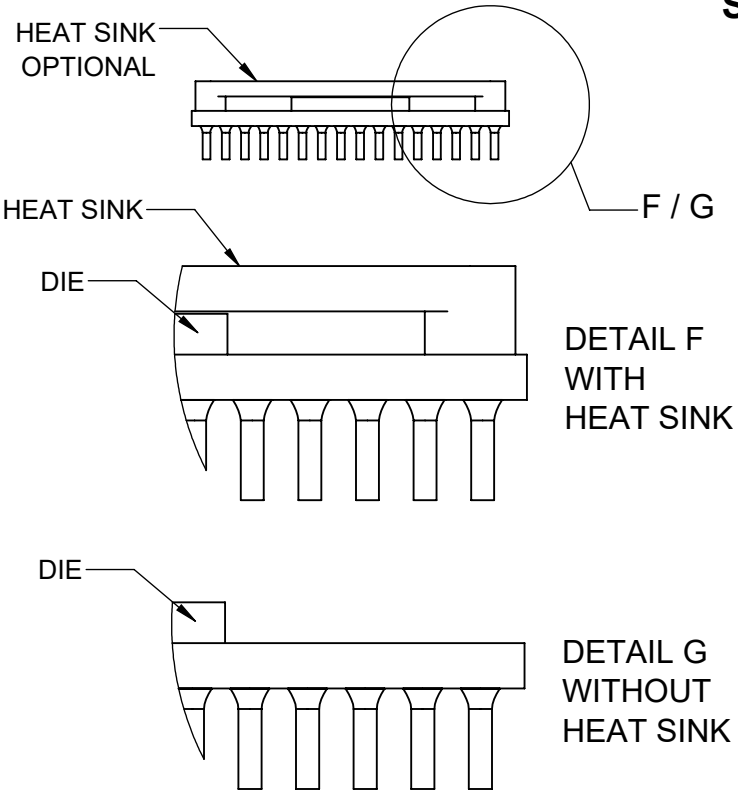

SECTION C-C
SCALE 35 : 1

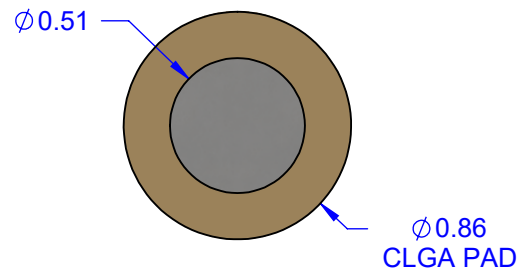
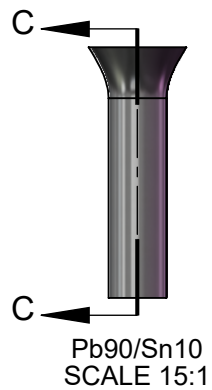

TopLine®			
TITLE CCGA255T1.27-CN COLUMN GRID ARRAY			
SCALE 1.75:1	SIZE A	DRAWING NO. 160032	REV A
DO NOT SCALE DRAWING			SHEET 5 OF 11

PAD PATTERN

COLUMN VIEW

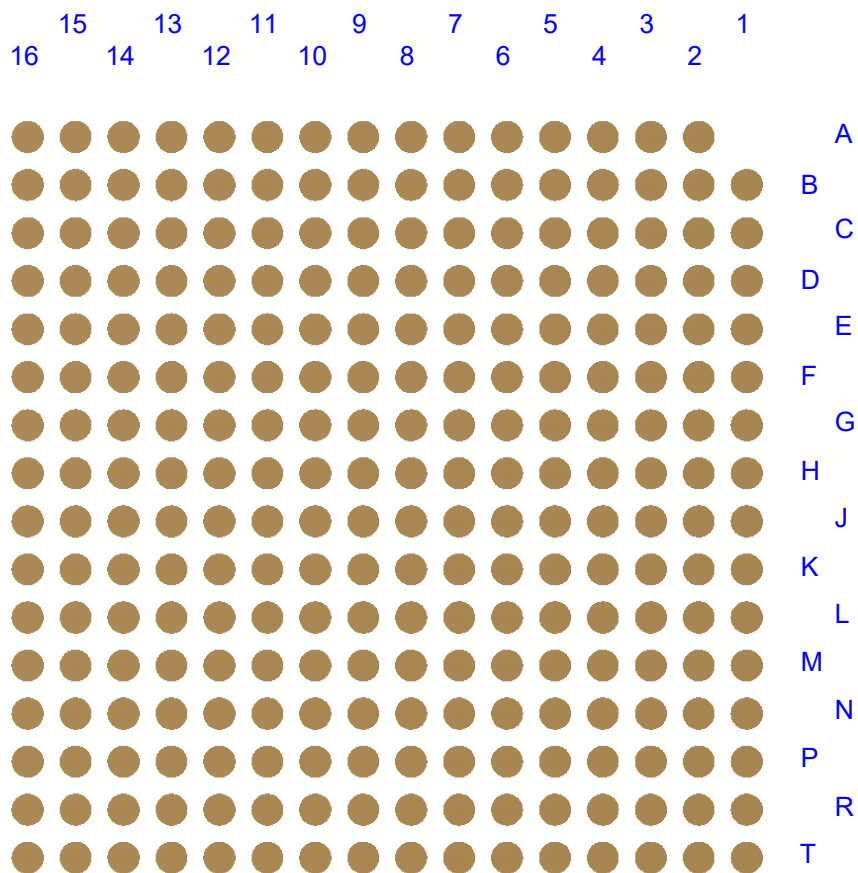

BOTTOM X-RAY VIEWED FROM TOP

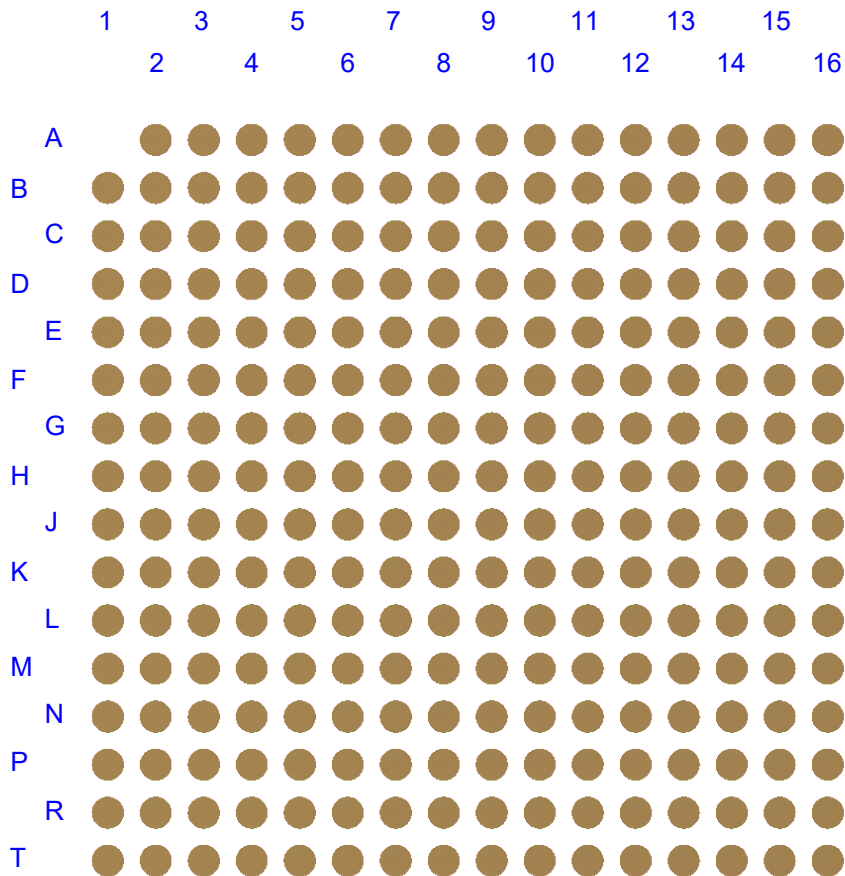

TopLine®

TITLE CCGA255T1.27-CN
COLUMN GRID ARRAY

SCALE 2.75:1	SIZE A	DRAWING NO. 160032	REV A
-----------------	-----------	-----------------------	----------

DO NOT SCALE DRAWING

SHEET 6 OF 11

**MODEL
WITH HEAT SINK
Pb80/Sn20**

TOP

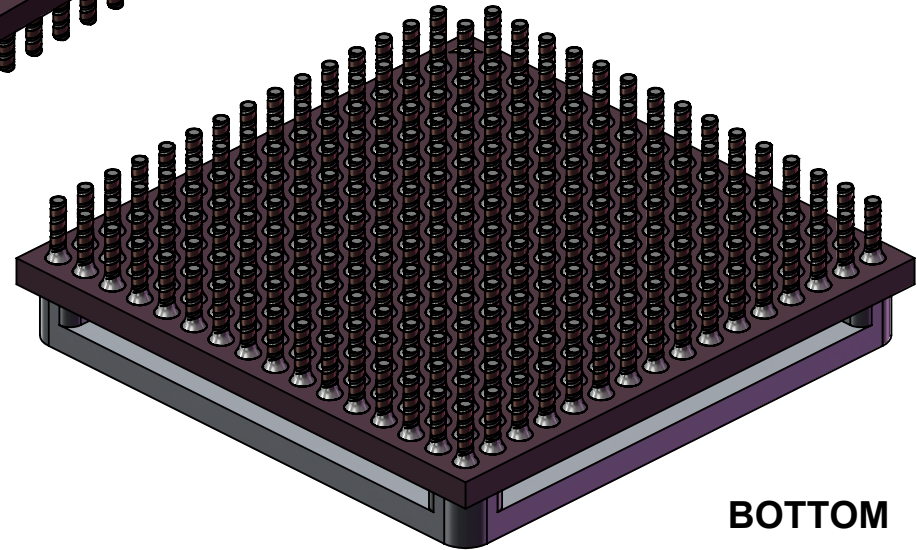
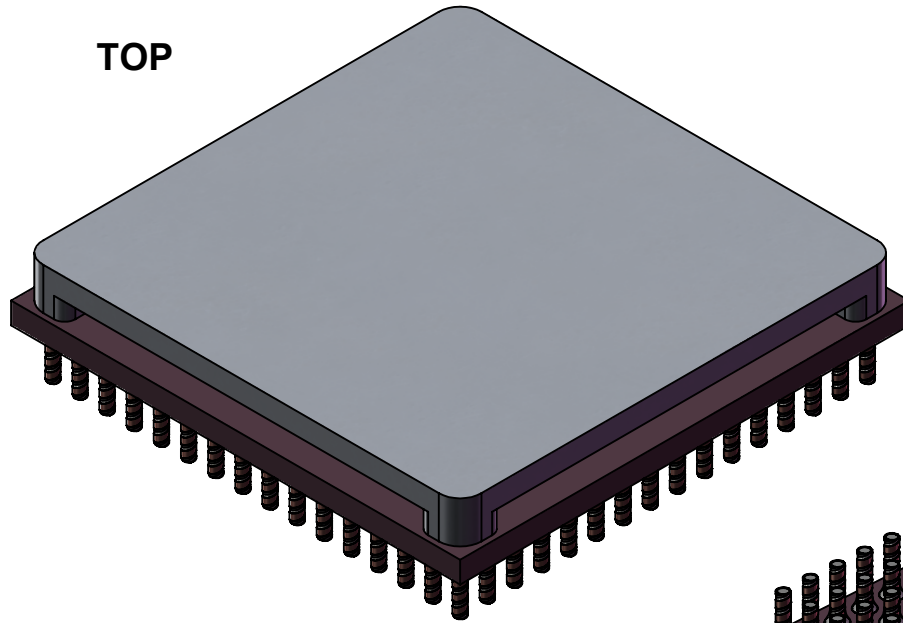

BOTTOM

TopLine®

TITLE CCGA255T1.27-CN
COLUMN GRID ARRAY

SCALE 2.75:1	SIZE A	DRAWING NO. 160032	REV A
-----------------	-----------	-----------------------	----------

DO NOT SCALE DRAWING

SHEET 7 OF 11

**MODEL
WITH HEAT SINK
Pb90/Sn10**

TOP

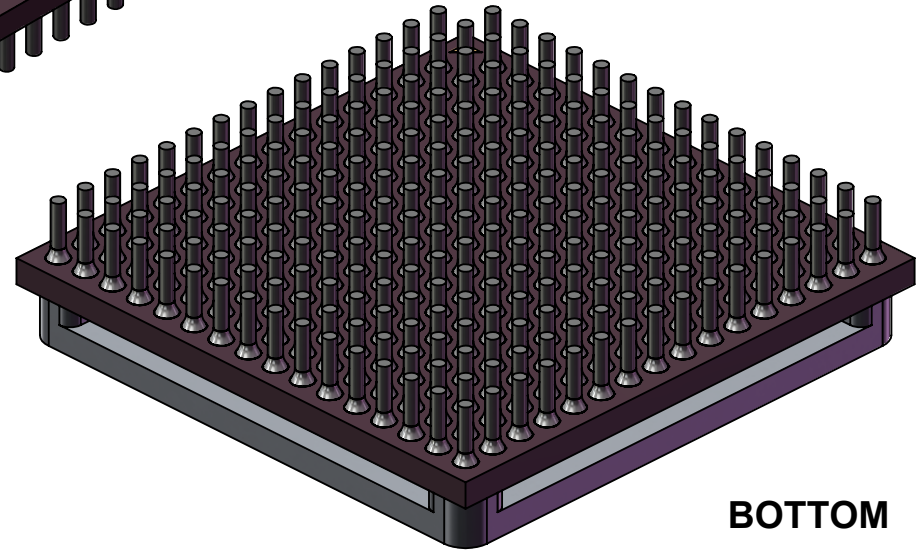
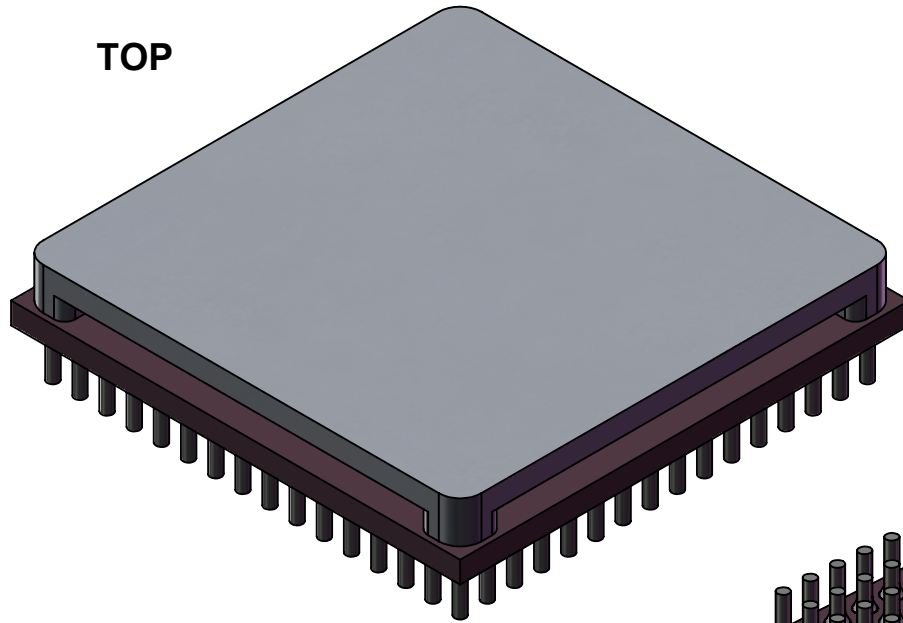

BOTTOM

TopLine®

TITLE CCGA255T1.27-CN
COLUMN GRID ARRAY

SCALE 2.75:1	SIZE A	DRAWING NO. 160032	REV A
-----------------	-----------	-----------------------	----------

DO NOT SCALE DRAWING

SHEET 8 OF 11

OPTIONAL HEAT SINK

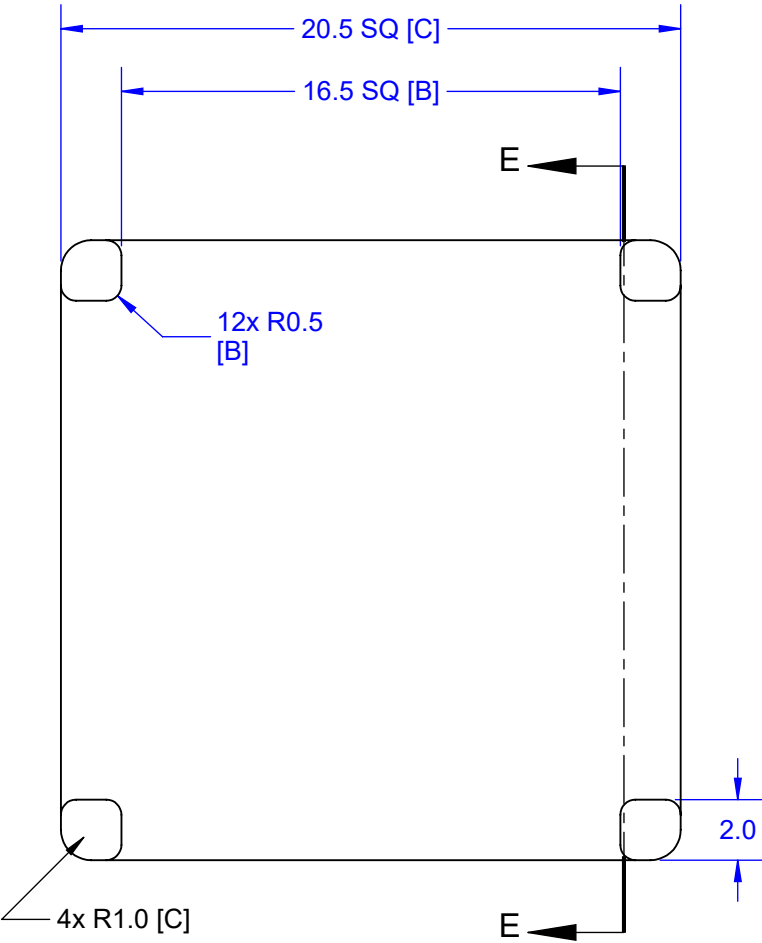

SECTION E-E
SCALE 4 : 1

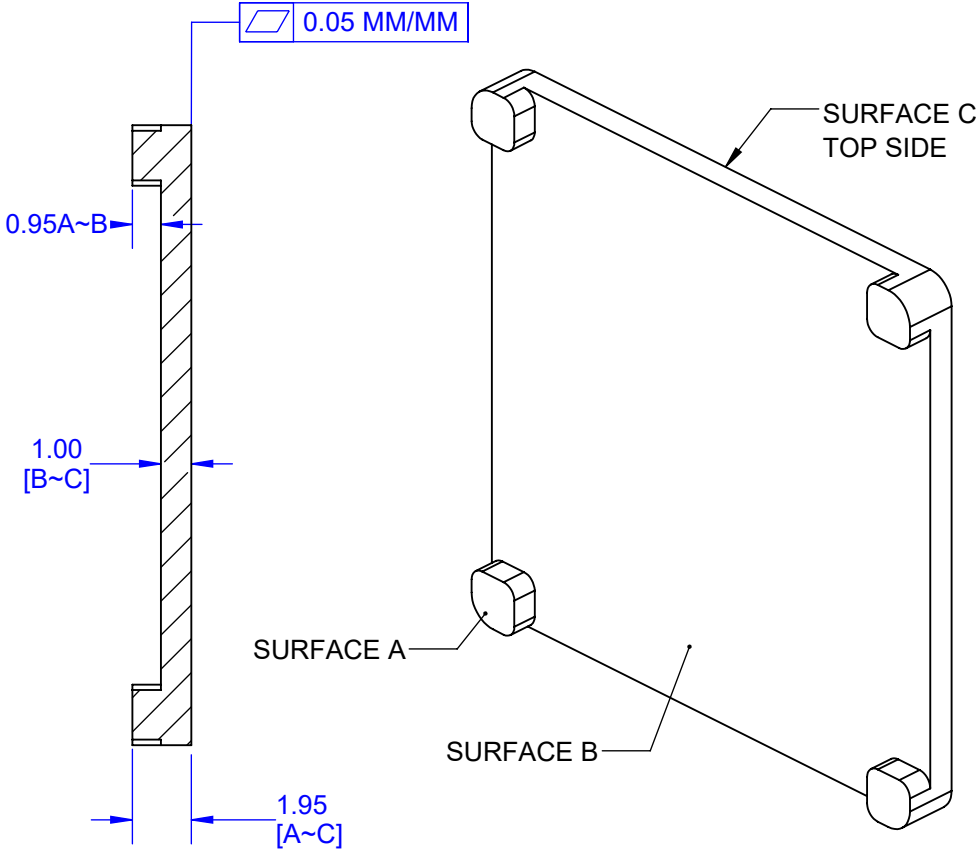

- 1. DIMENSION MM (UNLESS OTHERWISE STATED).
- 2. MATERIAL AISiC-8.
- 3. TOLERANCE ± 0.127 mm.
- 4. PLATING: ELECTROLESS NICKEL 4~8 μ m.

APPROVALS	DATE	TopLine®			
DRAWN T. Au	6/20/2021				
ENG M. Hart	6/20/2021	TITLE CN-CAP21A HEAT SPREADER			
MFG		SCALE 4:1	SIZE A	DRAWING NO. 111210	REV A
QA					
CUST		DO NOT SCALE DRAWING			SHEET 9 OF 11
REVISED					

**MODEL
OPTIONAL HEAT SINK**

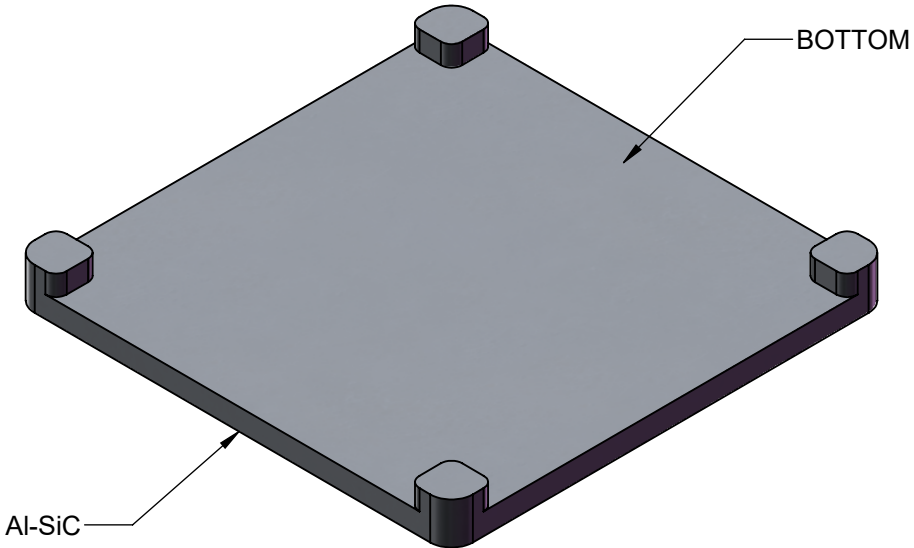
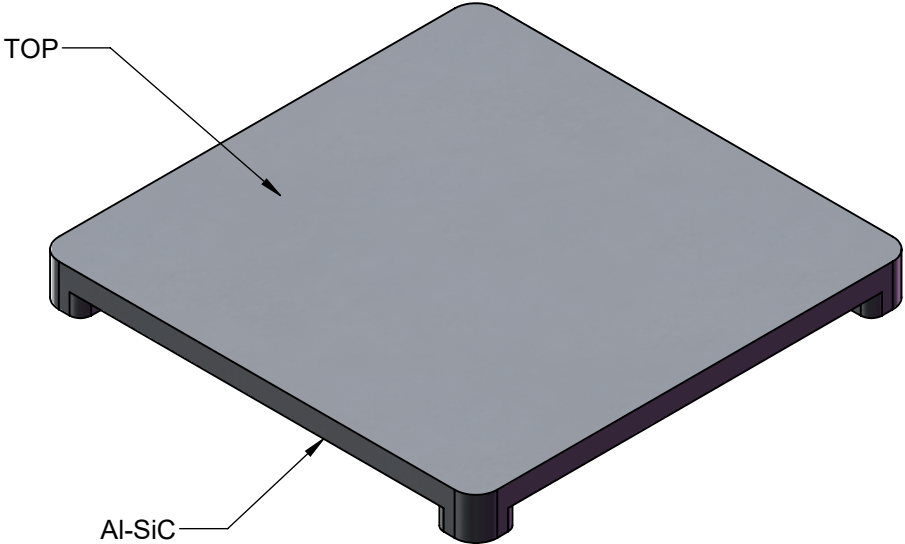

TopLine[®]

TITLE CN-CAP21A
HEAT SPREADER

SCALE 4:1	SIZE A	DRAWING NO. 111210	REV A
--------------	-----------	-----------------------	----------

DO NOT SCALE DRAWING SHEET 10 OF 11

EXPLODED VIEW CCGA TRAY BOX SYSTEM 1.27MM PITCH

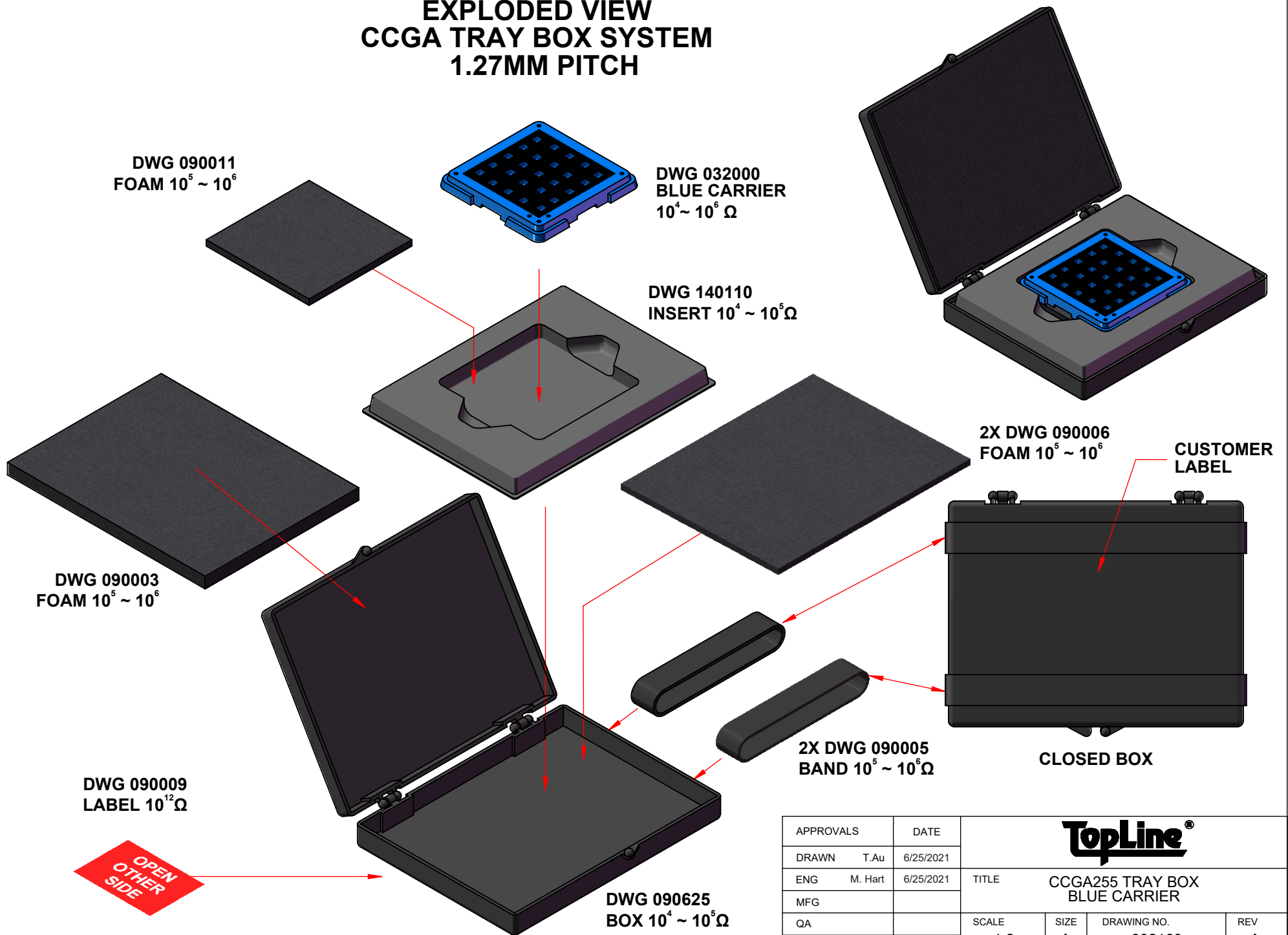

APPROVALS	DATE	TopLine®			
DRAWN T. Au	6/25/2021				
ENG M. Hart	6/25/2021	TITLE CCGA255 TRAY BOX BLUE CARRIER			
MFG		SCALE	SIZE	DRAWING NO.	REV
QA		1:2	A	932169	A
CUST		DO NOT SCALE DRAWING			SHEET 11 OF 11
REVISED					