

- NOTES:
1. TOLERANCE UNLESS OTHERWISE SPECIFIED TO BE ± 0.002 IN 3 PLACES DECIMAL.
 2. ALUMINIZATION COVERAGE TO BE 0.700 ± 0.020 SQUARE, PURITY TO BE 99.9%
 3. SOLDER GLASS ON BASE AND WINDOW FRAME TO BE CORNING 3583.
 4. CERAMIC MATERIAL TO BE BLACK ALUMINA 90%.
 5. LEAD FRAME MATERIAL TO BE ALLOY 42 (0.005 ± 0.0005 THICKNESS).
 6. DOUBLE TARGET MARK ON PIN 1, SINGLE TARGET MARKS ON PIN 37, 73 AND 109.
 7. MAXIMUM PACKAGE ENVELOPE INCLUDES CERAMIC MISMATCH, TOLERANCE AND GLASS SQUEEZOUT.
 8. UNPLATED ALLOY 42 LEAD FRAME.

APPROVALS	DATE	TopLine®			
DRAWN T. Au	09/28/15				
ENG M. Hart	09/28/15	TITLE CERQUAD144F25-NU350 UNPLATED LEAD FRAME			
MFG		SCALE 2.5:1	SIZE A	DRAWING NO. 181689	REV A
QA		DO NOT SCALE DRAWING			SHEET 1 OF 3
CUST					
REVISED					

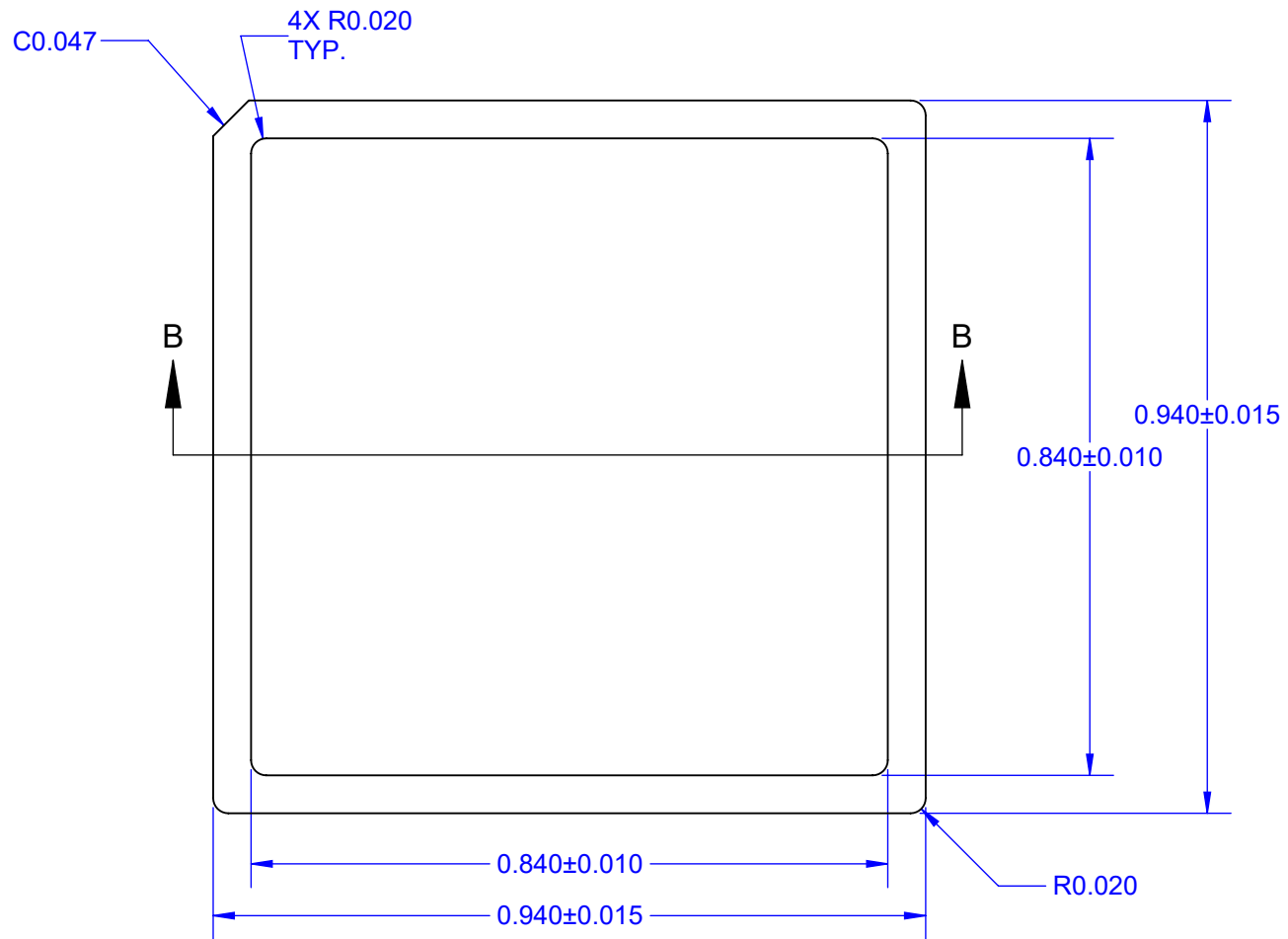

SECTION B-B

BLACK CERAMIC (90-96% Al₂O₃)

TopLine[®]			
TITLE		C-LID24E-BLACK CERAMIC LID	
SCALE	SIZE	DRAWING NO.	REV
4:1	A	181689	A
DO NOT SCALE DRAWING			SHEET 2 OF 3

MODEL

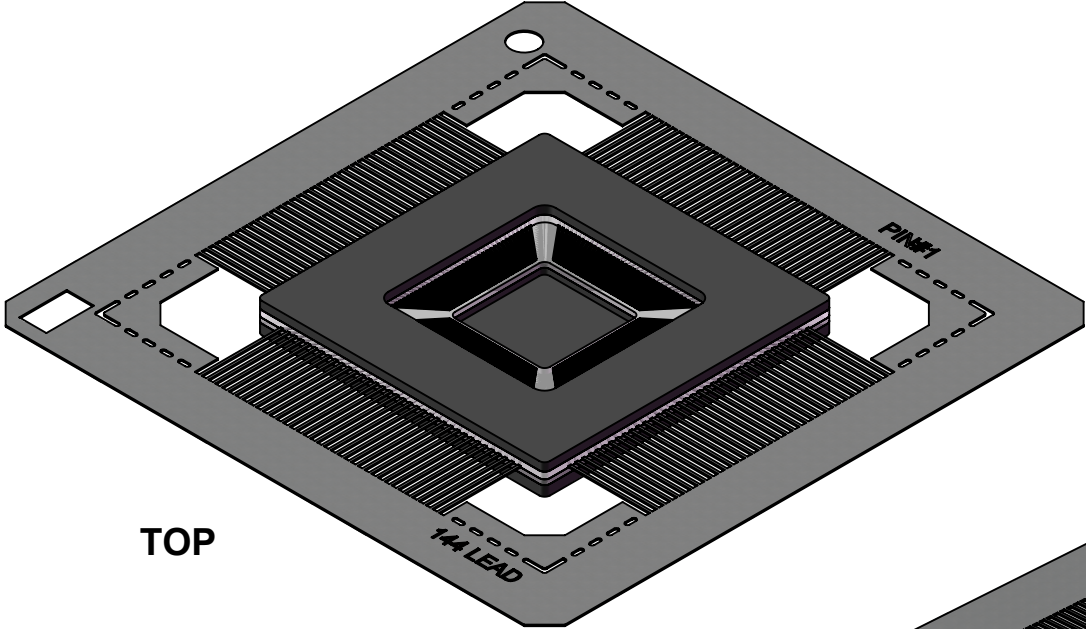

TOP

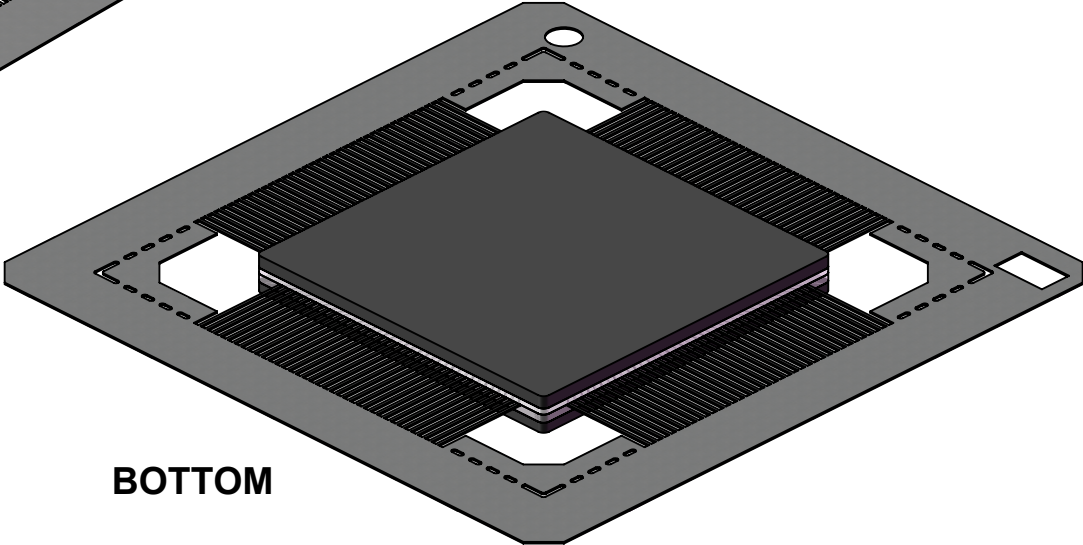

BOTTOM

TopLine®			
TITLE CERQUAD144F25-NU350 UNPLATED LEAD FRAME			
SCALE 2:1	SIZE A	DRAWING NO. 181689	REV A
DO NOT SCALE DRAWING			SHEET 3 OF 3