

- Notes: (Unless Otherwise Specified).
- 1) DIMENSIONS: MM [INCH].
 - 2) KOVAR FLAT LEADS ON CERAMIC Alumina 90 BLACK BODY.
 - 3) ALL EXPOSED METAL GOLD PLATED (Au).
 - 4) PLATING Ni 50~350 micro-inch Au 60 micro-inch MIN.
 - 5) WEIGHT OF PACKAGE 8 gram AFTER EXCISING TIE-BAR [6]

APPROVALS	DATE	TopLine®			
DRAWN T. Au	08/09/15				
ENG M. Hart	08/09/15	TITLE CERQUAD208F19.7-DE 208 PIN - 0.5mm PITCH			
MFG		SCALE	SIZE	DRAWING NO.	REV
QA		3:2	A	133208	A
CUST		DO NOT SCALE DRAWING			SHEET 1 OF 8
REVISED					

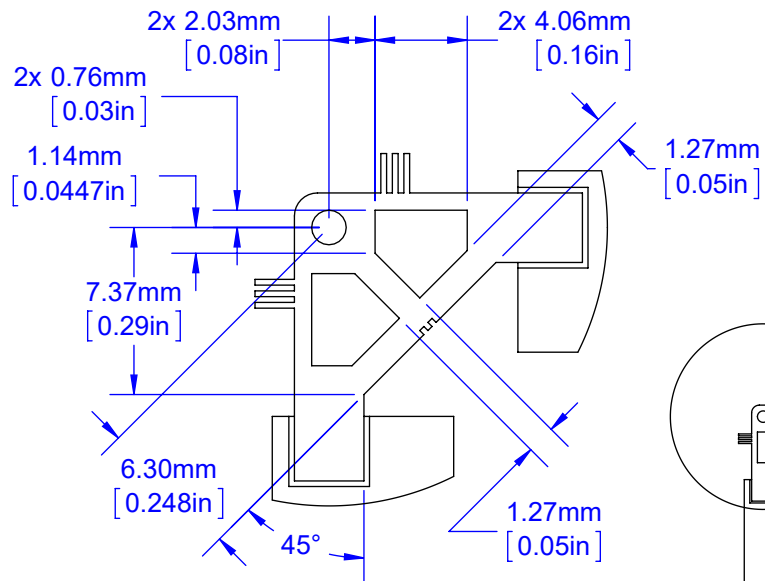

DETAIL B
SCALE 3 : 1

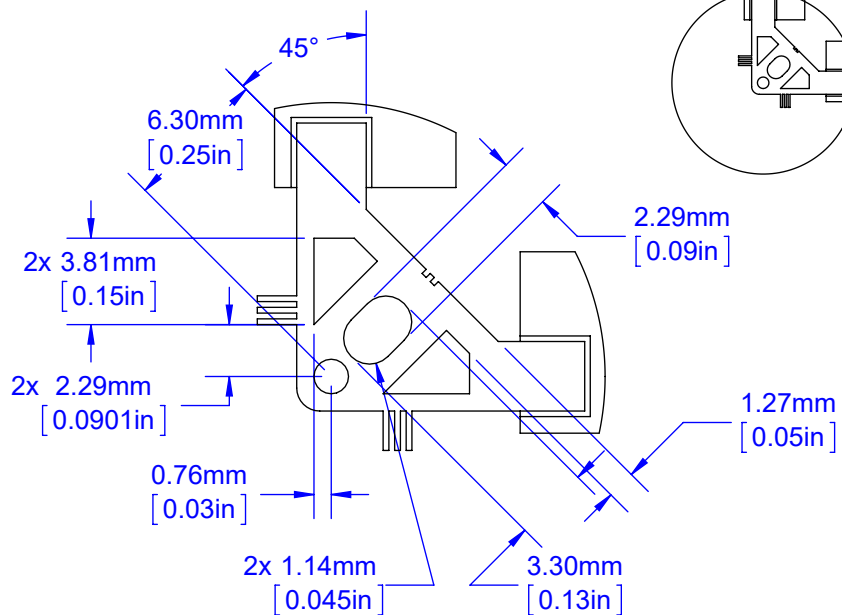

DETAIL D
SCALE 3 : 1

TIE BAR

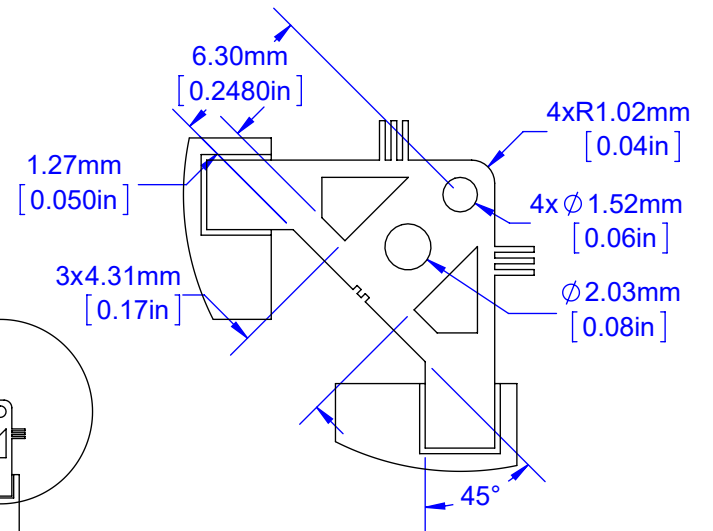
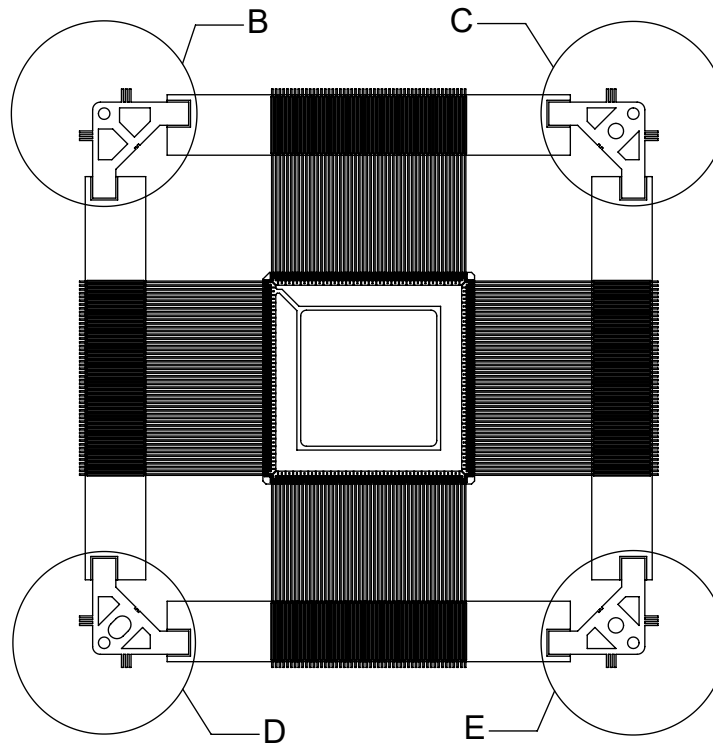

DETAIL C
SCALE 3 : 1

DETAIL E
SCALE 3 : 1

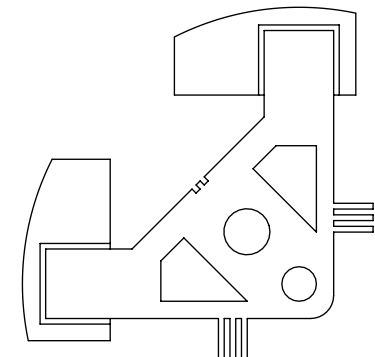

TopLine®			
TITLE		CERQUAD208F19.7-DE 208 PIN - 0.5mm PITCH	
SCALE	SIZE	DRAWING NO.	REV
1:1	A	133208	A
DO NOT SCALE DRAWING			SHEET 2 OF 8

TOP VIEW

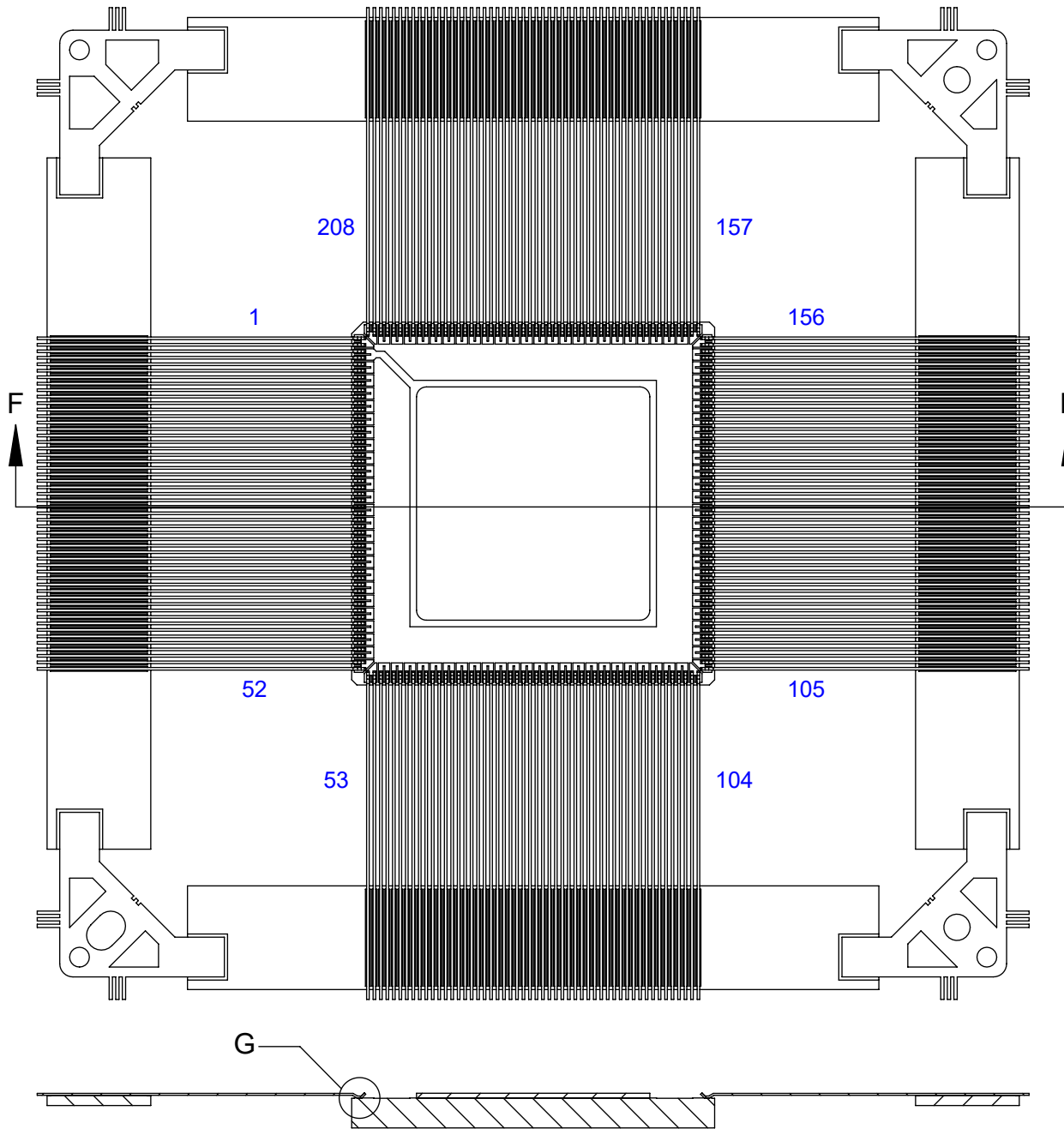

SECTION F-F

CERQUAD LEAD FRAME

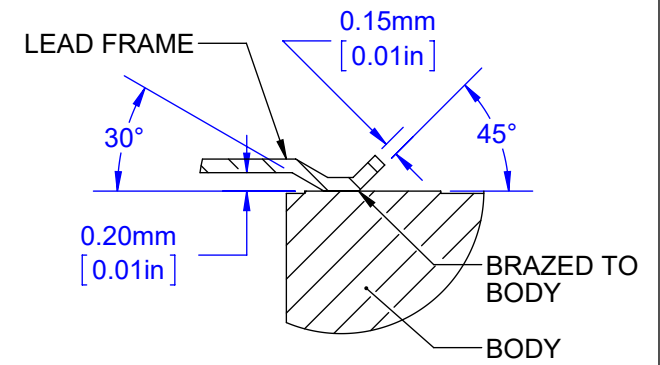

DETAIL G
SCALE 12 : 1

TopLine®			
TITLE CERQUAD208F19.7-DE 208 PIN - 0.5mm PITCH			
SCALE 2:1	SIZE A	DRAWING NO. 133208	REV A
DO NOT SCALE DRAWING			SHEET 3 OF 8

**CERQUAD208
CERAMIC BODY
TOP VIEW**

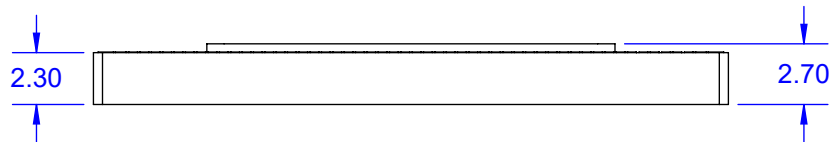
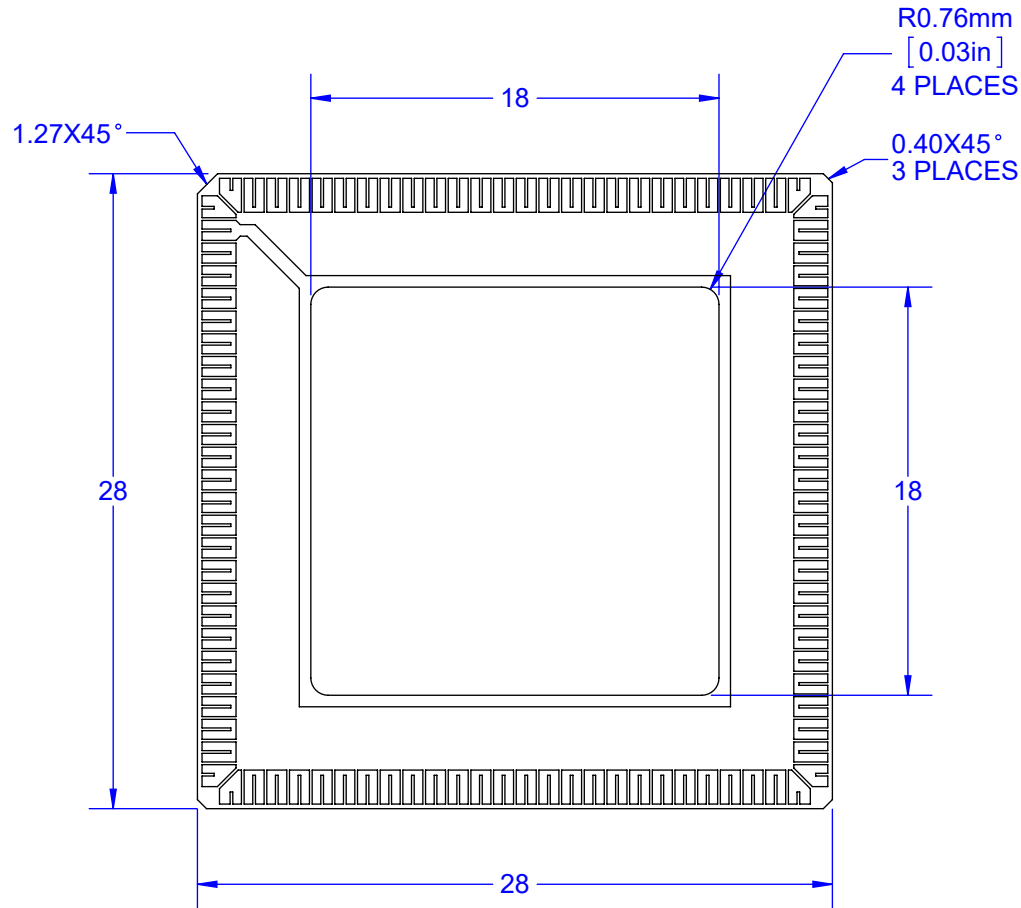

TopLine®			
TITLE CERQUAD208F19.7-DE 208 PIN - 0.5mm PITCH			
SCALE 2:1	SIZE A	DRAWING NO. 133208	REV A
DO NOT SCALE DRAWING		SHEET 4 OF 8	

BOTTOM VIEW

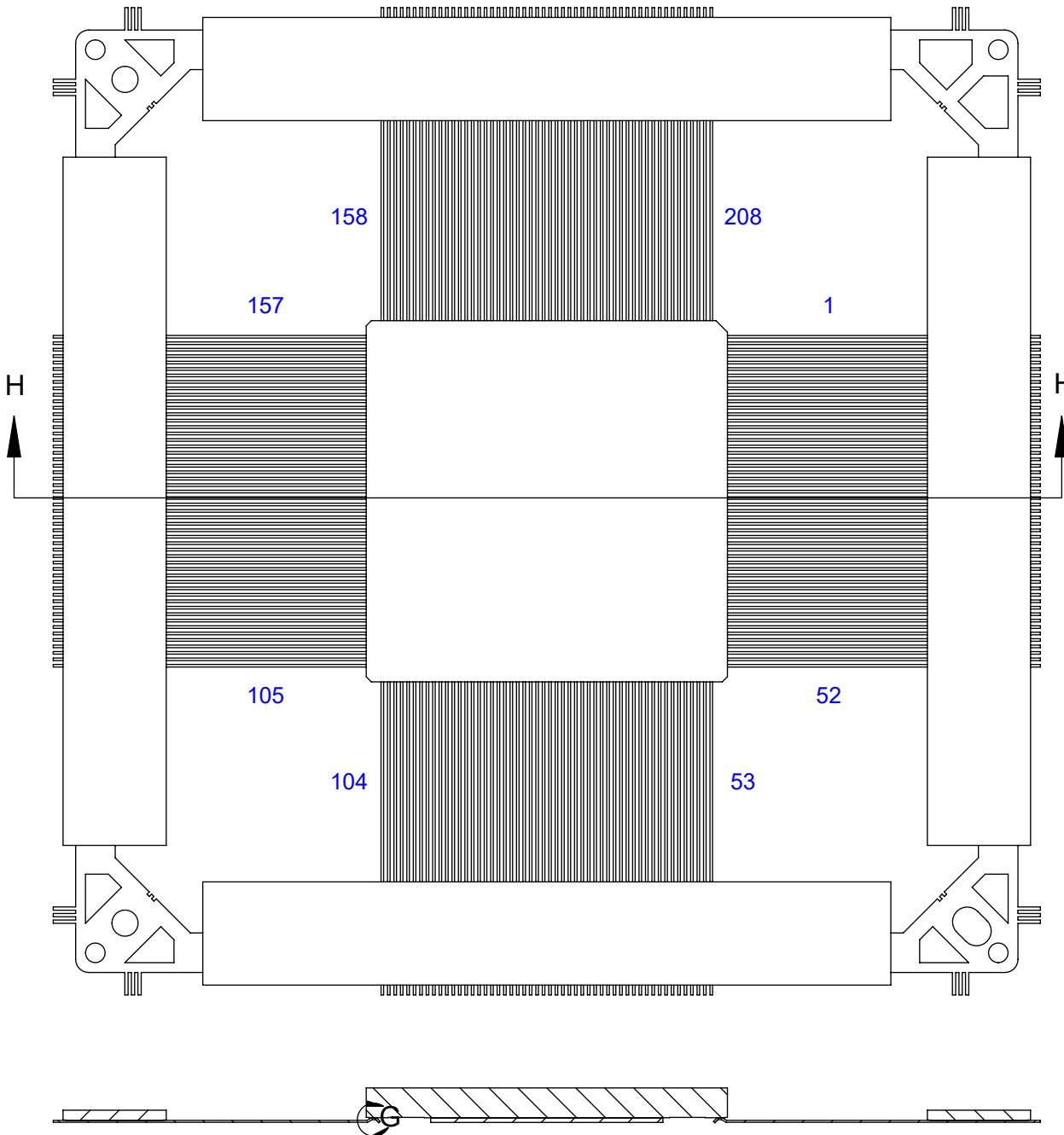

SECTION H-H

CERQUAD LEAD FRAME

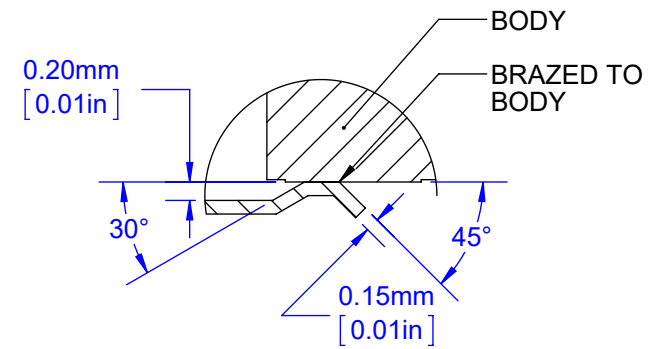

DETAIL G
SCALE 12 : 1

TopLine®			
TITLE CERQUAD208F19.7-DE 208 PIN - 0.5mm PITCH			
SCALE 2:1	SIZE A	DRAWING NO. 133208	REV A
DO NOT SCALE DRAWING			SHEET 5 OF 8

CERQUAD208
MODEL
TOP

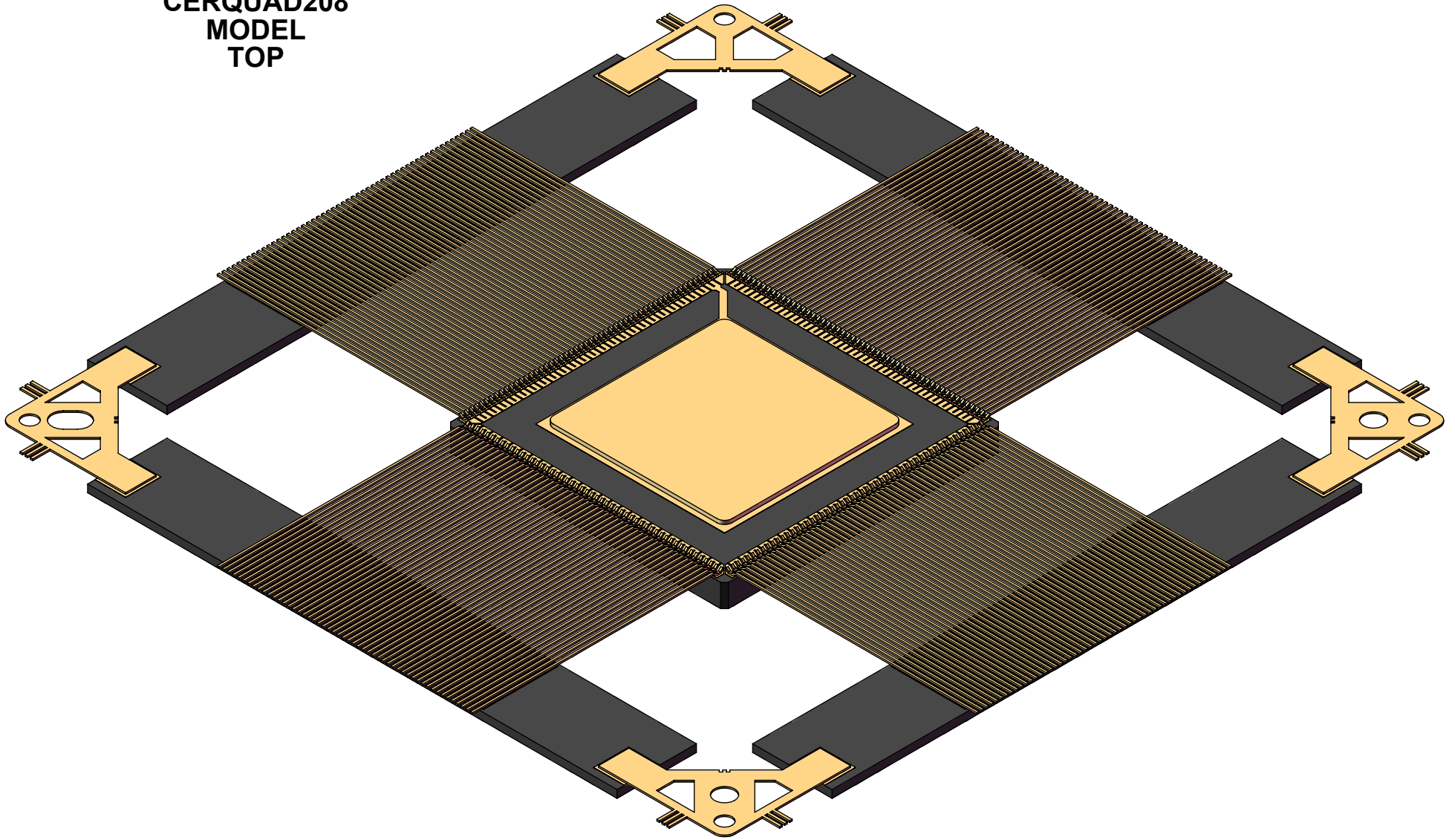

TopLine[®]

TITLE CERQUAD208F19.7-DE
208 PIN - 0.5mm PITCH

SCALE 2.5:1	SIZE A	DRAWING NO. 133208	REV A
----------------	-----------	-----------------------	----------

DO NOT SCALE DRAWING

SHEET 6 OF 8

CERQUAD208
MODEL
BOTTOM

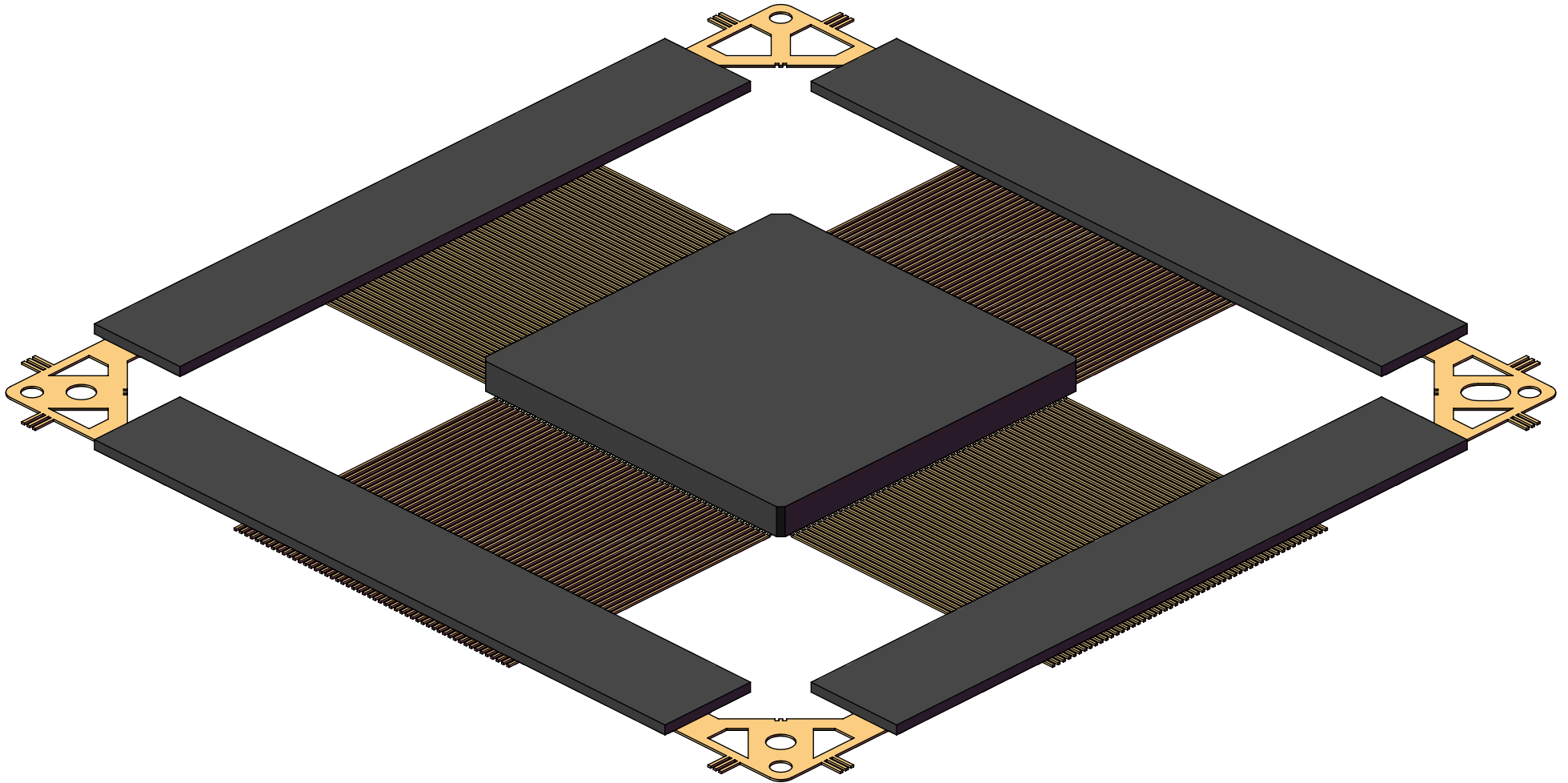

TopLine[®]

TITLE CERQUAD208F19.7-DE
208 PIN - 0.5mm PITCH

SCALE 2.5:1	SIZE A	DRAWING NO. 133208	REV A
----------------	-----------	-----------------------	----------

DO NOT SCALE DRAWING

SHEET 7 OF 8

DAISY CHAIN NET LIST

FROM	TO
1	2
3	4
5	6
7	8
9	10
11	12
13	14
15	16
17	18
19	20
21	22
23	24
25	26
27	28
29	30
31	32
33	34
35	36
37	38
39	40
41	42
43	44
45	46
47	48
49	50
51	52
53	54
55	56
57	58
59	60

FROM	TO
61	62
63	64
65	66
67	68
69	70
71	72
73	74
75	76
77	78
79	80
81	82
83	84
85	86
87	88
89	90
91	92
93	94
95	96
97	98
99	100
101	102
103	104
105	106
107	108
109	110
111	112
113	114
115	116
117	118
119	120

FROM	TO
121	122
123	124
125	126
127	128
129	130
131	132
133	134
135	136
137	138
139	140
141	142
143	144
145	146
147	148
149	150
151	152
153	154
155	156
157	158
159	160
161	162
163	164
165	166
167	168
169	170
171	172
173	174
175	176
177	178
179	180

FROM	TO
181	182
183	184
185	186
187	188
189	190
191	192
193	194
195	196
197	198
199	200
201	202
203	204
205	206
207	208

TopLine®			
TITLE CERQUAD208F19.7-DE 208 PIN - 0.5mm PITCH			
SCALE NONE	SIZE A	DRAWING NO. 133208	REV A
DO NOT SCALE DRAWING			SHEET 8 OF 8