

HCDJ9K

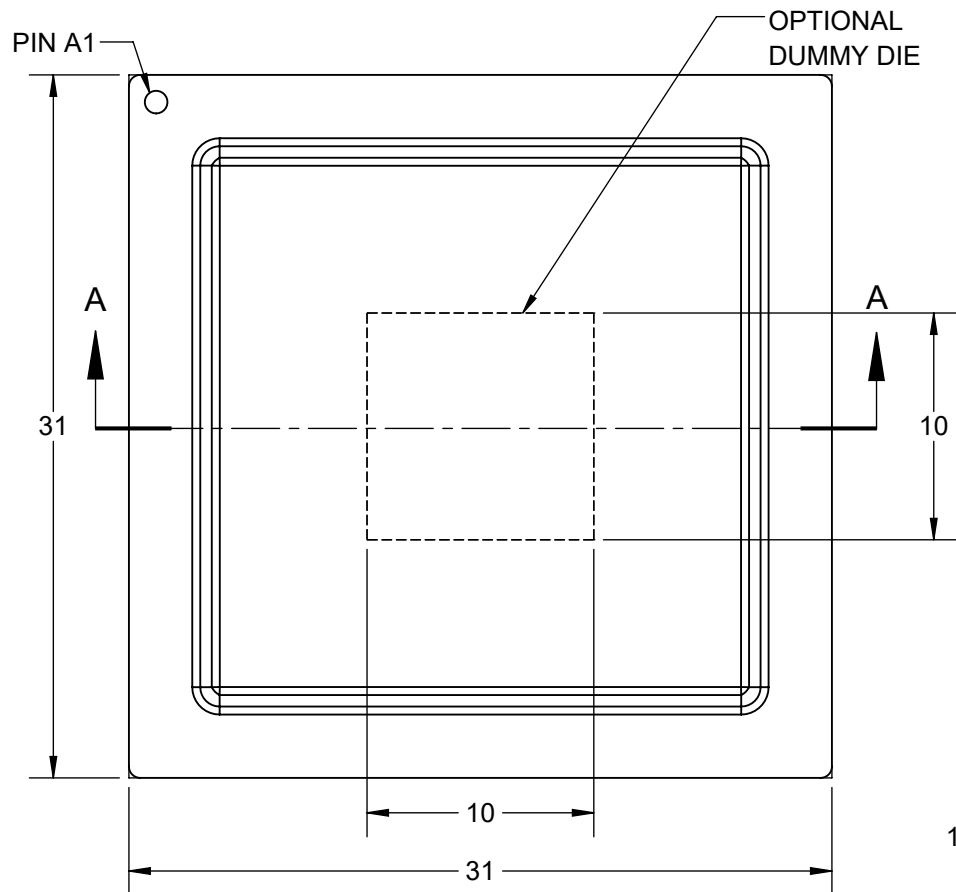

65 @J9K

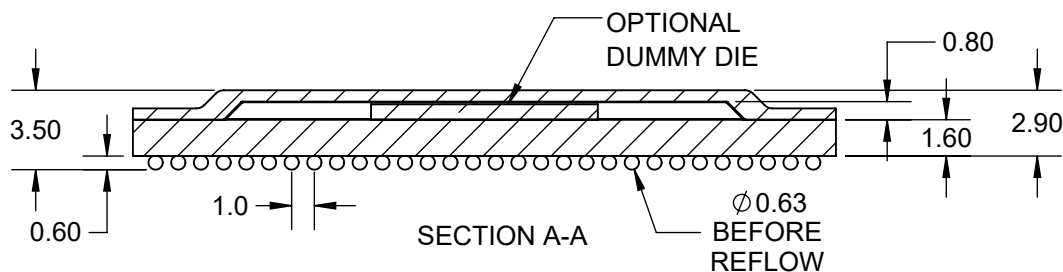
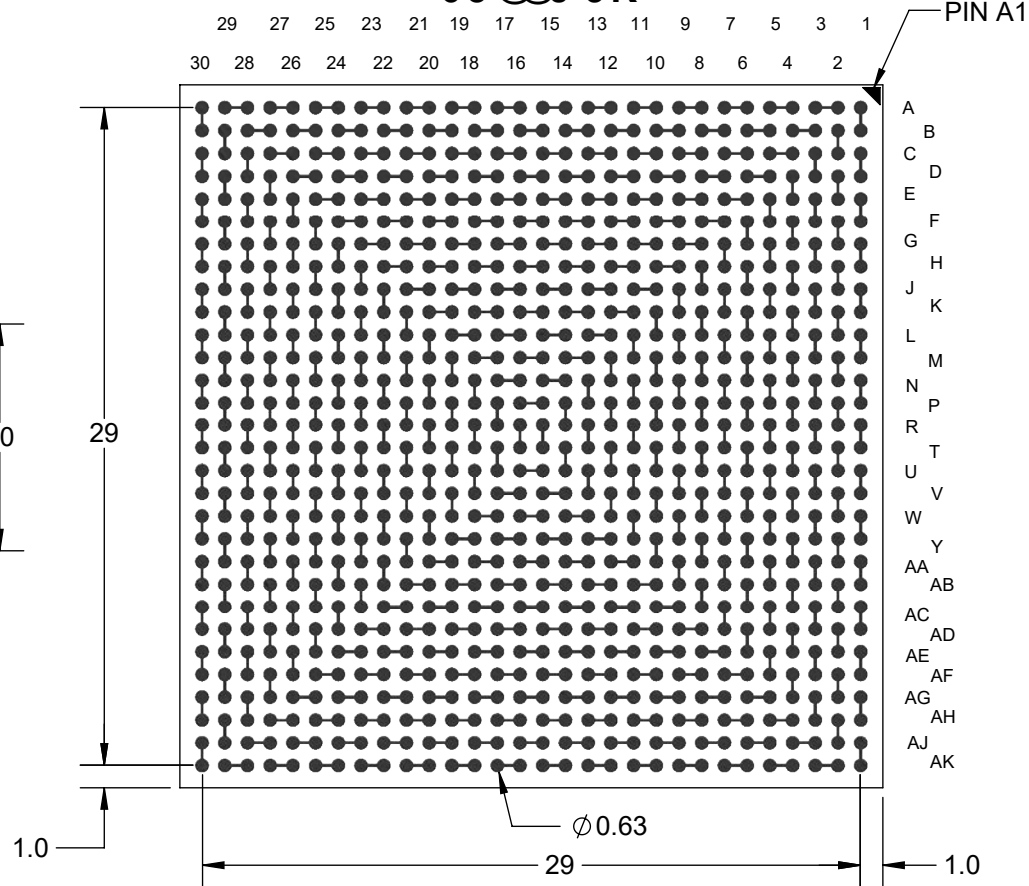

Notes: (Unless Otherwise Specified).

- 1) ALL DIMENSIONS ARE IN MM.
- 2) SOLDER BALL ALLOY: SEE PART NUMBER TABLE.
- 3) BALL DIAMETER (BEFORE REFLOW): 0.63mm (25 MIL).
- 4) SOLDER MASK DEFINED PAD OPENING: 0.50mm (19.7 MIL).
- 5) PAD Cu DIAMETER: 0.63mm (25 MIL).
- 6) SUBSTRATE MATERIAL: BT (ALTERNATIVE FR4).
- 7) DUMMY DIE IS OPTIONAL.
- 8) DAISY CHAIN PATTERN (SEE PAGE 2).
- 9) MSL-3 RECOMMENDED BAKING 24 HOURS @ 125°C TO REMOVE MOISTURE PRIOR SOLDERING TO PC BOARD.

D5FHBI A69FH56 @				
D5FHBI A69F	65 @25 @CM	DVI: F99	Fc < G	GJ'89
SBGA900T1.0C-DC309D	Sn96.5/Ag3.0/Cu0.5	YES	YES	YES
SBGA900T1.0-DC309D	Sn63/Pb37	NO	NO	YES

APPROVALS	DATE				
DRAWN T.Au	9/21/2020				
ENG M. Hart	9/21/2020	TITLE		SBGA900T1.0C-DC309D DAISY CHAIN DUMMY	
MFG		SCALE	SIZE	DRAWING NO.	REV
QA		3:1	A	513095	A
CUST		DO NOT SCALE DRAWING			SHEET 1 OF 9
REVISED					

65 @J-K

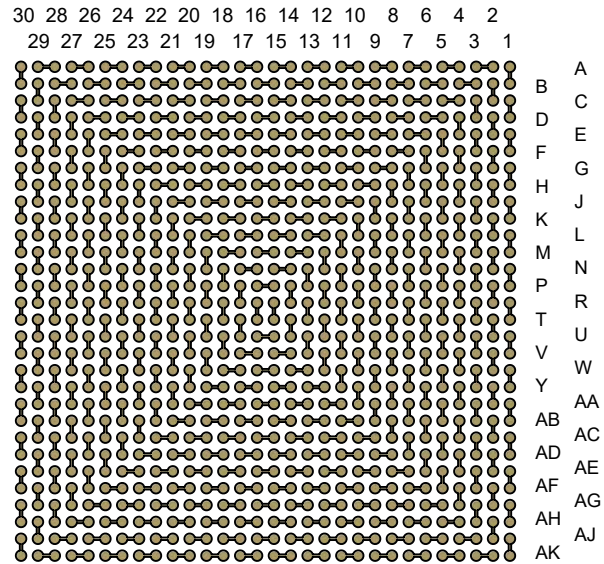

6 CHCA G-89 fHCD L!F5 MJ-K L

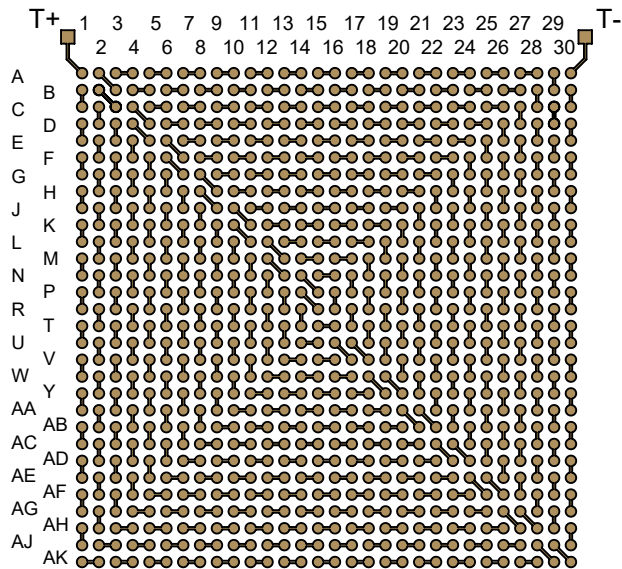
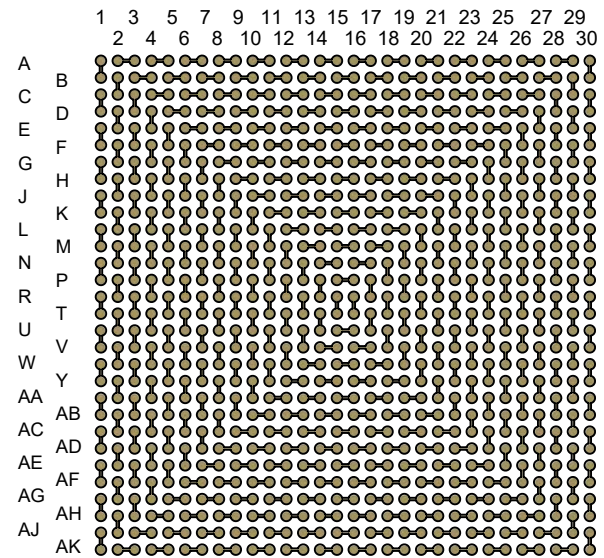

H9GH J9 <=7 @ 6 C5 F8

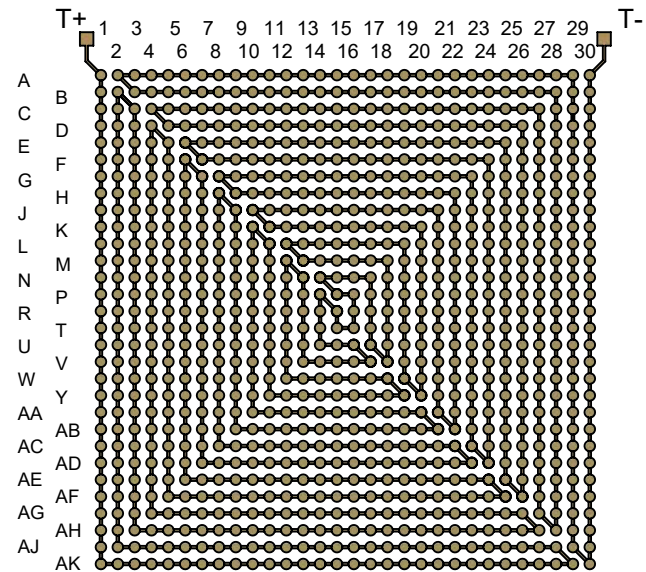

5 : H9F ACI BH-B;

Notes:

- 1) PCB BOARD DIMENSIONS ARE PRESENTED ONLY AS A GUIDELINE. DESIGNERS SHOULD USE THEIR OWN EXPERIENCE WHEN DESIGNING PCB.
- 2) PCB Cu BALL PAD DIAMETER 0.63mm [25 MIL].
- 3) PCB DAISY CHAIN TRACING LINE WIDTH 0.20mm [8 MIL].
- 4) SMD (SOLDER MASK DEFINED) PAD OPENING: 0.5mm [19.7 MIL].

TopLine®

TITLE		SBGA900T1.0C-DC309D DAISY CHAIN DUMMY	
SCALE	SIZE	DRAWING NO.	REV
3:1	A	513095	A
DO NOT SCALE DRAWING		SHEET 2 OF 9	

65 @@J→K

30 28 26 24 22 20 18 16 14 12 10 8 6 4 2
 29 27 25 23 21 19 17 15 13 11 9 7 5 3 1

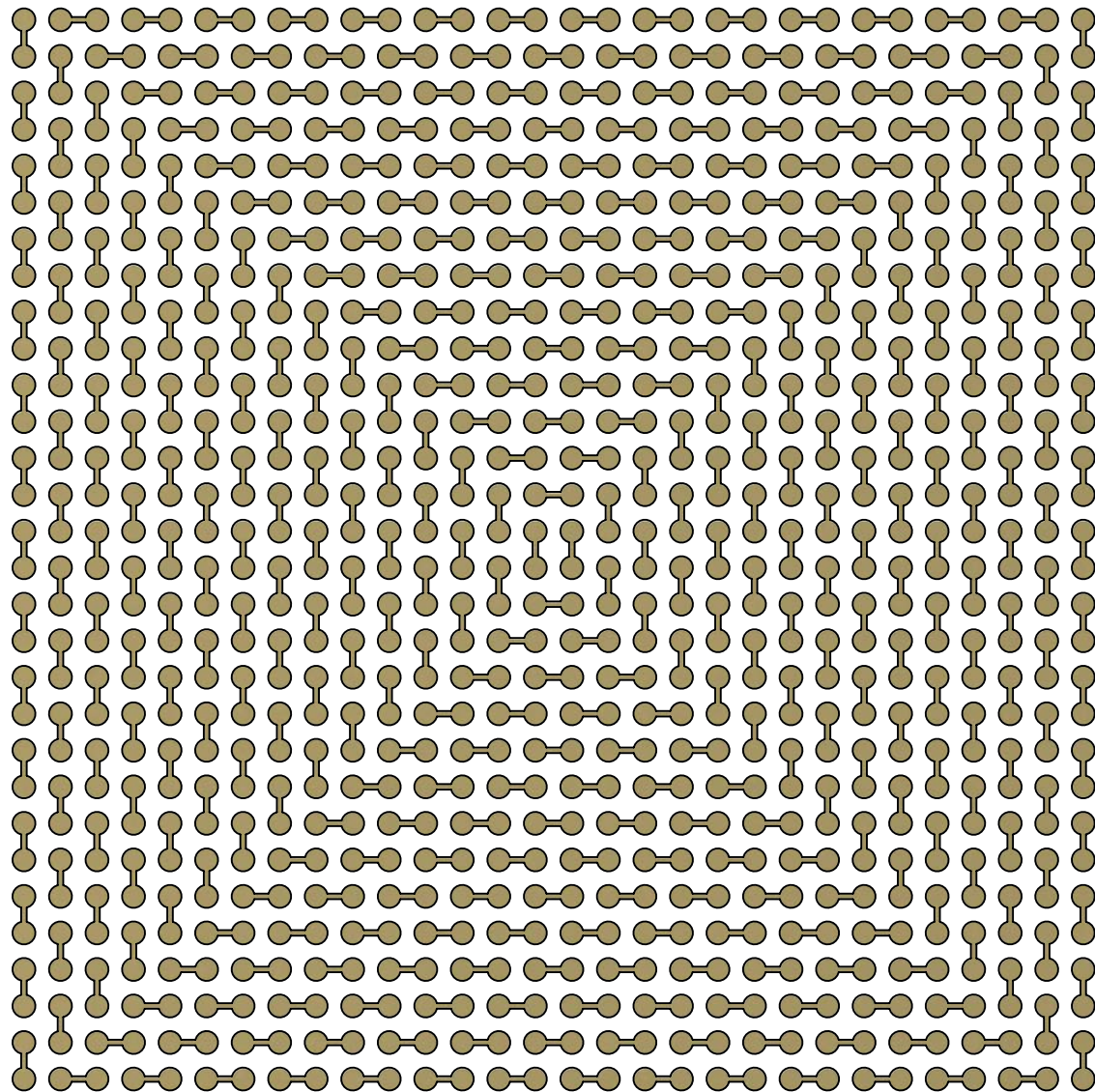

A
 B
 C
 D
 E
 F
 G
 H
 J
 K
 L
 M
 N
 P
 R
 T
 U
 V
 W
 Y
 AA
 AB
 AC
 AD
 AE
 AF
 AG
 AH
 AJ
 AK

TopLine®			
TITLE		SBGA900T1.0C-DC309D DAISY CHAIN DUMMY	
SCALE	SIZE	DRAWING NO.	REV
3:1	A	513095	A
DO NOT SCALE DRAWING			SHEET 3 OF 9

65 @@J-9K 'fHCD'L!F5MJ-9KŁ

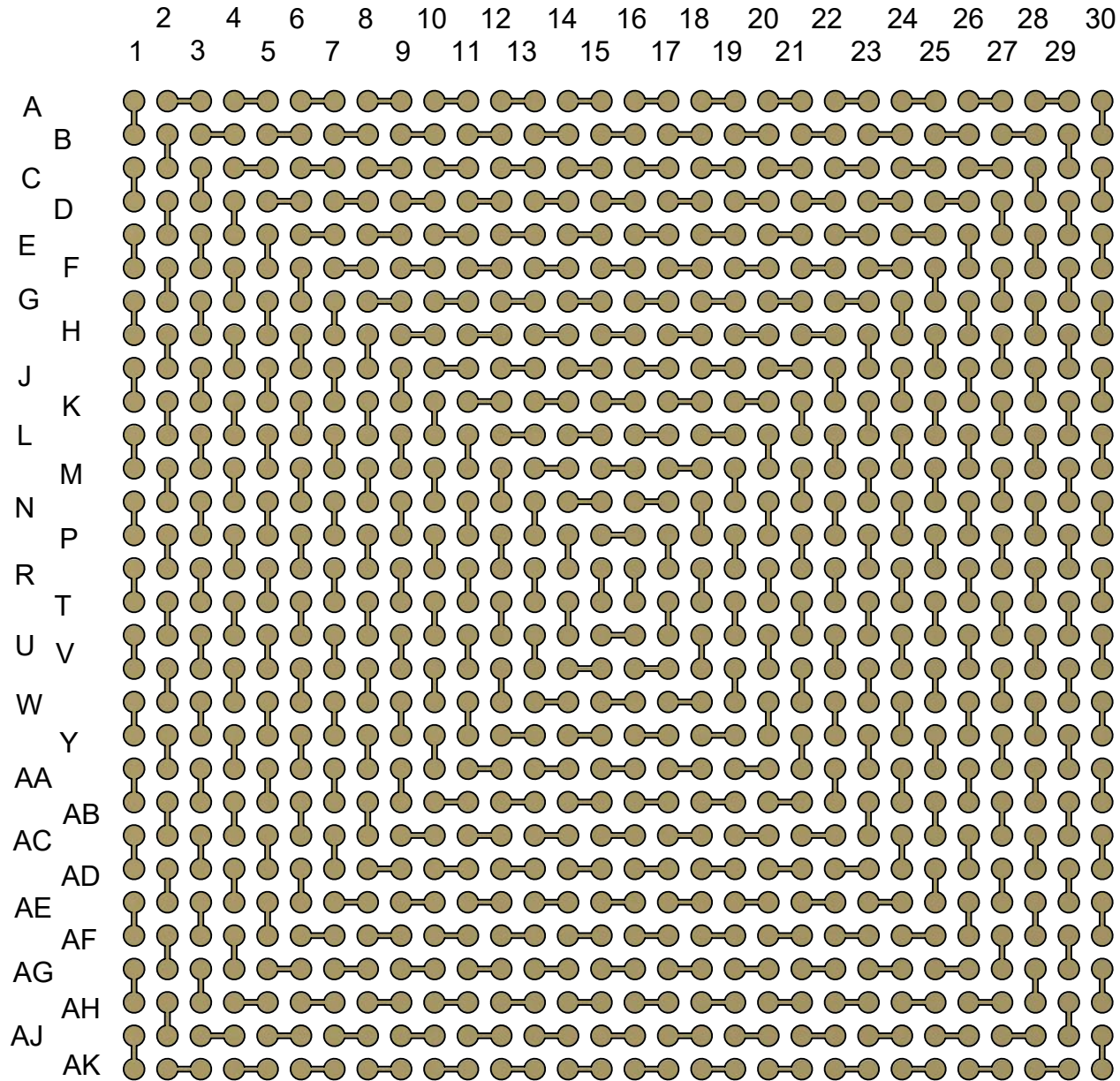

TopLine®			
TITLE		SBGA900T1.0C-DC309D DAISY CHAIN DUMMY	
SCALE	SIZE	DRAWING NO.	REV
3:1	A	513095	A
DO NOT SCALE DRAWING			SHEET 4 OF 9

H9GH'J9<=7 @ '6 C5 F8

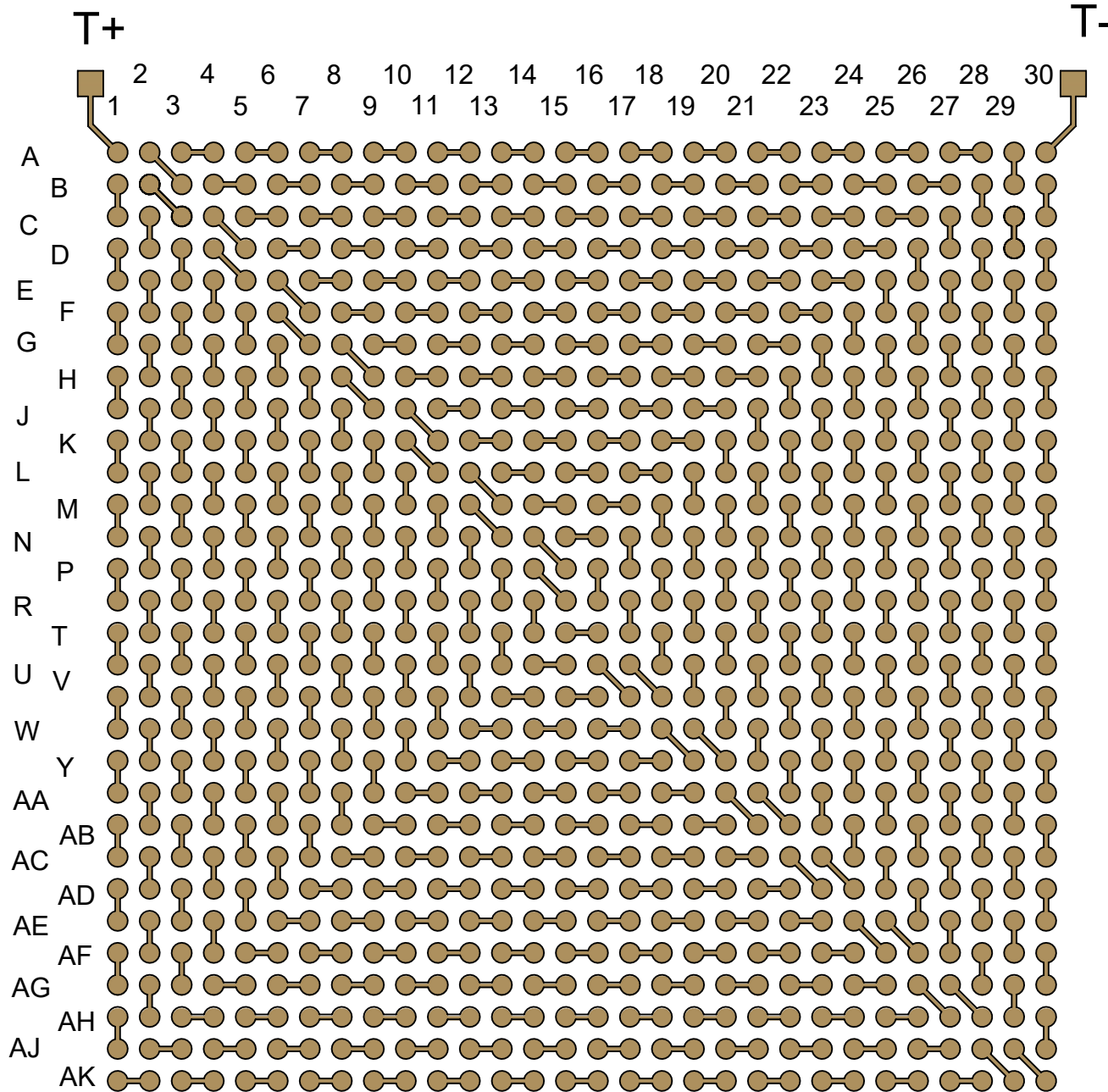

TopLine®			
TITLE		SBGA900T1.0C-DC309D DAISY CHAIN DUMMY	
SCALE	SIZE	DRAWING NO.	REV
3:1	A	513095	A
DO NOT SCALE DRAWING			SHEET 5 OF 9

5 : H9F ACI BH-B;

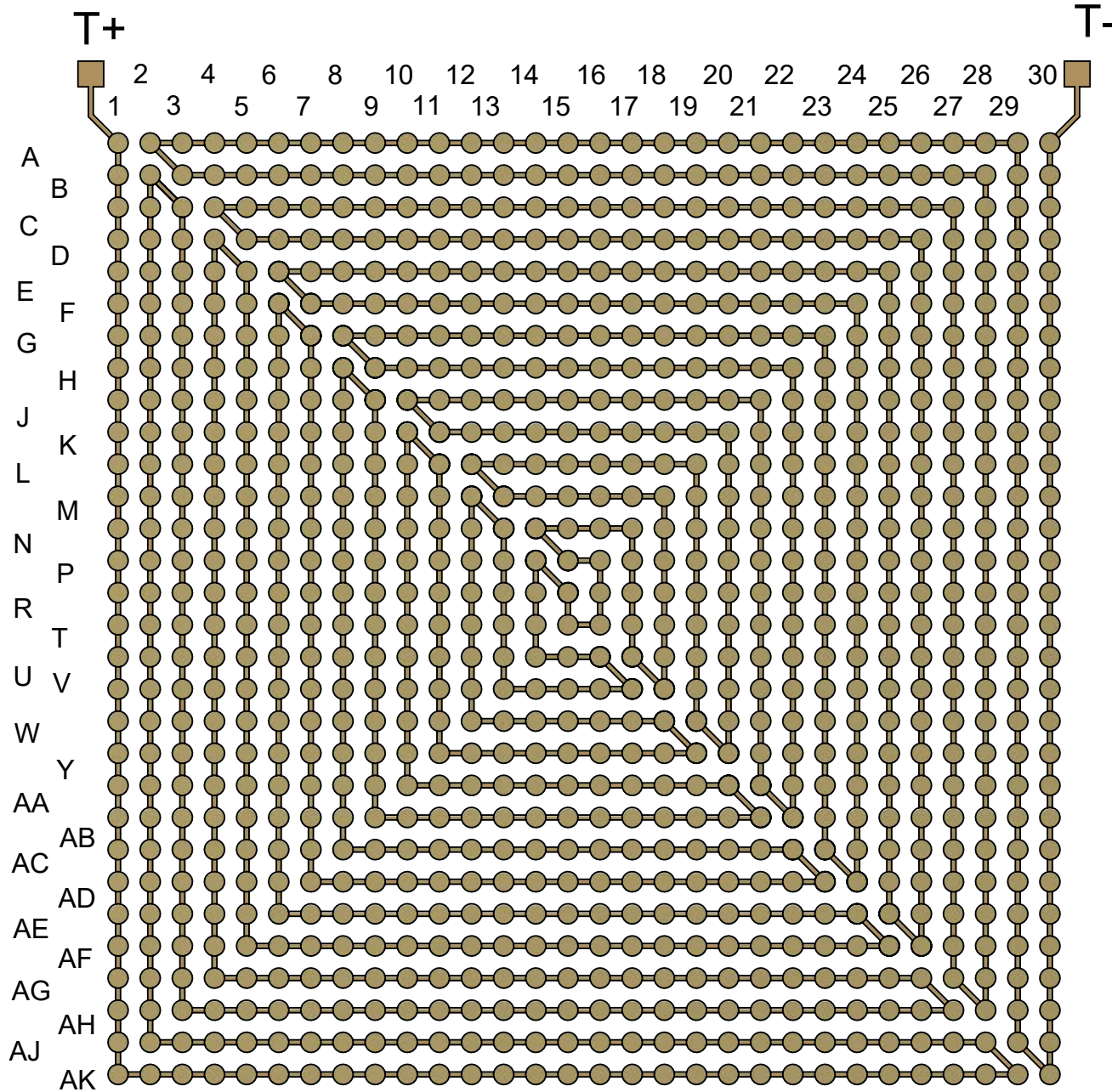

TopLine®			
TITLE		SBGA900T1.0C-DC309D DAISY CHAIN DUMMY	
SCALE	SIZE	DRAWING NO.	REV
3:1	A	513095	A
DO NOT SCALE DRAWING			SHEET 6 OF 9

<95 H'GDF9589F

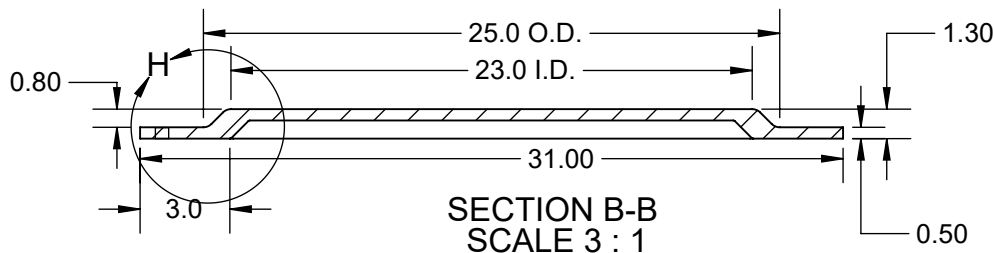
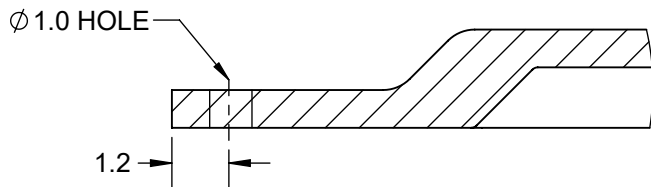
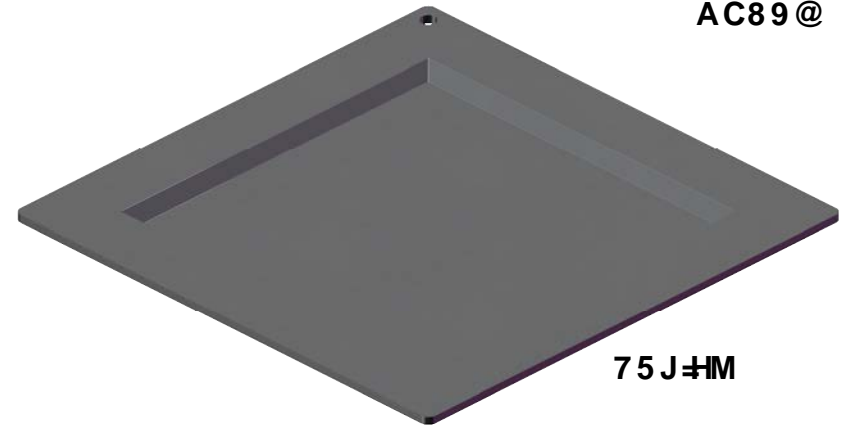
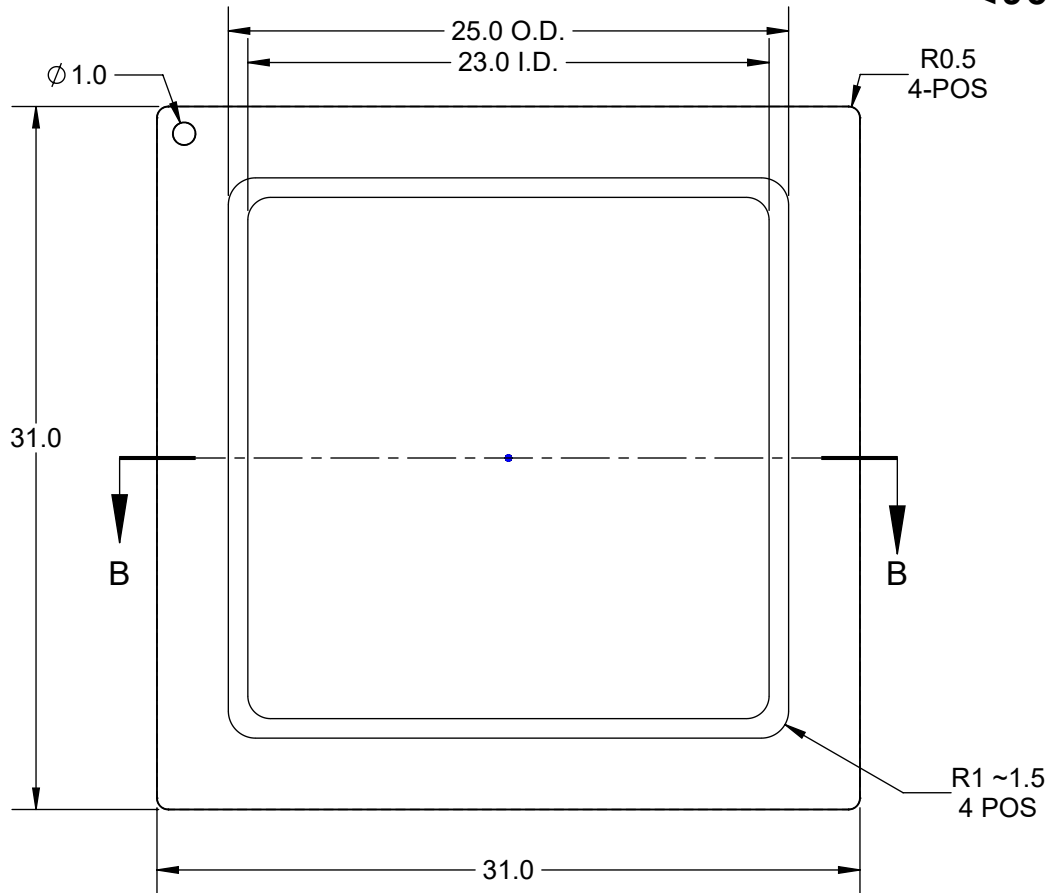

NOTES:

1. DIMENSION in MM
2. MATERIAL: COPPER ALLOY C1020 OR C1100
HALF HARD, OXYGEN FREE
3. PLATING: NICKEL 5um MIN (SEMI FINISH)

TopLine®			
TITLE SBA900T1.0C-DC309D DAISY CHAIN DUMMY			
SCALE 3:1	SIZE A	DRAWING NO. 513095	REV A
DO NOT SCALE DRAWING		SHEET 7 OF 9	

AC89@

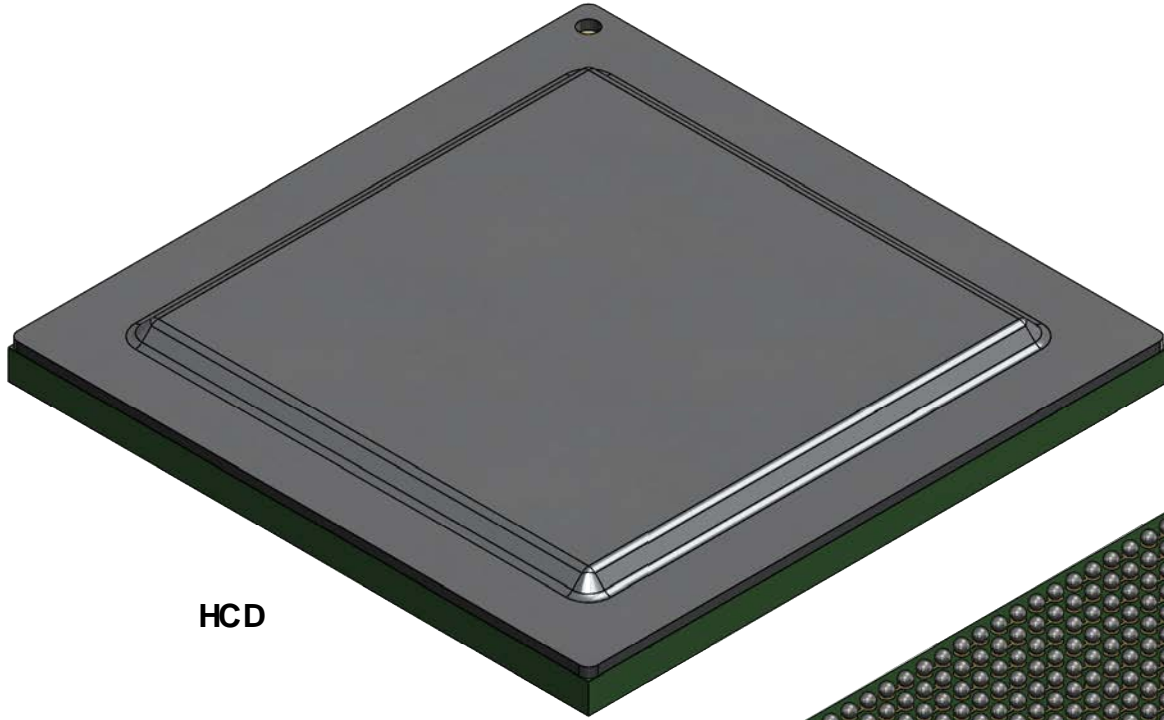

HCD

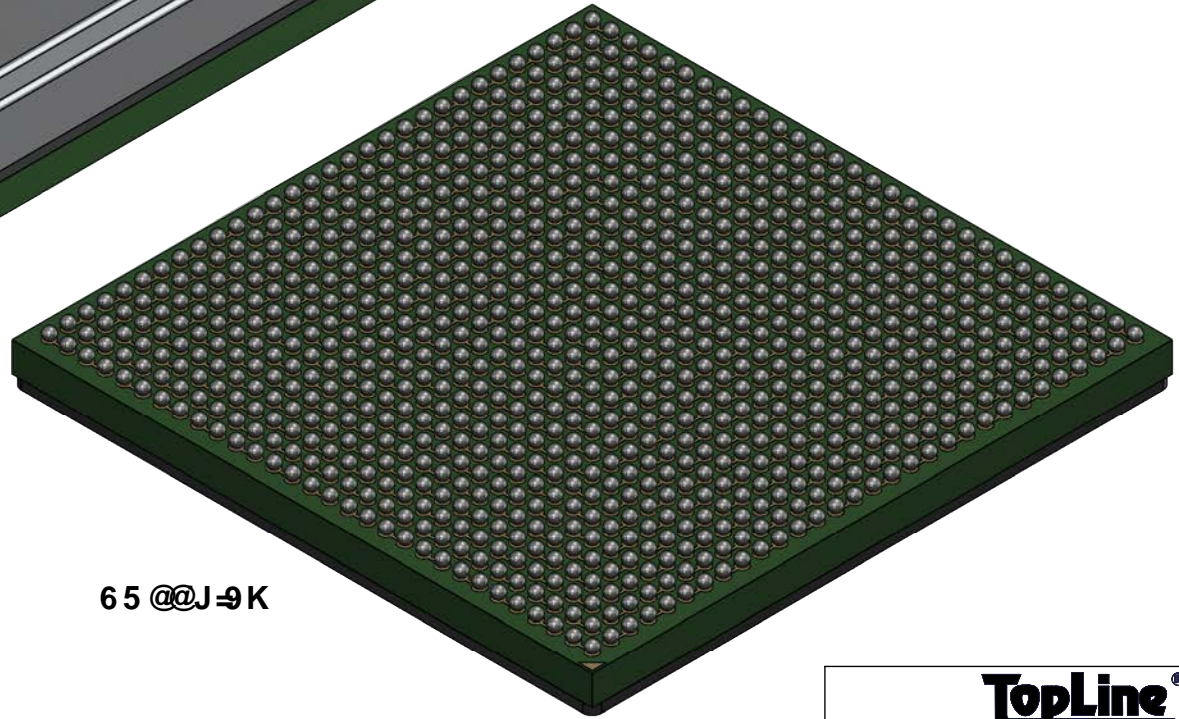

65@@J-9K

TopLine[®]

TITLE SPGA900T1.0C-DC309D
DAISY CHAIN DUMMY

SCALE	SIZE	DRAWING NO.	REV
3:1	A	513095	A

DO NOT SCALE DRAWING

SHEET 8 OF 9

6 CHHCA GC @ 9F A5 G?
 *****fF = <H'F958 =B; L

30 28 26 24 22 20 18 16 14 12 10 8 6 4 2
 29 27 25 23 21 19 17 15 13 11 9 7 5 3 1

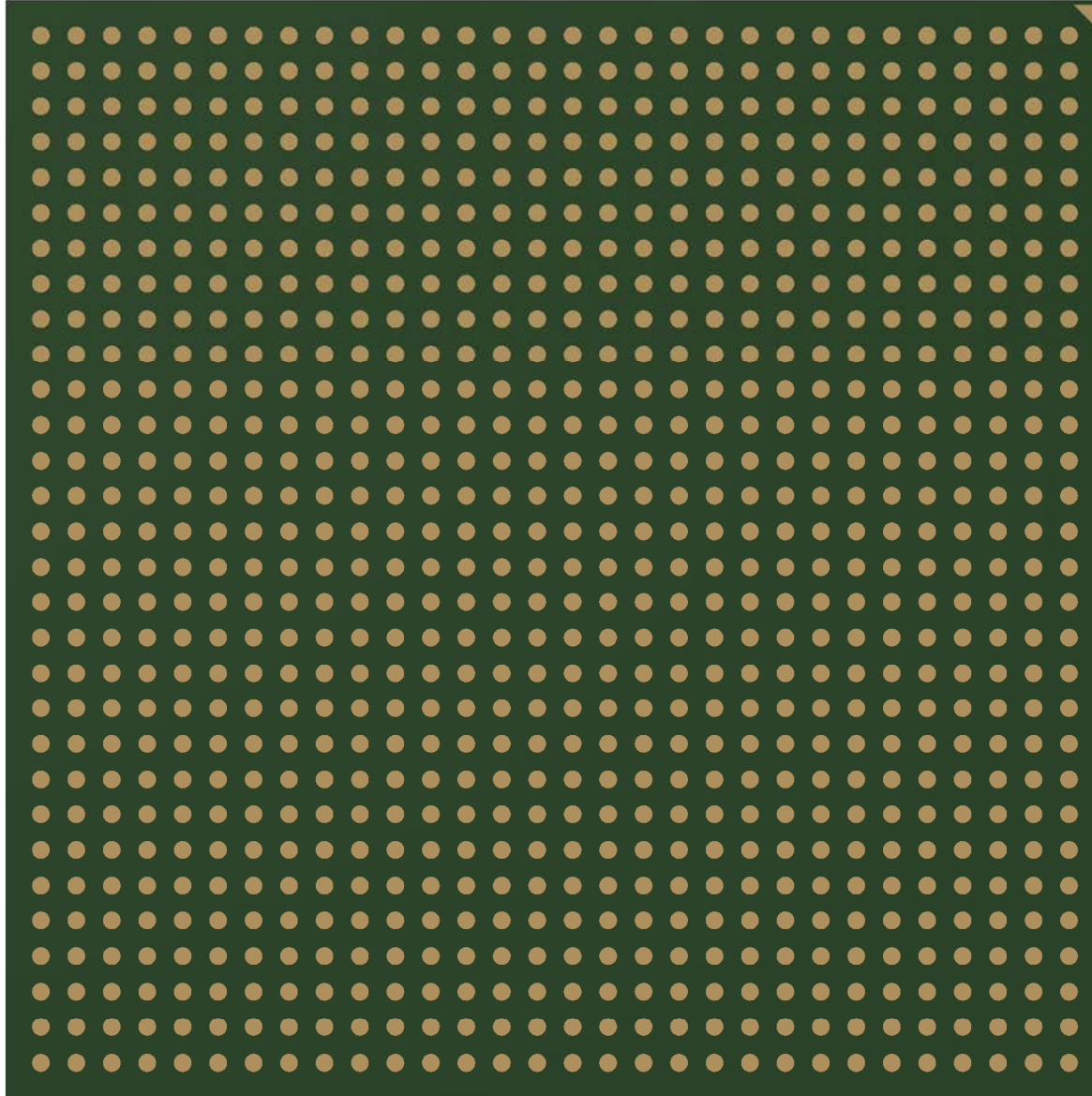

A
 B
 C
 D
 E
 F
 G
 H
 J
 K
 L
 M
 N
 P
 R
 T
 U
 V
 W
 Y
 AA
 AB
 AC
 AD
 AE
 AF
 AG
 AH
 AJ
 AK

TopLine®			
TITLE		SBSA900T1.0C-DC309D DAISY CHAIN DUMMY	
SCALE	SIZE	DRAWING NO.	REV
3:1	A	513095	A
DO NOT SCALE DRAWING			SHEET 9 OF 9