

**DIMENSION AND WEIGHT (MASS) TABLE**

H HEIGHT MAX	PCB MASS NOM	TUNGSTEN BALLS IN CAVITY				Total PID MASS	SCREW ADJUST	SCREW HEX HEAD
		Ø DIA	Per Ball	QTY	MASS			
14mm	330g	3.0mm	0.24g	~138	33g	TBA	8-32	5/64

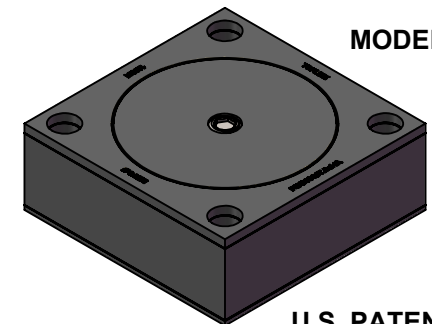

**MODEL**

**U.S. PATENTS 10041558,  
10021779, 10704639,  
10704639, D842351**

- NOTES: (Unless Otherwise Specified).  
 1. DIMENSIONS IN mm.  
 2. MOUNTING SCREW M4.5 or 8-32.  
 3. ALTERNATIVE MOUNTING ADHESIVE (GLUE).

APPROVALS	DATE	<b>TopLine®</b>			
DRAWN T. Au	6/22/2022				
ENG M. Hart	6/22/2022	TITLE FSX33SQ37.5x14A PID VIBRATION DAMPER			
MFG		SCALE	SIZE	DRAWING NO.	REV
QA		3:1	A	120331	A
CUST		DO NOT SCALE DRAWING			SHEET 1 OF 3
REVISED					

# MODEL

TOP

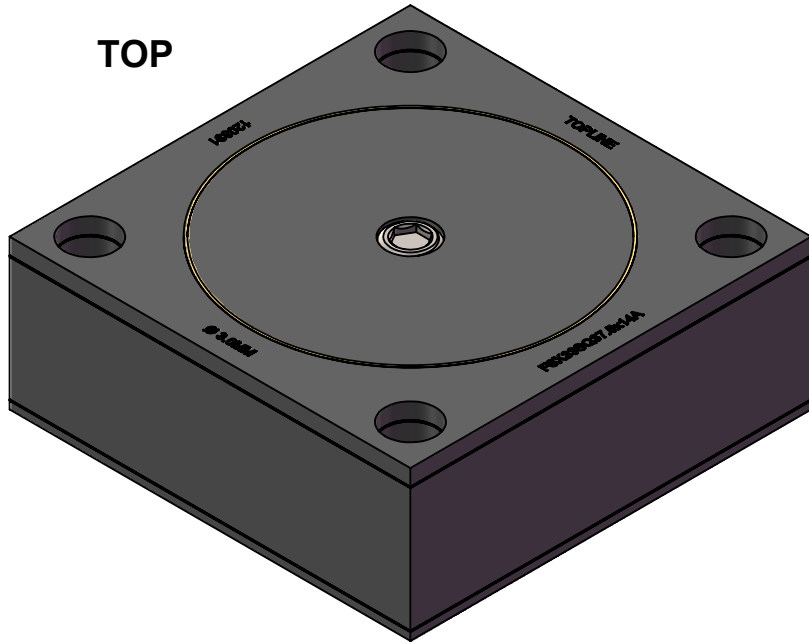

BOTTOM

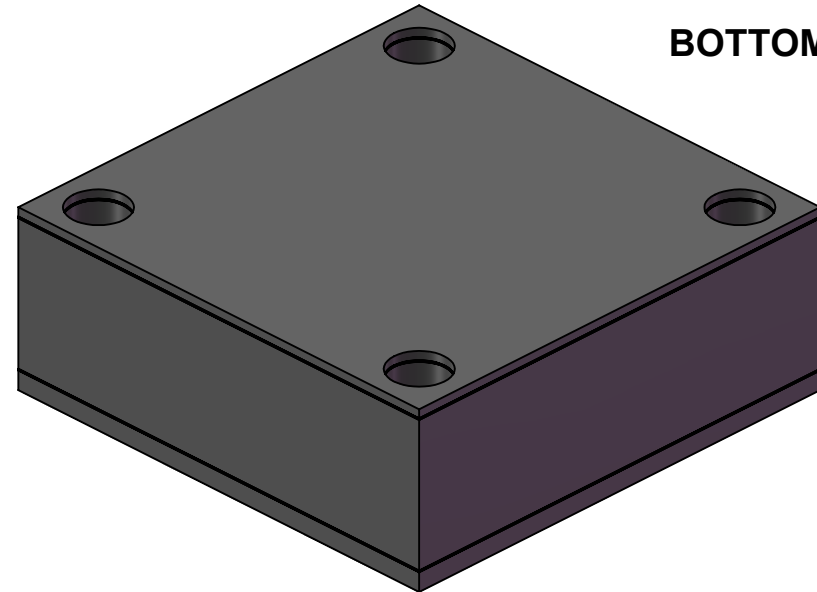

NOTES:  
1. CONTACT TOPLINE FOR OTHER MOUNTING OPTIONS.

<b>TopLine®</b>			
TITLE		FSX33SQ37.5x14A PID VIBRATION DAMPER	
SCALE	SIZE	DRAWING NO.	REV
2:1	A	120331	A
DO NOT SCALE DRAWING			SHEET 2 OF 3

## Part Number System

<u>F</u>	<u>S</u>	<u>X</u>	<u>33</u>	<u>SQ</u>	<u>37.5x</u>	<u>14</u>	<u>A</u>
Series	Mounting on PCB	Variation	Tungsten Payload Grams	Exterior Shape	XY Size	Height	Version/Option
<b><u>Filled</u></b>	<b><u>Mounting Style</u></b>	<b><u>Code</u></b>	<b><u>Code Grams</u></b>	<b><u>Code Shape</u></b>	<b><u>Code Size</u></b>	<b><u>Code Height</u></b>	<b><u>Code Version</u></b>
F = FR4 Single Layer	S = SCREW MOUNT  A = ADHESIVE GLUE	X = SPECIAL  BLANK = STANDARD	33 = 33gm  Other Mass Available	SQ Square R Rectangle C Cylindrical T Toroid Z Custom	37.5 = 37.5mm SQ  Other Sizes Available	14 = 14mm MAX  Other Sizes Available	A = Version A  Other Version Available
<b><u>Empty</u></b>							
E = FR4 Case							

## Order Number

<u>1</u>	<u>2</u>	<u>033</u>	<u>1</u>
DESCRIPTION	Mount Style	Mass (gm) 9 = Decimal	Option Code
<b><u>Code</u></b> <b><u>Description</u></b>	<b><u>Code</u></b> <b><u>Description</u></b>	<b><u>Code</u></b> <b><u>MASS</u></b>	<b><u>Code</u></b> <b><u>Option</u></b>
1 = Filled PID	2 = Screw 3 = Adhesive 9 = Custom 0 = Master DWG	033 = 33 gm	1 = Version A

**TopLine®**

TITLE    FSX33SQ37.5x14A  
PID VIBRATION DAMPER

SCALE NONE	SIZE A	DRAWING NO. 120331	REV A
---------------	-----------	-----------------------	----------

DO NOT SCALE DRAWING

SHEET 3 OF 3