

TOP

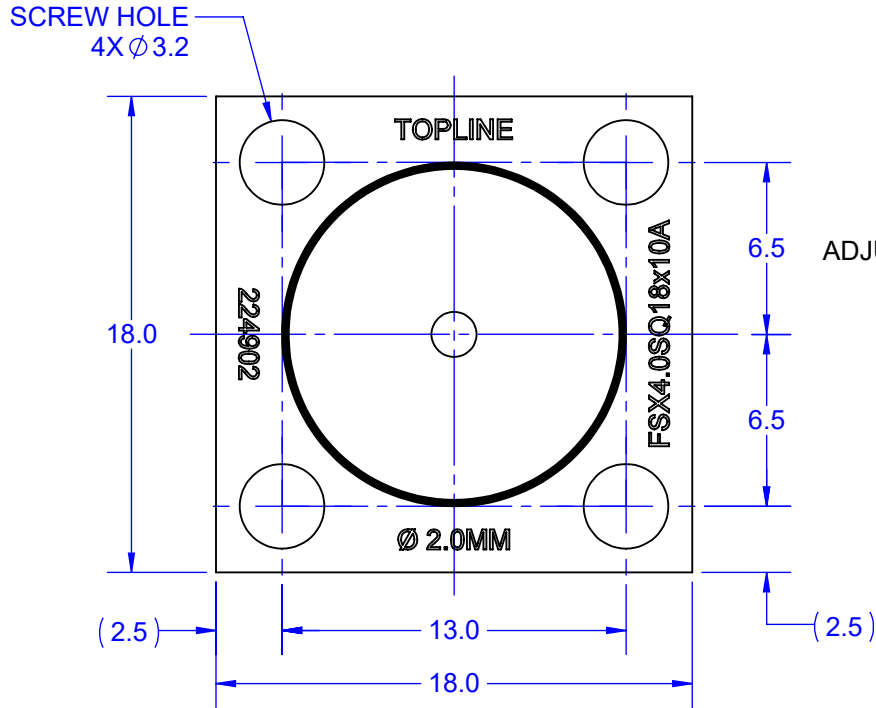

SIDE

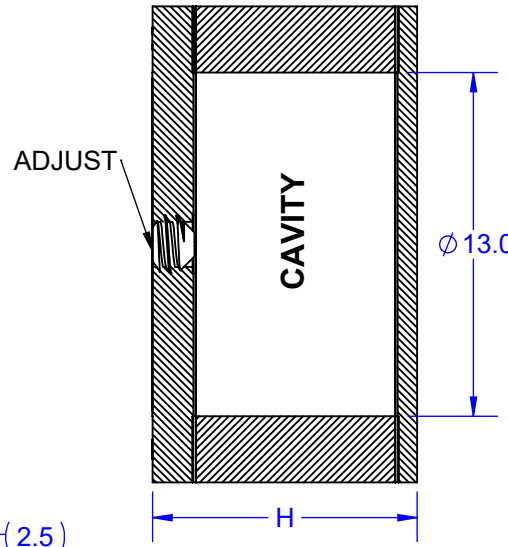

**BOTTOM
(NOTE 2)**

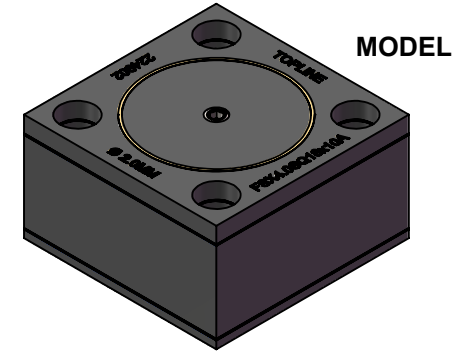
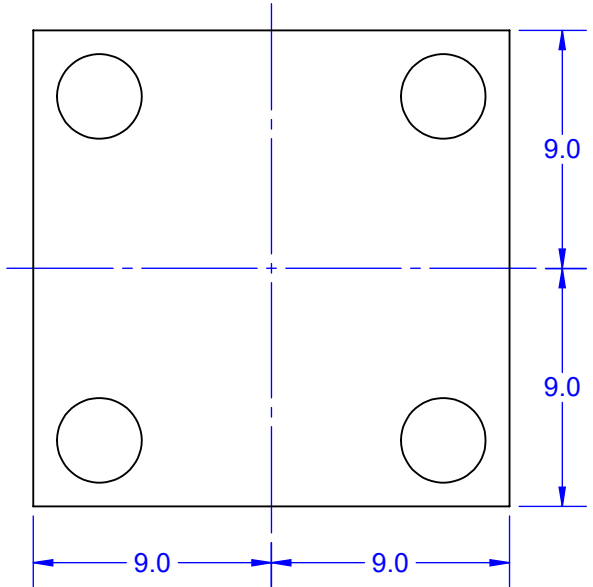

DIMENSION AND WEIGHT (MASS) TABLE

H HEIGHT MAX	PCB MASS NOM	TUNGSTEN BALLS IN CAVITY				Total PID MASS	SCREW ADJUST	SCREW HEX HEAD
		Ø DIA	Per Ball	QTY	MASS			
10mm	40g	2.0mm	0.073g	56~59	4.0g	TBA	4-40	0.050
10mm	40g	2.3mm	0.102g	38~41	4.0g	TBA	6-32	1/16

**U.S. PATENTS 10041558,
10021779, 10704639,
10704639, D842351**

NOTES: (Unless Otherwise Specified).

1. DIMENSIONS IN mm.
2. MOUNTING SCREW M3 or 4-40
3. ALTERNATIVE MOUNTING ADHESIVE (GLUE)

APPROVALS	DATE	TopLine®			
DRAWN T. Au	6/5/2022				
ENG M. Hart	6/5/2022	TITLE FSX4.0SQ18x10A PID VIBRATION DAMPER			
MFG		SCALE	SIZE	DRAWING NO.	REV
QA		3:1	A	224902	A
CUST		DO NOT SCALE DRAWING			SHEET 1 OF 3
REVISED					

MODEL

TOP

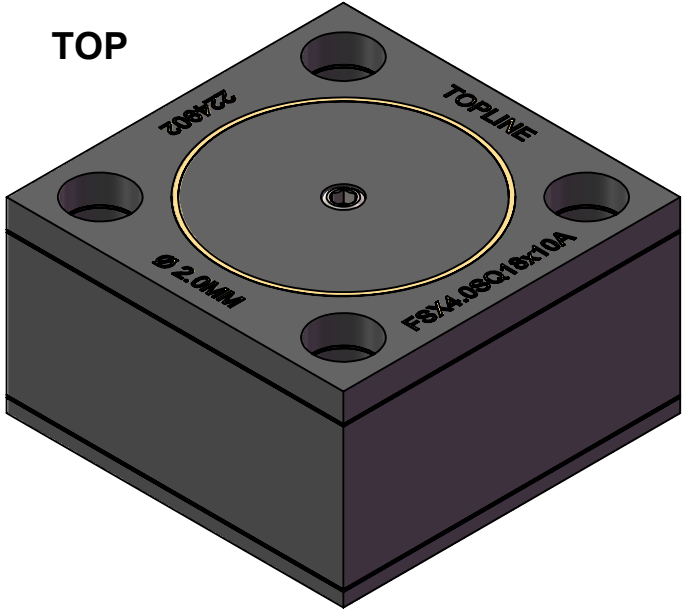

BOTTOM

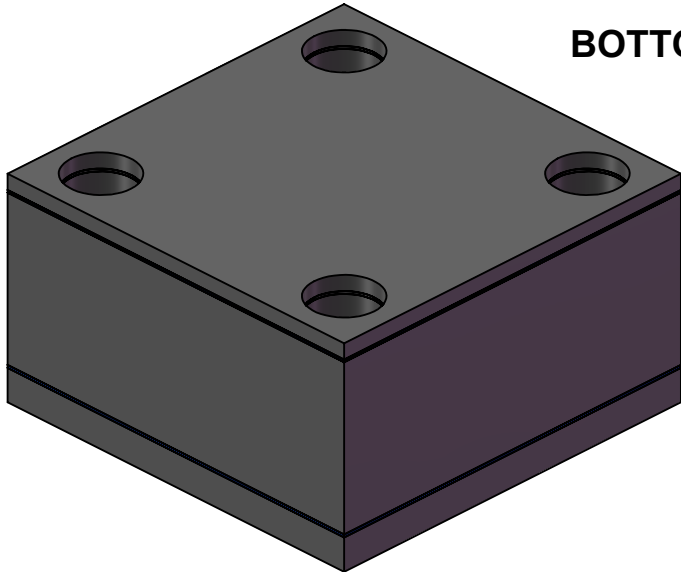

NOTES:
1. CONTACT TOPLINE FOR OTHER MOUNTING OPTIONS.

TopLine®			
TITLE		FSX4.0SQ18x10A PID VIBRATION DAMPER	
SCALE	SIZE	DRAWING NO.	REV
3:1	A	224902	A
DO NOT SCALE DRAWING			SHEET 2 OF 3

Part Number System

<u>F</u>	<u>S</u>	<u>X</u>	<u>4.0</u>	<u>SQ</u>	<u>18x</u>	<u>10</u>	<u>A</u>
Series	Mounting on PCB	Variation	Tungsten Payload Grams	Exterior Shape	X/Y Size	Height	Version/Option
<u>Filled</u>	<u>Mounting Style</u>	<u>Code</u>	<u>Code Grams</u>	<u>Code Shape</u>	<u>Code Size</u>	<u>Code Height</u>	<u>Code Version</u>
F = FR4 Single Layer	S = SCREW MOUNT A = ADHESIVE GLUE	X = SPECIAL	4.0 = 4.0gm Other Mass Available	SQ Square R Rectangle C Cylindrical T Toroid Z Custom	18x = 18mm SQ Other Sizes Available	10= 10mm MAX Other Sizes Available	A Standard Other Version Available
<u>Empty</u>							
E = FR4 Case							

Order Number

<u>2</u>	<u>2</u>	<u>490</u>	<u>2</u>
DESCRIPTION	Mount Style	Mass (gm) 9 = Decimal	Option Code
<u>Code</u> <u>Description</u>	<u>Code</u> <u>Description</u>	<u>Code</u> <u>MASS</u>	<u>Code</u> <u>Option</u>
2 = Filled PID	2 = Screw 3 = Adhesive 9 = Custom 0 = Master DWG	490 = 4.0 gm	2 = Version A

TopLine®

TITLE FSX4.0SQ18x10A
PID VIBRATION DAMPER

SCALE NONE	SIZE A	DRAWING NO. 224902	REV A
---------------	-----------	-----------------------	----------

DO NOT SCALE DRAWING

SHEET 3 OF 3