

TOP VIEW

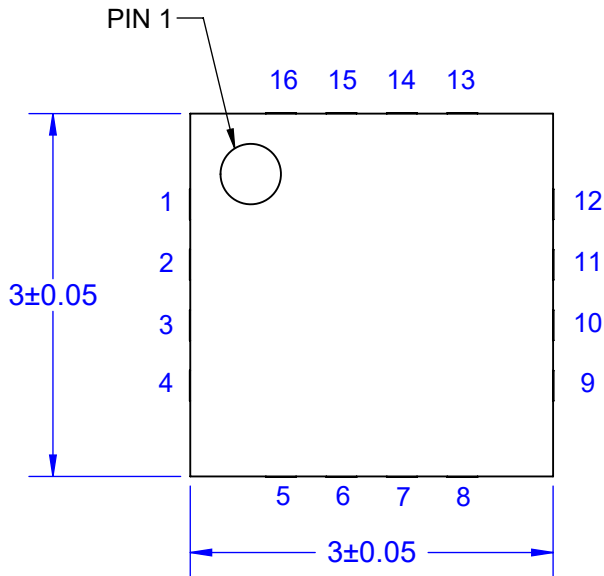

SIDE VIEW

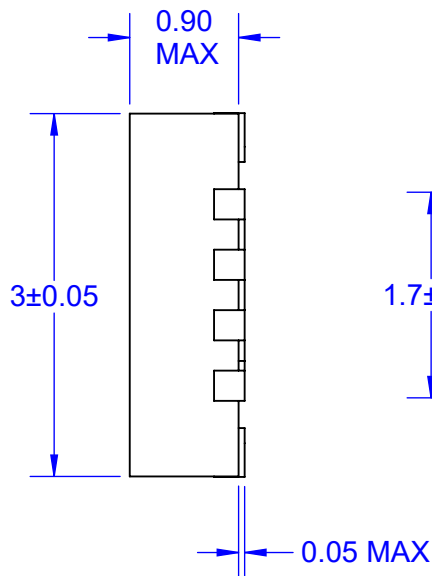

BOTTOM VIEW

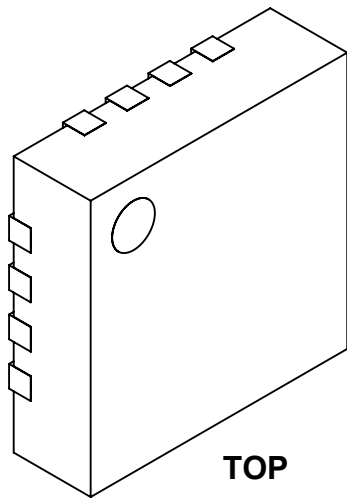
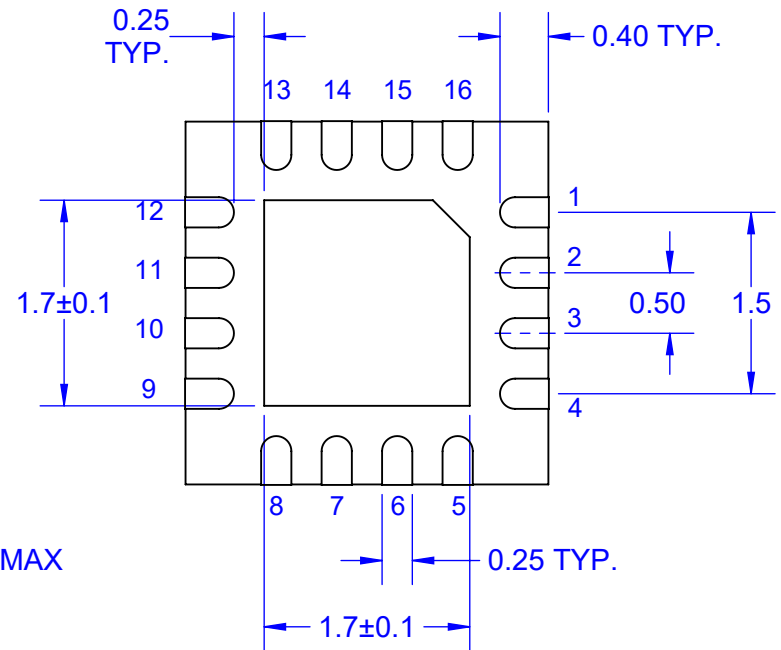

MODEL

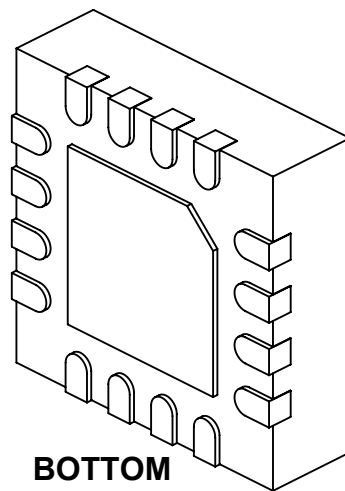

Notes: (Unless Otherwise Specified).

- 1) BODY: PLASTIC, SEMICONDUCTOR GRADE.
- 2) LEAD FRAME: COPPER, C-194 F/H.
- 3) LEAD FRAME PLATING: Sn MATTE TIN.
- 4) FRAME THICKNESS: 0.203mm.
- 5) DIE PAD: 1.7 X 1.7 mm EXPOSED BOTTOM.
- 6) JEDEC OUTLINE: MO-220.
- 7) DIMENSIONS IN mm.

APPROVALS	DATE	TopLine®			
DRAWN T. Au	2/24/2024				
ENG M. Hart	2/24/2024	TITLE 16-LEAD 3mm P0.5mm QFN DAISY CHAIN			
MFG		SCALE	SIZE	DRAWING NO.	REV
QA		16:1	A	451645	A
CUST		DO NOT SCALE DRAWING			SHEET 1 OF 5
REVISED					

DAISY CHAIN PATTERN

TOP VIEW

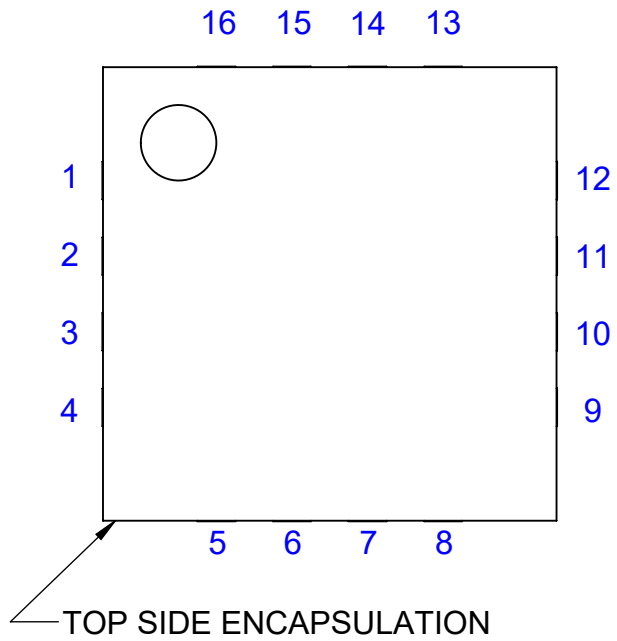

SIDE VIEW

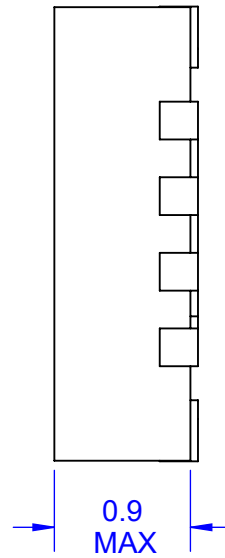

BOTTOM VIEW

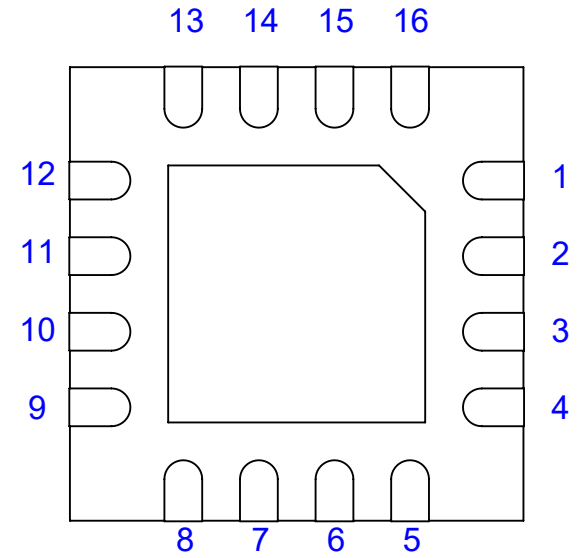

NOTE:
1. PACKAGE DAISY CHAIN BY WIRE BONDING TO INTERNAL BOND PADS.

TopLine[®]

TITLE 16-LEAD 3mm P0.5mm
QFN DAISY CHAIN

SCALE 20:1	SIZE A	DRAWING NO. 451645	REV A
---------------	-----------	-----------------------	----------

DO NOT SCALE DRAWING

SHEET 2 OF 5

16L QFN DAISY CHAIN TOP VIEW

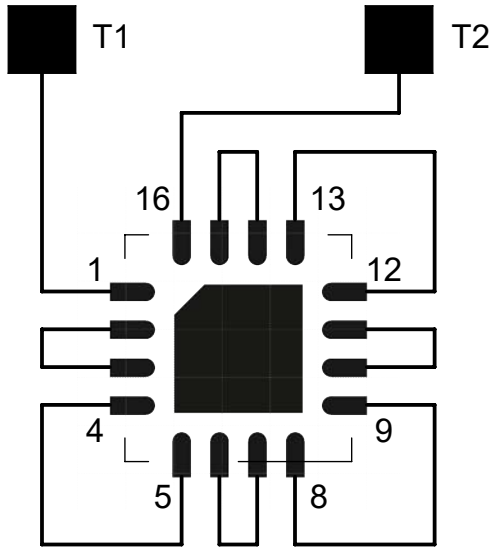

**RECOMMENDED
PCB PADS**

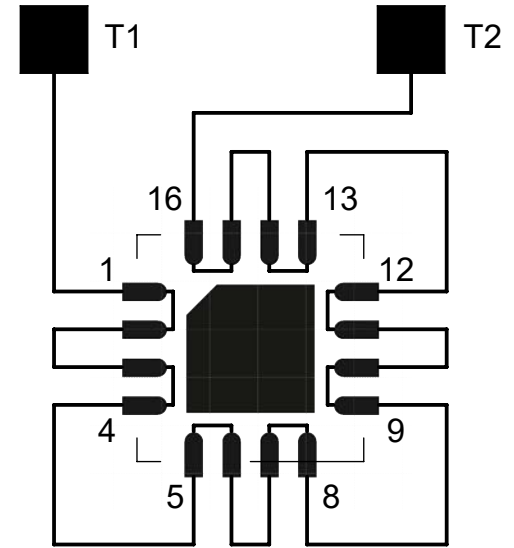

**AFTER MOUNTING
ON PCB**

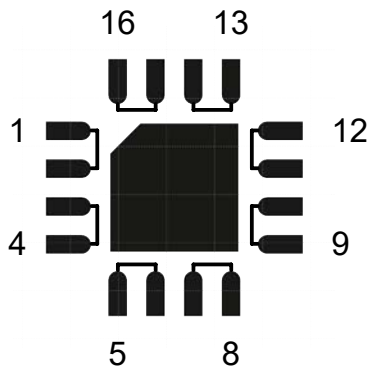

VIEW FROM TOP

DAISY CHAIN NET LIST

PINS	PINS
1 ~ 2	3 ~ 4
5 ~ 6	7 ~ 8
9 ~ 10	11 ~ 12
13 ~ 14	15 ~ 16

TopLine®

TITLE 16-LEAD 3mm P0.5mm
QFN DAISY CHAIN

SCALE 10:1	SIZE A	DRAWING NO. 451645	REV A
---------------	-----------	-----------------------	----------

DO NOT SCALE DRAWING

SHEET 3 OF 5

PC BOARD LAYOUT DIMENSIONS IN MM VIEW FROM TOP

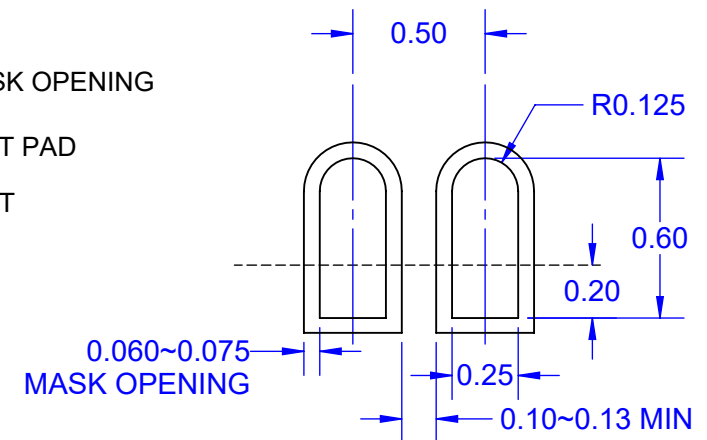
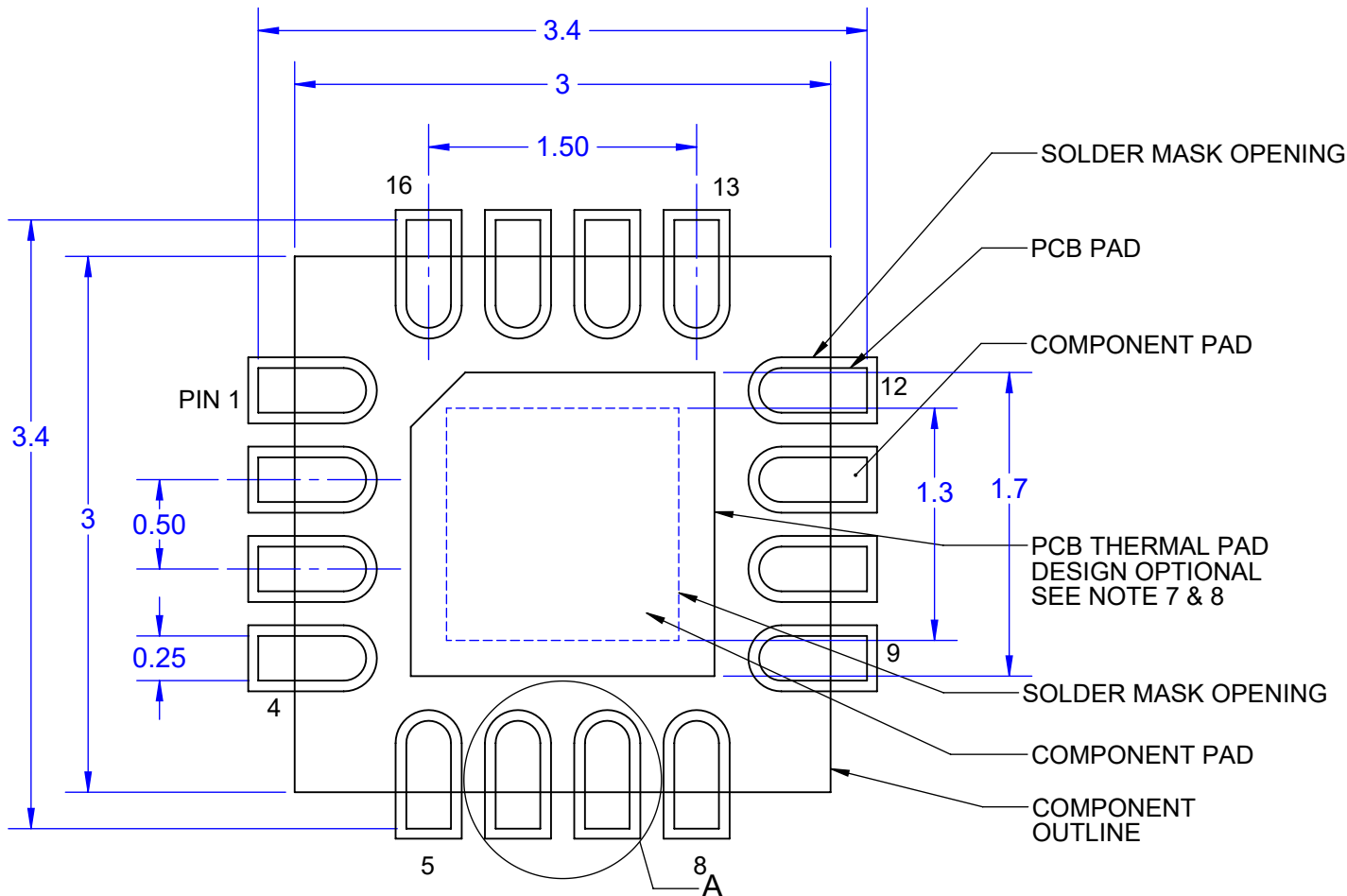

DETAIL A
SCALE 35 : 1

Notes: (Unless Otherwise Specified).

- 1) DIMENSIONS ARE PRESENTED ONLY AS A GUIDELINE. DESIGNERS SHOULD USE THEIR OWN KNOWLEDGE BASE WHEN DESIGNING THE PCB.
- 2) SURROUND EACH SIDE OF I/O PERIMETER PADS WITH 0.060~0.075 mm (NSMD) SOLDER MASK OPENING (2.4~3.0mils) OPTIONALLY OK TO USE RECTANGLE (NSMD) MASK OPENING AROUND I/O PADS.
- 3) ROUNDED PCB LAND PADS REDUCE SOLDER BRIDGING. PAD CHAMFER ANGLE MAY VARY.
- 4) PCB LANDS SHOULD BE 0.2mm LONGER THAN THE PACKAGE I/O PADS.
- 5) THE WIDTH OF PERIMETER PCB PADS SHOULD MATCH (1:1) THE WIDTH OF THE PACKAGE PADS.
- 6) REFER TO INDUSTRY REFERENCES SUCH AS IPC-SM-782 FOR PCB LAND PATTERN DESIGN.
- 7) THERMAL GROUND PADS MAY BE CHANGED TO SUITE REQUIREMENTS OF THE DESIGNER.
 - A) MAKE COPPER THERMAL PAD AS LARGE AS POSSIBLE.
 - B) DRILL MULTIPLE THERMAL VIAS 0.25~0.33mm DIAMETER USING 0.8~1.2mm PITCH GRID.
 - C) PLATE THERMAL VIA BARRELS WITH 1-OUNCE COPPER (18 μ m).
 - D) TENT (COVER) THERMAL VIAS WITH SOLDER MASK 0.1mm LARGER THAN THE VIA DIAMETER.
- 8) STENCIL DESIGN MAY BE CHANGED TO SUIT REQUIREMENTS OF THE DESIGNER.
 - A) LASER CUT STENCIL 0.125mm (5mil) THICK. APERTURE SIZE-TO-LAND RATIO OF 1:1.
 - B) THE SOLDER PASTE OPENING IN THE THERMAL PAD AREA SHOULD BE A MATRIX ARRAY OF SMALLER APERTURES INSTEAD OF ONE LARGE APERTURE TO CONTROL PASTE AMOUNTS.
 - C) APPLY 50% TO 80% SOLDER PASTE COVERAGE IN THE PAD AREA.

TopLine[®]

TITLE 16-LEAD 3mm P0.5mm
QFN DAISY CHAIN

SCALE	SIZE	DRAWING NO.	REV
25:1	A	451645	A

DO NOT SCALE DRAWING

SHEET 4 OF 5

PART NUMBERING SYSTEM



QUAD FLAT
NO LEAD
16-LEADS

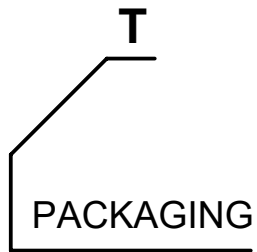

M = TUBE
T = TRAY
E = CUT TAPE
E7A = 7" REEL
E13A = 13" REEL

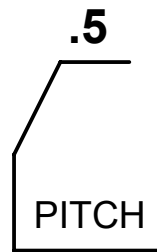

.5 = 0.5mm

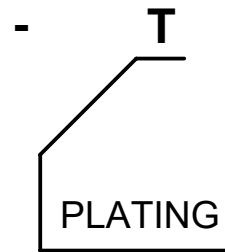

T = Sn100
MATTE TIN

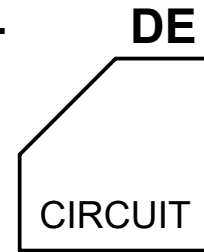

DE = DAISY CHAIN
ISO = ISOLATED
BLANK = DUMMY

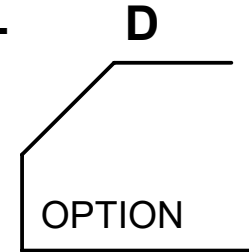

BLANK = DUMMY
D = DUMMY DIE

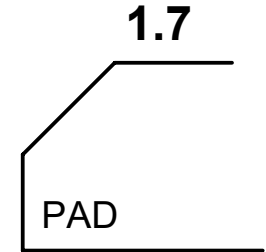

MAXIMUM
EXPOSED
PAD (mm)

PART NUMBER	DAISY CHAIN	PACKAGING	RoHS Pb-FREE	Plating	DUMMY DIE
QFN16T.5-T-DE-D1.7	YES	JEDEC TRAY	YES	Sn100	YES
QFN16T.5E7A-T-DE-D1.7	YES	TAPE & REEL	YES	Sn100	YES
QFN16T.5E13A-T-DE-D1.7	YES	TAPE & REEL	YES	Sn100	YES
QFN16T.5E-T-DE-D1.7	YES	CUT TAPE	YES	Sn100	YES
QFN16T.5-T-ISO	ISOLATED	JEDEC TRAY	YES	Sn100	NO

OTHER PART NUMBER COMBINATIONS AVAILABLE. CONTACT TOPLINE.

TopLine®			
TITLE		16-LEAD 3mm P0.5mm QFN DAISY CHAIN	
SCALE	SIZE	DRAWING NO.	REV
NONE	A	451645	A
DO NOT SCALE DRAWING			SHEET 5 OF 5