

6x FIDUCIAL A~F

**eWLP256T.2-DC168D**  
4.0 x 4.0mm

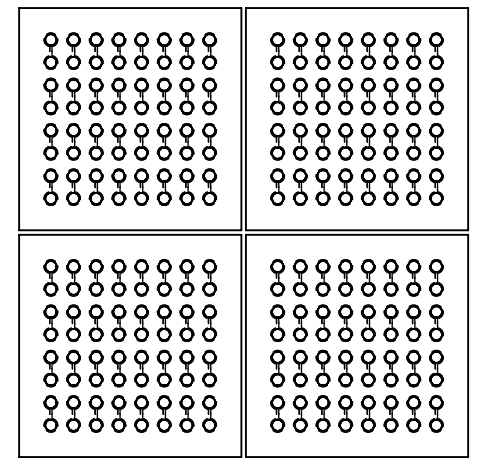

WAFER CENTER

NOTCH  
1696 CHIPS 256L  
4 x 4mm

1. DIMENSIONS MM.

<b>TopLine®</b>			
TITLE eWLP256T.2-DC168D DAISY CHAIN COPPER PAD DIE			
SCALE 1:1.25	SIZE A	DRAWING NO. 621680	REV A
DO NOT SCALE DRAWING		SHEET 1 OF 4	

**STREETS AND AVENUES  
INDEX FROM FIDUCIALS**

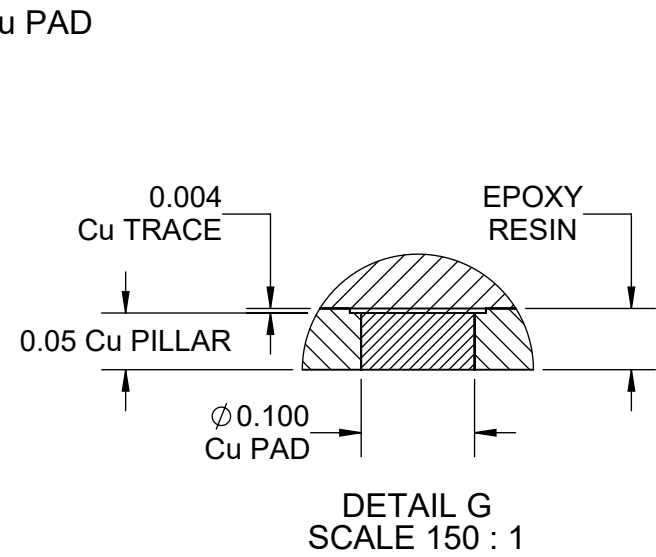
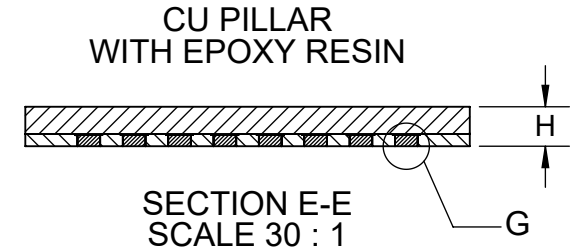
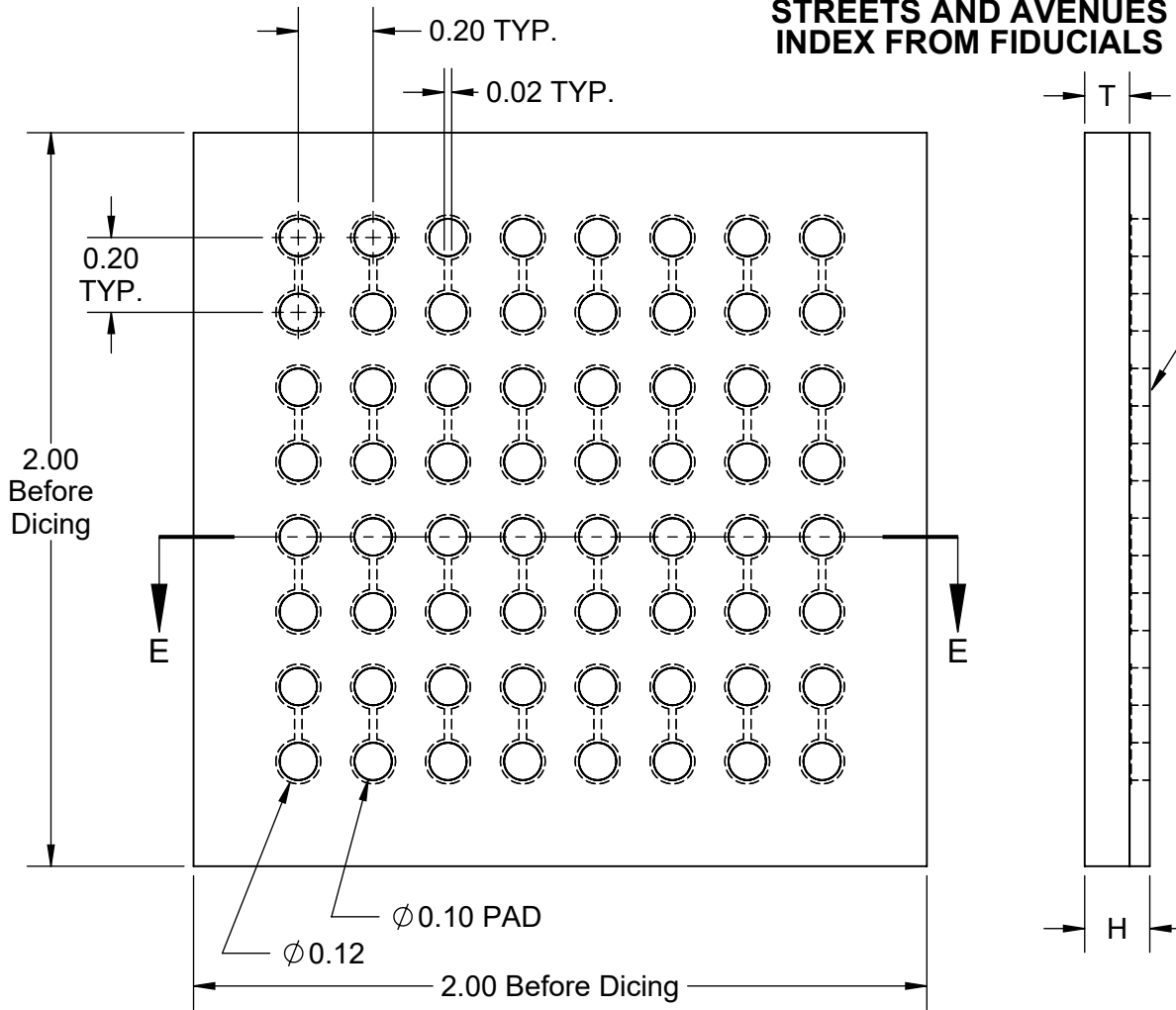

DIE THICKNESS OPTIONS		
CODE	THICKNESS Si DIE (T)	TOTAL THICKNESS WITHOUT BUMPS (H)
D2	0.230mm	0.280mm
D3	0.310mm	0.360mm
D4	0.360mm	0.410mm
D6	0.620mm	0.670mm

NOTES:  
1. DIMENSIONS MM UNLESS OTHERWISE STATED.

<b>TopLine®</b>			
TITLE eWLP256T.2-DC168D DAISY CHAIN COPPER PAD DIE			
SCALE 50:1	SIZE A	DRAWING NO. 621680	REV A
DO NOT SCALE DRAWING			SHEET 2 OF 4

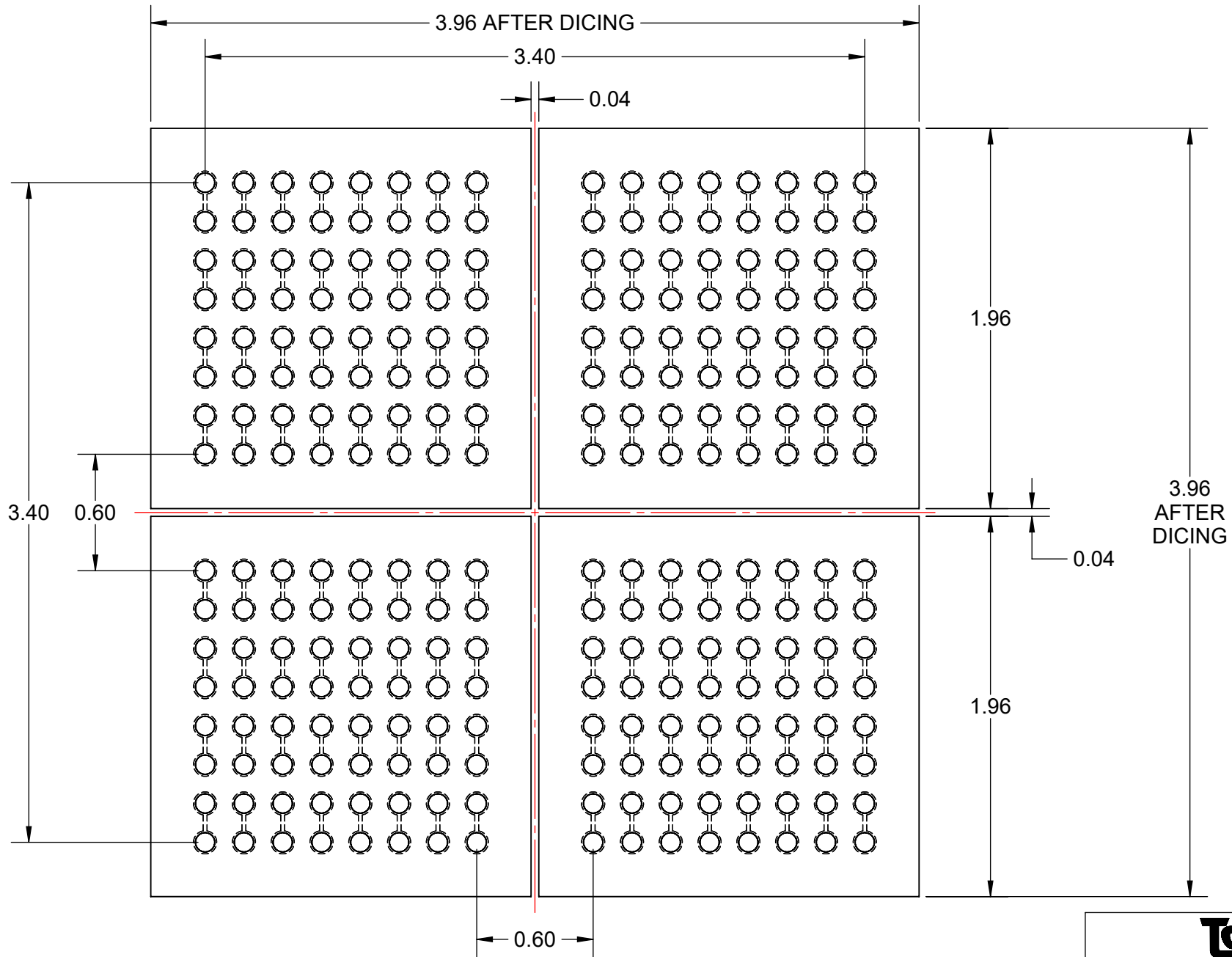

1. DIMENSIONS MM.

**TopLine®**

TITLE eWLP256T.2-DC168D  
DAISY CHAIN COPPER PAD DIE

SCALE	SIZE	DRAWING NO.	REV
35:1	A	621680	A

# PART NUMBERING SYSTEM

**eWLP**

**256**

**SERIES**

eWLP = COPPER PADS WITHOUT BUMPS

**NUMBER OF PADS**

PADS	SIZE
64	2.0x2.0mm
256	4.0x4.0mm
576	6.0x6.0mm
1024	8.0x8.0mm
1600	10x10mm
2304	12x12mm
3136	14x14mm
4096	16x16mm
999	Full Wafer

**T**

**.2**

-

**DC168**

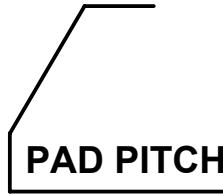

.2 = 0.2mm  
200µm

**PACKAGING**

CODE	PACKAGE
W	2" TRAY
T	4" TRAY
E	TAPE & REEL
U	UV TAPE & RING
X	UNSAW WAFER

**D**

**2**

**DIE THICKNESS**

CODE	THICKNESS
2	200µm
3	360µm
6	670µm

**PADS FACE UP/DOWN**

D = COPPER PADS DOWN  
U = COPPER PADS UP



TITLE eWLP256T.2-DC168D  
DAISY CHAIN COPPER PAD DIE

SCALE	SIZE	DRAWING NO.	REV
NONE	A	621680	A