

6x FIDUCIAL A~F

**eWLP576T.2-DC248D**  
**6.0 x 6.0mm**

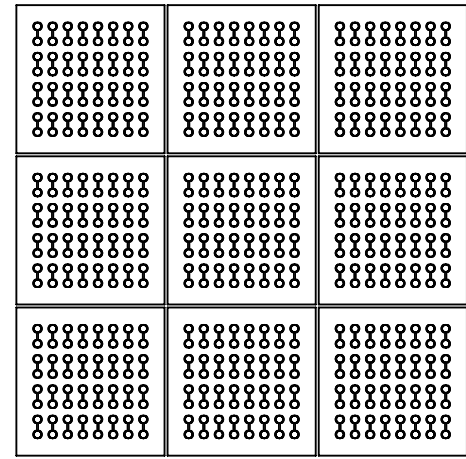

1. DIMENSIONS MM.

732 CHIPS 576L  
 6 x 6mm



TITLE eWLP576T.2-DC248D DAISY CHAIN UNSAWN WAFER			
SCALE 1:1.25	SIZE A	DRAWING NO. 622480	REV A
DO NOT SCALE DRAWING		SHEET 1 OF 4	

**STREETS AND AVENUES  
INDEX FROM FIDUCIALS**

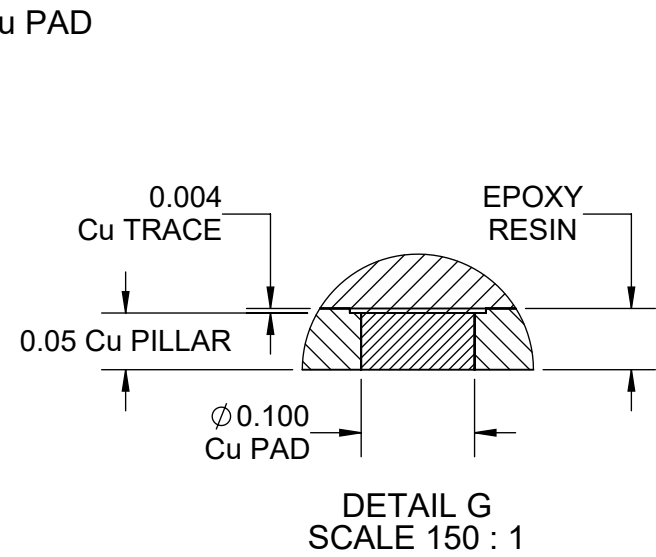
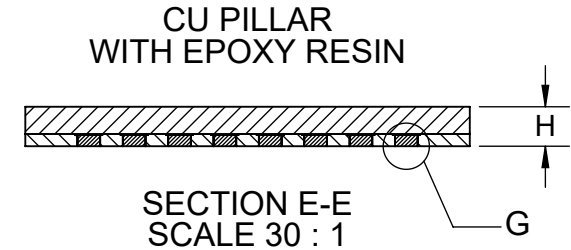
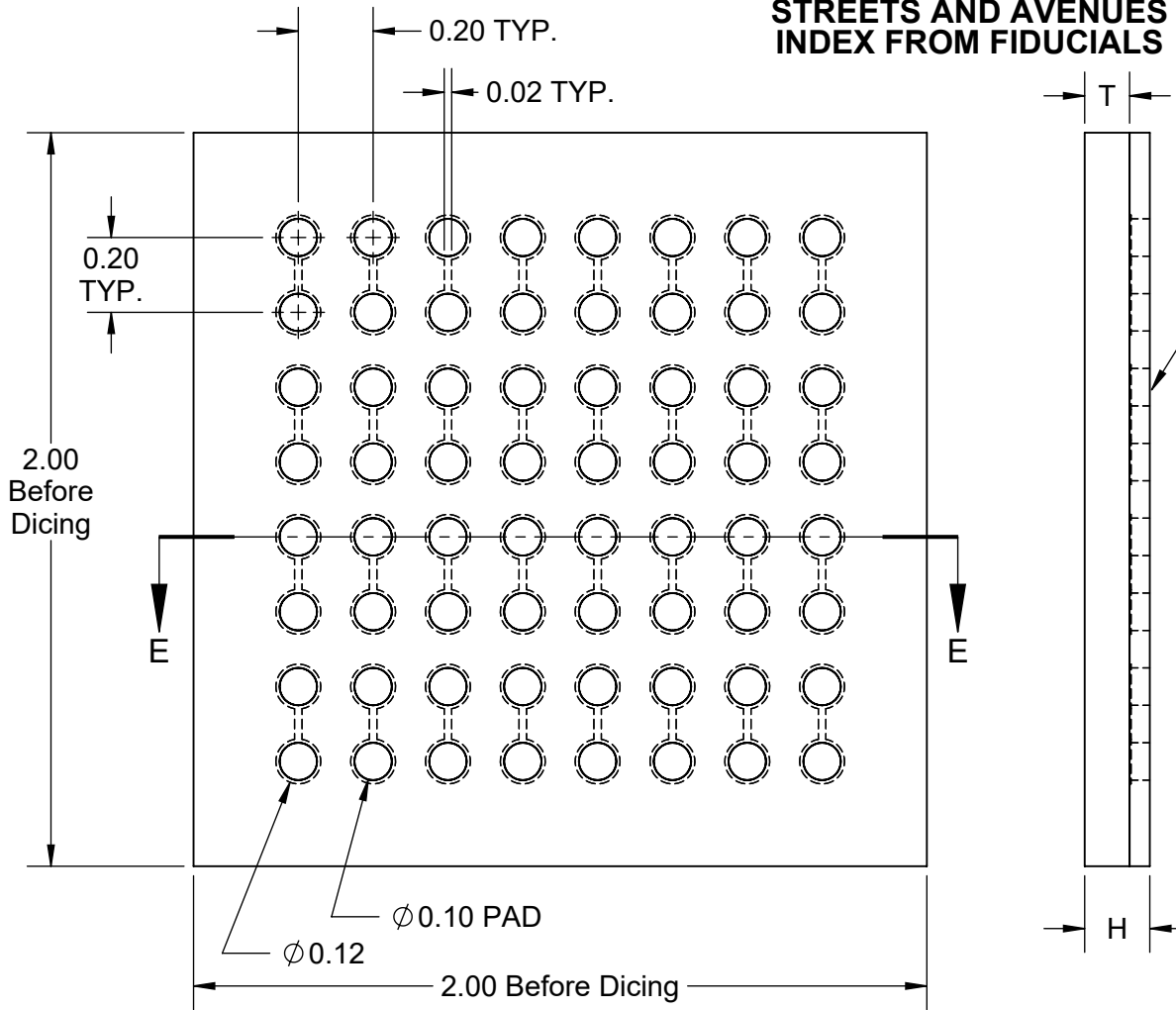

DIE THICKNESS OPTIONS		
CODE	THICKNESS Si DIE (T)	TOTAL THICKNESS WITHOUT BUMPS (H)
2	0.230mm	0.280mm
3	0.310mm	0.360mm
4	0.360mm	0.410mm
6	0.620mm	0.670mm

NOTES:  
1. DIMENSIONS MM UNLESS OTHERWISE STATED.

**TopLine®**

TITLE eWLP576T.2-DC248D  
DAISY CHAIN COPPER PAD DIE

SCALE 50:1	SIZE A	DRAWING NO. 622480	REV A
---------------	-----------	-----------------------	----------

DO NOT SCALE DRAWING      SHEET 2 OF 4

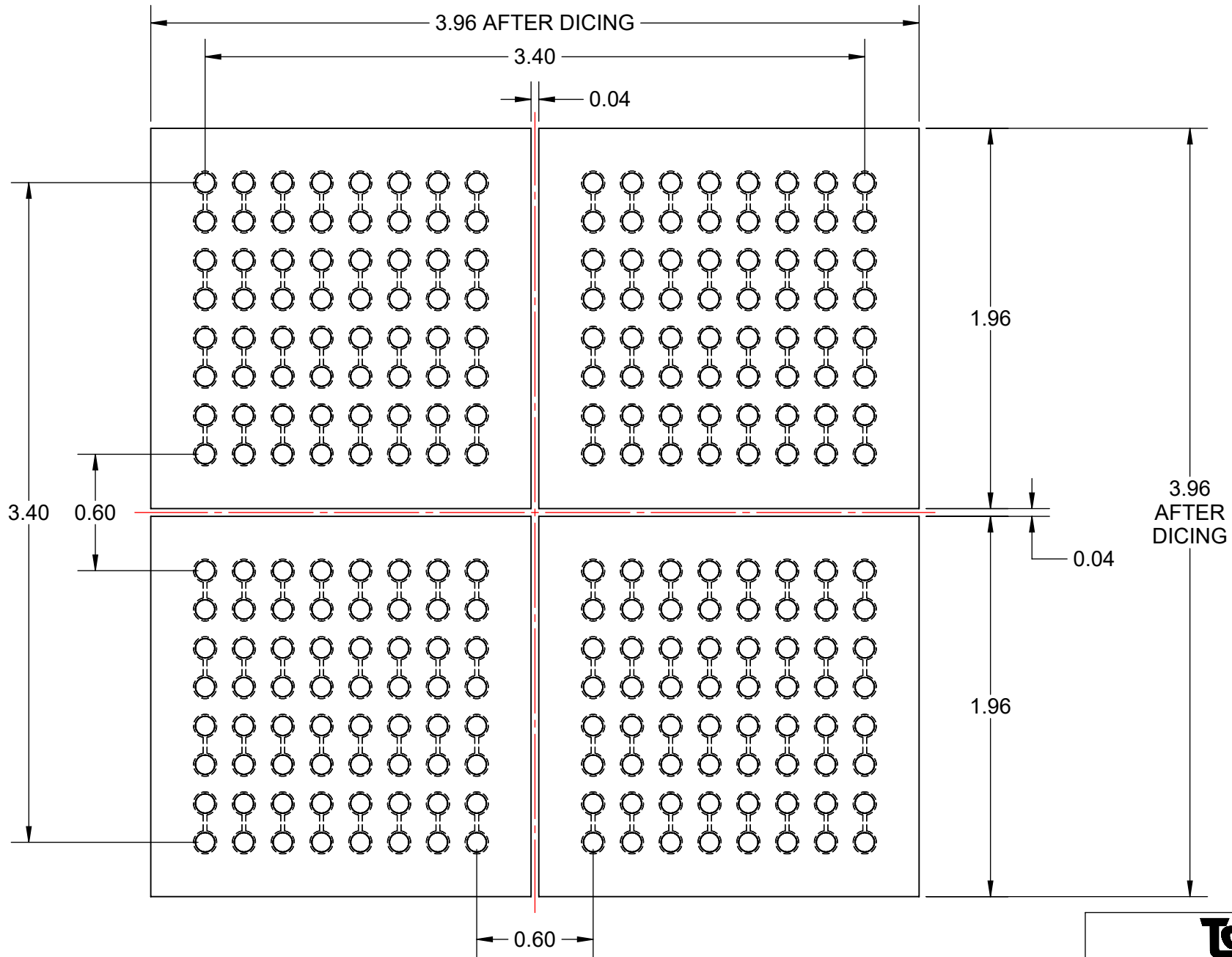

1. DIMENSIONS MM.

**TopLine®**

TITLE eWLP576T.2-DC248D  
DAISY CHAIN COPPER PAD DIE

SCALE 35:1	SIZE A	DRAWING NO. 622480	REV A
---------------	-----------	-----------------------	----------

DO NOT SCALE DRAWING

SHEET 3 OF 4

# PART NUMBERING SYSTEM

**eWLP**

**576**

**T**

**.2**

-

**DC248**

**D**

**2**

**SERIES**

eWLP = COPPER PADS WITHOUT BUMPS

**NUMBER OF PADS**

PADS	SIZE
64	2.0x2.0mm
256	4.0x4.0mm
576	6.0x6.0mm
1024	8.0x8.0mm
1600	10x10mm
2304	12x12mm
3136	14x14mm
4096	16x16mm
999	Full Wafer

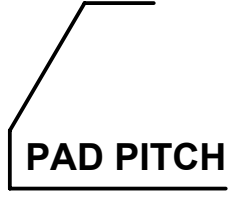

.2 = 0.2mm  
200µm



DAISY CHAIN DRAWING

**PACKAGING**

CODE	PACKAGE
W	2" TRAY
T	4" TRAY
E	TAPE & REEL
U	UV TAPE & RING
X	UNSAWN WAFER

**DIE THICKNESS**

CODE	THICKNESS
2	200µm
3	360µm
6	670µm

**PADS FACE UP/DOWN**

D = COPPER PADS DOWN  
U = COPPER PADS UP



TITLE eWLP576T.2-DC248D  
DAISY CHAIN COPPER PAD DIE

SCALE	SIZE	DRAWING NO.	REV
NONE	A	622480	A