

EXPLODED VIEW CERQUAD BOX SYSTEM

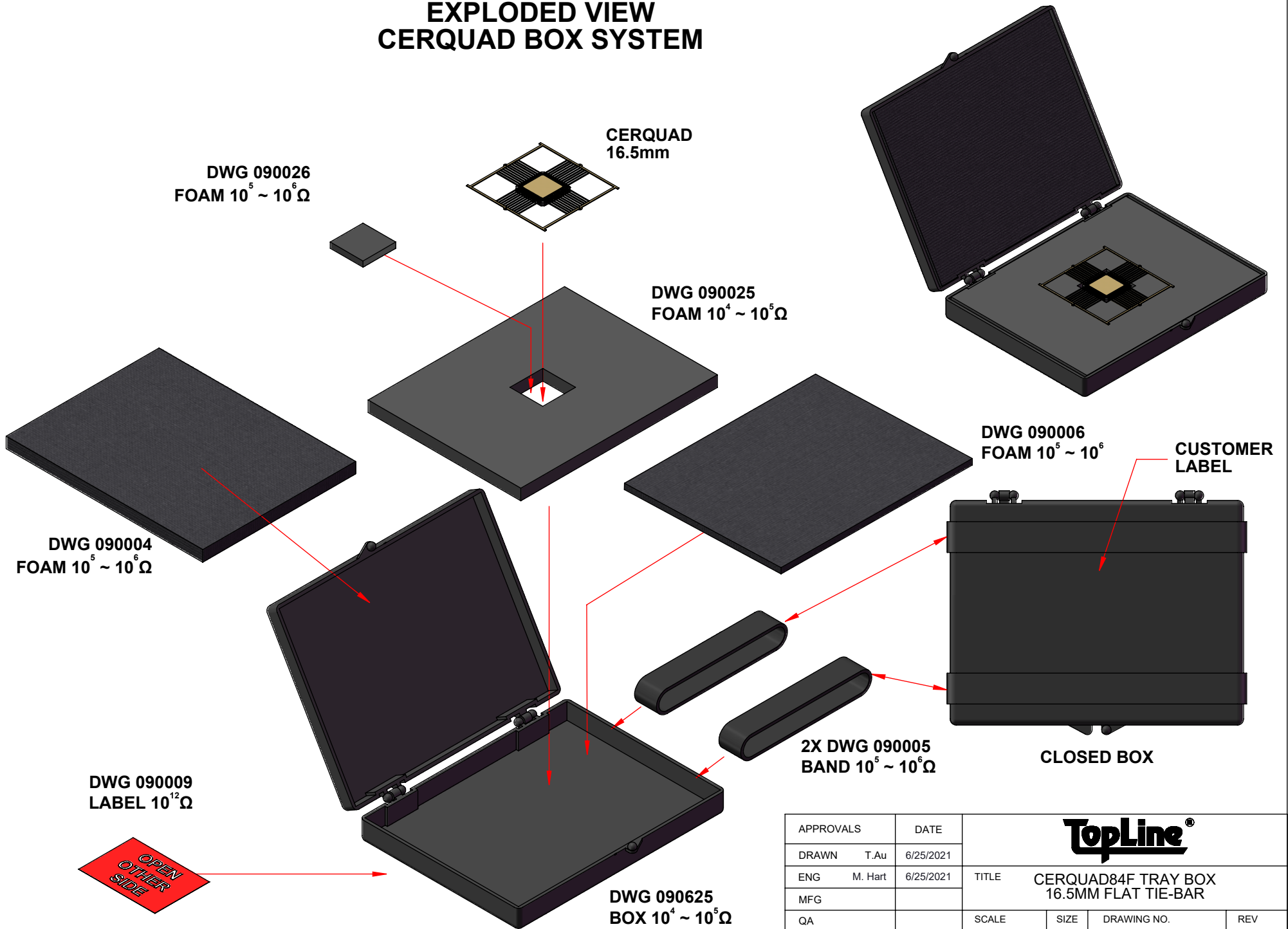

APPROVALS	DATE	TopLine®			
DRAWN T. Au	6/25/2021				
ENG M. Hart	6/25/2021	TITLE CERQUAD84F TRAY BOX 16.5MM FLAT TIE-BAR			
MFG		SCALE	SIZE	DRAWING NO.	REV
QA		1:2	A	950840	A
CUST		DO NOT SCALE DRAWING			SHEET 1 OF 9
REVISED					

TOP (OPEN)

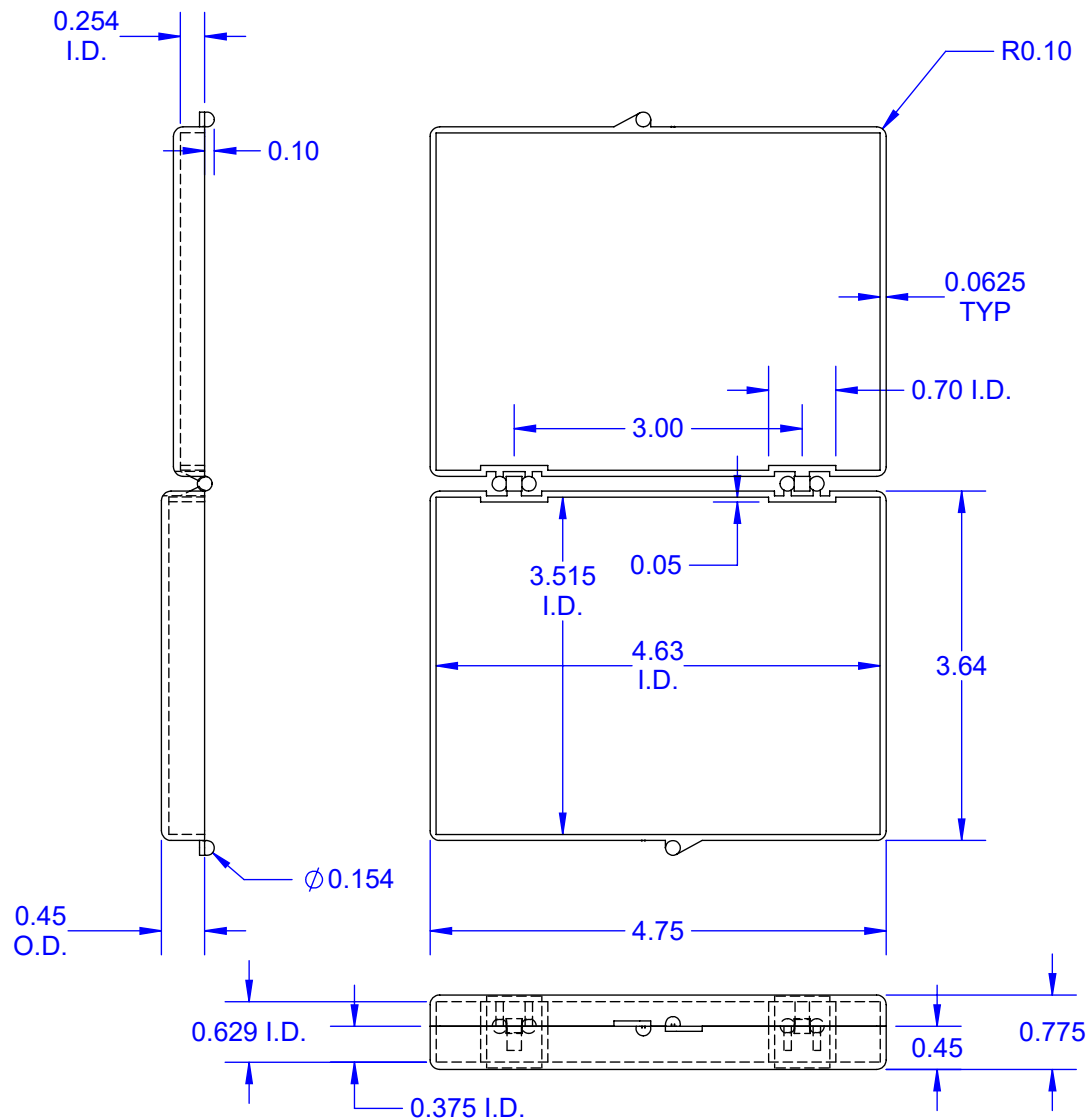

FRONT (CLOSED)

SIDE VIEW (OPEN)

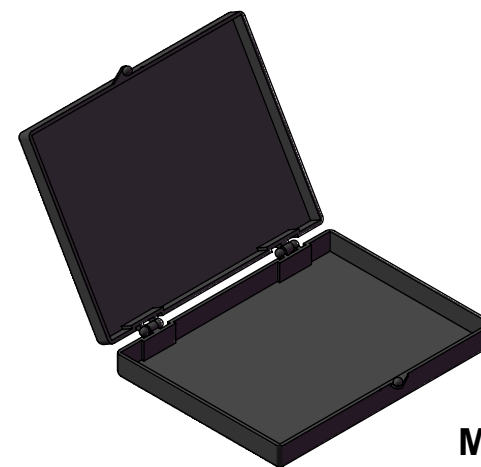
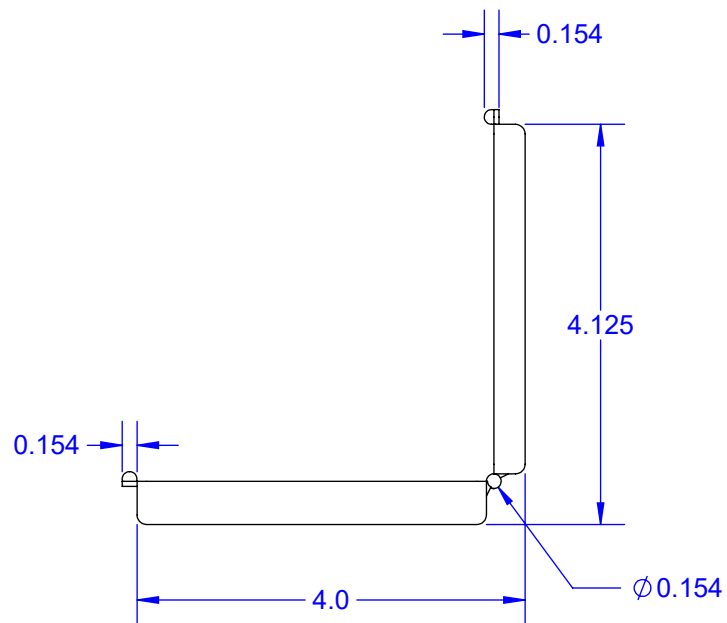

MODEL

Notes: (Unless Otherwise Specified).

- 1) SURFACE RESISTIVITY: $10^4 \sim 10^5 \Omega$.
- 2) MATERIAL: CARBON FILLED POLYPROPYLENE.
- 3) DIMENSIONS IN INCHES.

TopLine®			
TITLE		EC1-15mm EMPTY HINGE BOX	
SCALE	SIZE	DRAWING NO.	REV
1:2	A	090625	A
DO NOT SCALE DRAWING			SHEET 2 OF 9

TOP

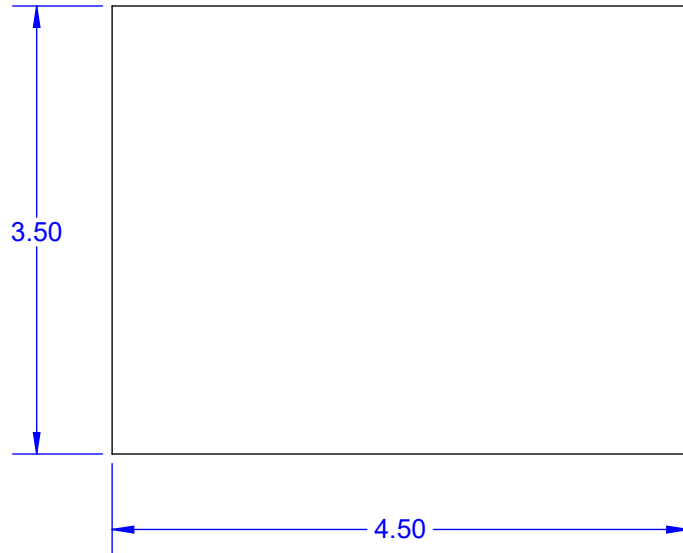

EDGE

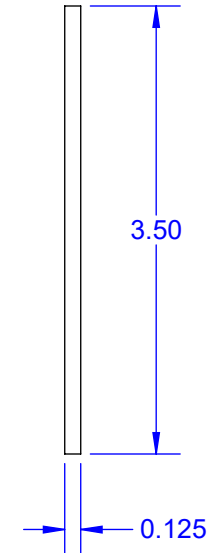

SIDE

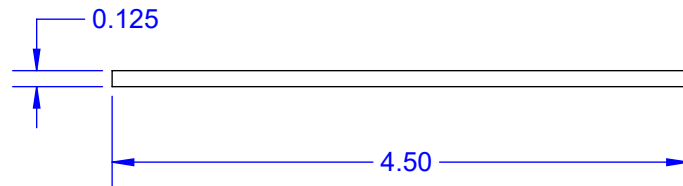

MODEL

- Notes: (Unless Otherwise Specified).
- 1) SURFACE RESISTIVITY: $10^5 \sim 10^6 \Omega$
 - 3) DENSITY 1.7 PFC Min.
 - 4) DIMENSIONS IN INCHES.

TopLine®			
TITLE EC1-FOAM-SOFT-.125-A LOW DENSITY FOAM			
SCALE	SIZE	DRAWING NO.	REV
1:1.5	A	090006	A
DO NOT SCALE DRAWING			SHEET 3 OF 9

TOP

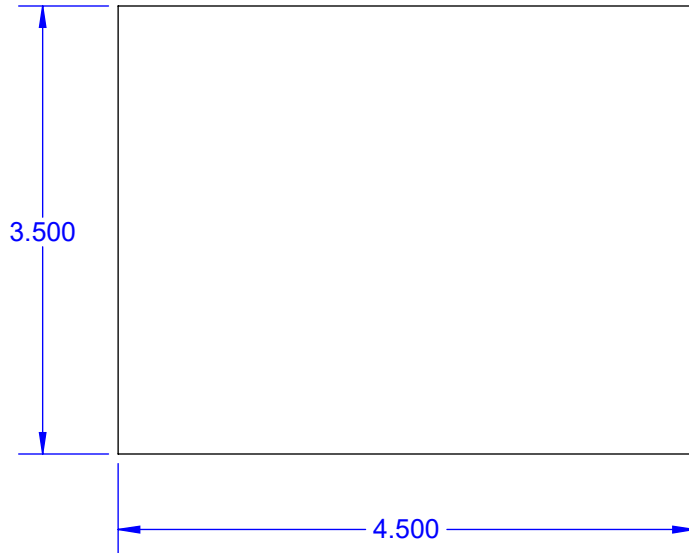

EDGE

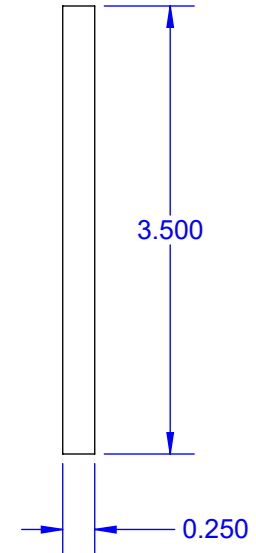

SIDE

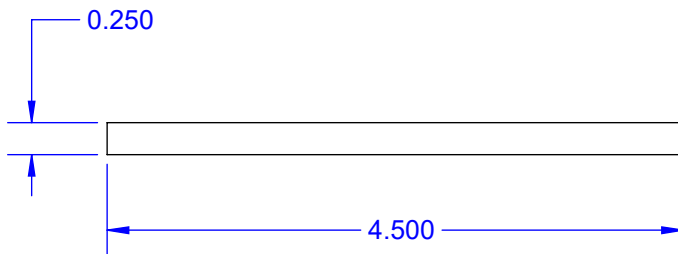

MODEL

Notes: (Unless Otherwise Specified).

- 1) SURFACE RESISTIVITY: 10^3 TO $10^6 \Omega$ PER SQUARE.
- 2) DENSE CONDUCTIVE FOAM.
- 3) DENSITY 2.0 PFC Min.
- 4) DIMENSIONS INCHES.

TopLine[®]			
TITLE		EC1-FOAM-FIRM-B HIGH DENSITY FOAM	
SCALE	SIZE	DRAWING NO.	REV
1:1.5	A	090004	A
DO NOT SCALE DRAWING			SHEET 4 OF 9

TOP

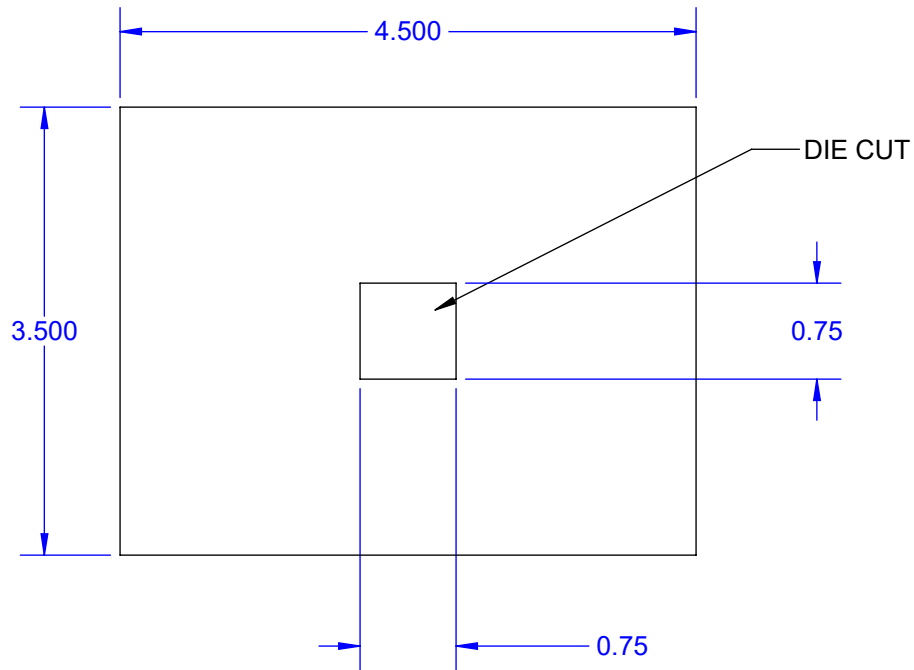

EDGE

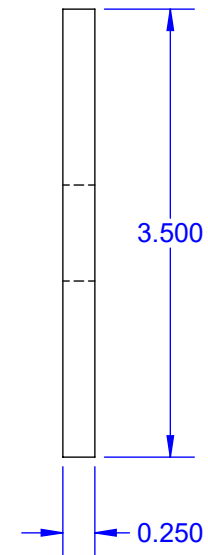

SIDE

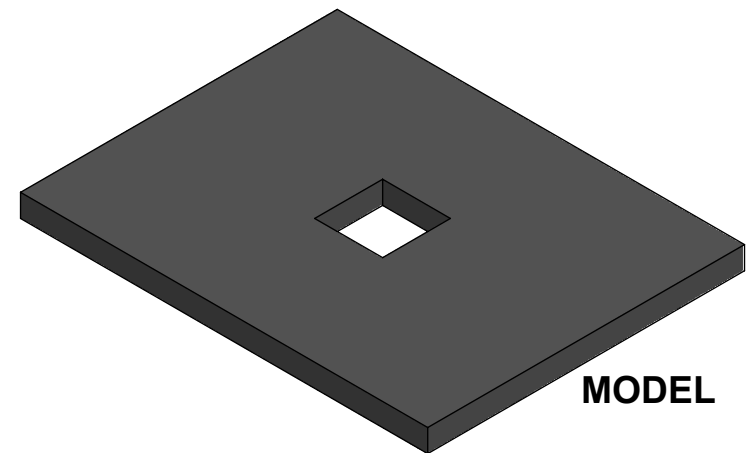
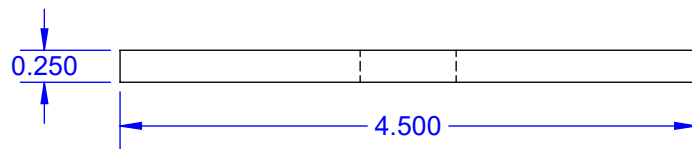

MODEL

Notes: (Unless Otherwise Specified).

- 1) SURFACE RESISTIVITY: $10^3 \Omega$ TO $10^6 \Omega$ PER SQUARE.
- 2) DENSE CONDUCTIVE FOAM.
- 3) DENSITY 2.0 PFC Min.
- 4) DIMENSIONS INCH (mm).

TopLine[®]

TITLE		EC1-FOAM INSERT-B HIGH DENSITY FOAM	
SCALE	SIZE	DRAWING NO.	REV
2:3	A	090025	A
DO NOT SCALE DRAWING		SHEET 5 OF 9	

TOP

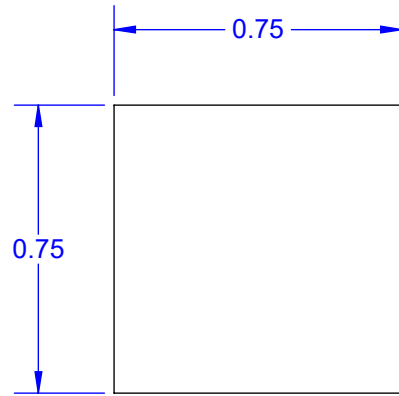

EDGE

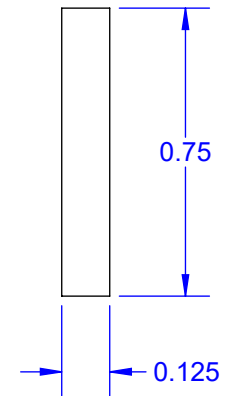

SIDE

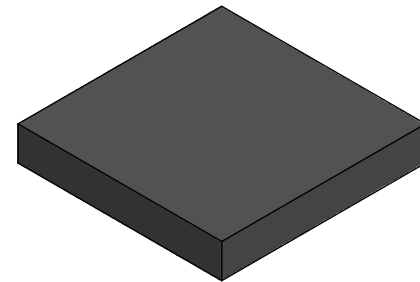
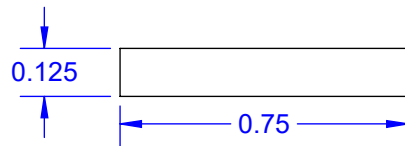

MODEL

Notes: (Unless Otherwise Specified).

- 1) SURFACE RESISTIVITY: $10^3 \Omega$ TO $10^6 \Omega$ PER SQUARE.
- 2) SOFT CONDUCTIVE FOAM.
- 3) DENSITY 1.7 PFC Min.
- 4) DIMENSIONS INCHES.

TopLine[®]			
TITLE		FOAM-SOFT-.75-A LOW DENSITY FOAM	
SCALE	SIZE	DRAWING NO.	REV
2:1	A	090026	A
DO NOT SCALE DRAWING			SHEET 6 OF 9

TOP

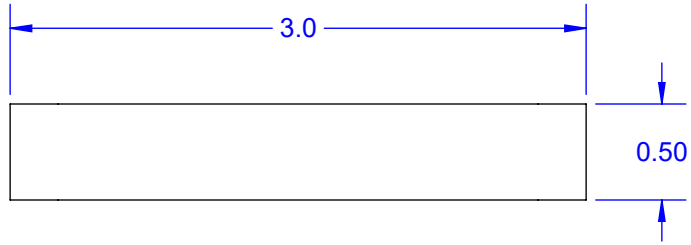

EDGE

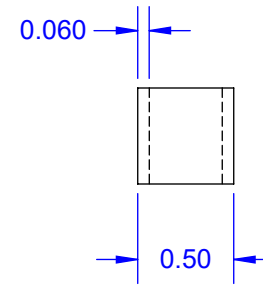

SIDE

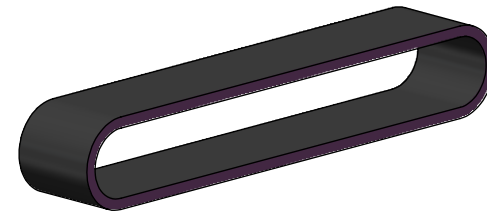
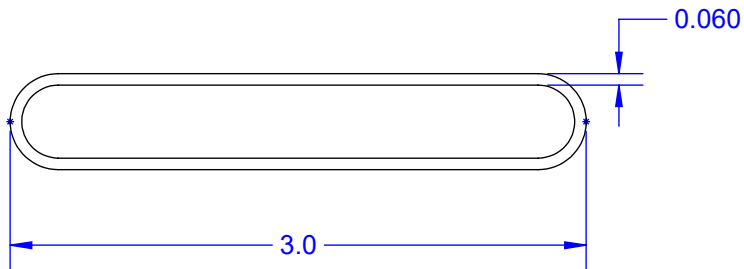

MODEL

Notes: (Unless Otherwise Specified).

1) SURFACE RESISTIVITY: $10^5 \sim 10^6$.

2) DIMENSIONS IN INCHES (RESTING POSITION).

TopLine®			
TITLE		RUBBER BAND-3.0-C BLACK CONDUCTIVE	
SCALE	SIZE	DRAWING NO.	REV
1:1	A	090005	A
DO NOT SCALE DRAWING			SHEET 7 OF 9

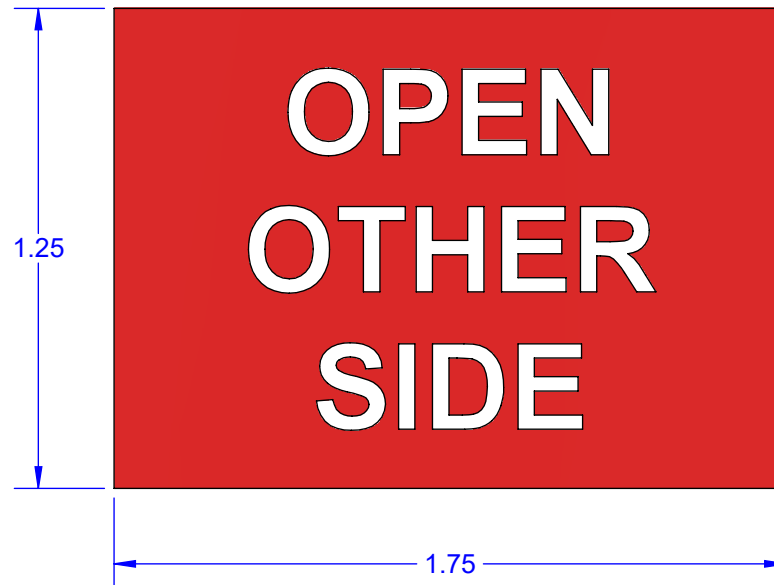

Notes: (Unless Otherwise Specified).

1. DIMENSIONS INCHES.
2. MATERIAL: PAPER LABEL WITH ADHESIVE.
3. COLOR: RED.
4. PURPOSE: IDENTIFY BOTTOM OF HINGE BOX.

TopLine®			
TITLE		LABEL FOR BOTTOM OF HINGE BOX	
SCALE	SIZE	DRAWING NO.	REV
2:1	A	090009	A
DO NOT SCALE DRAWING			SHEET 8 OF 9

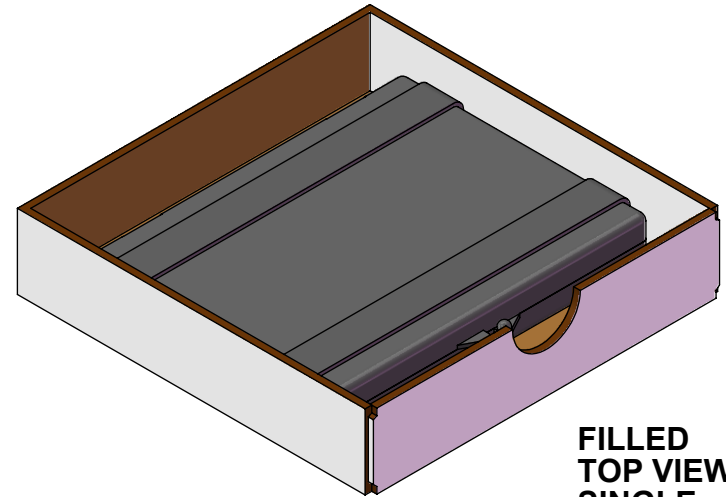
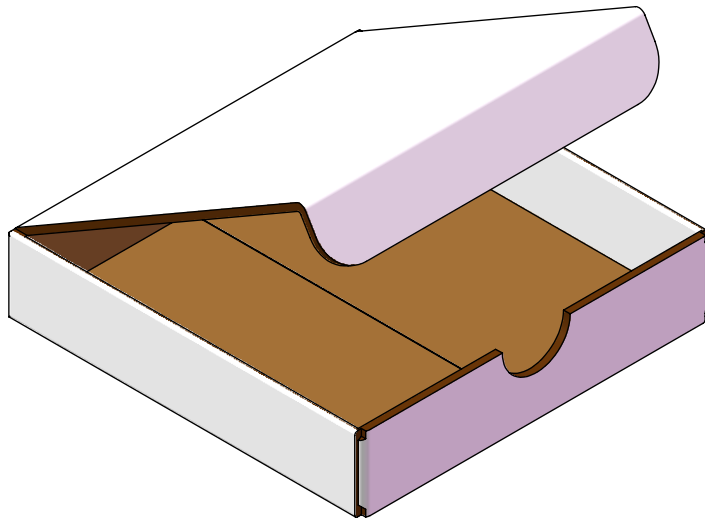
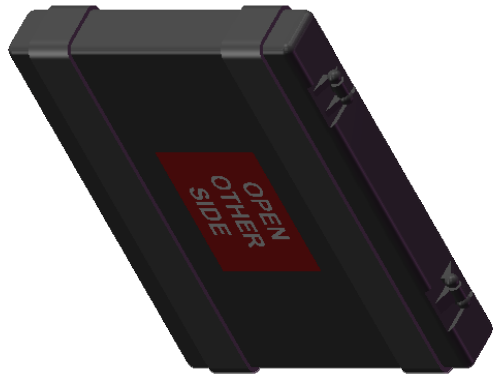

**FILLED
TOP VIEW
SINGLE**

Notes: (Unless Otherwise Specified).

1. DIMENSIONS INCHES.
2. MEASUREMENT INCLUDES RUBBER BANDS.
3. BOX SIZE SUBJECT TO CHANGE.

TopLine®

TITLE CCGA TRAY BOX CARRIER
CARTON

SCALE 1:2	SIZE A	DRAWING NO. 900001	REV A
--------------	-----------	-----------------------	----------

DO NOT SCALE DRAWING

SHEET 9 OF 9