

TOP VIEW

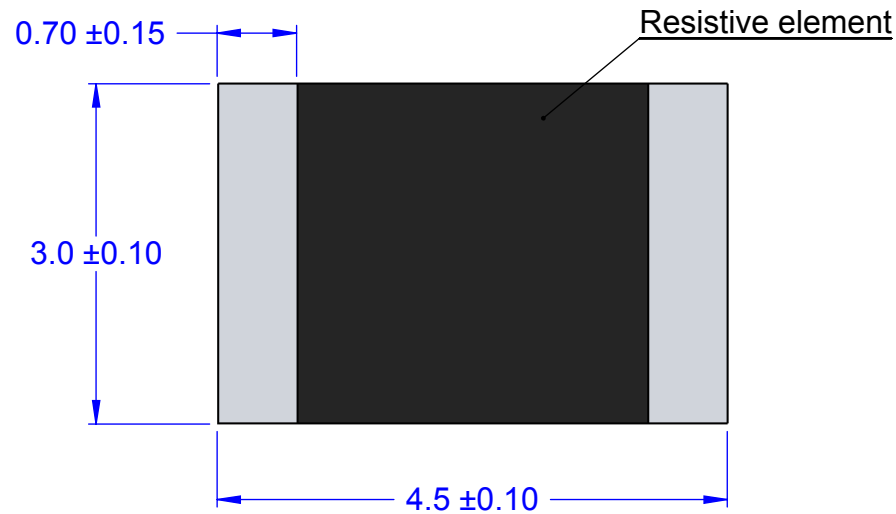

RECOMMENDED PCB PATTERN

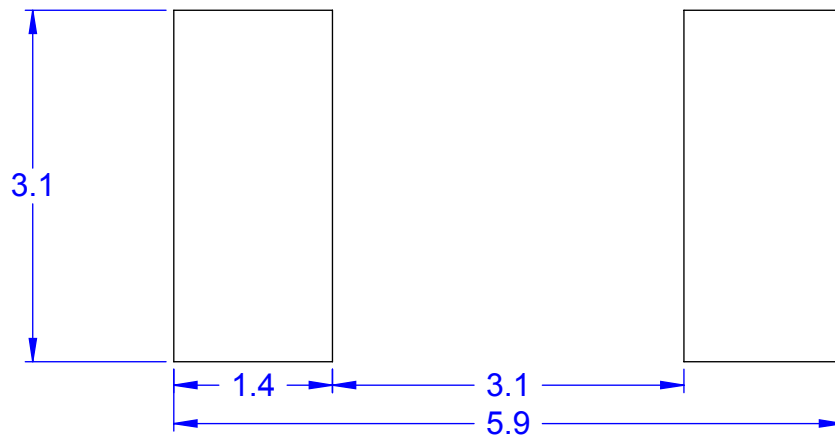

PCB DIMENSIONS ARE PRESENTED ONLY AS A GUIDELINE. DESIGNERS SHOULD USE THEIR OWN KNOWLEDGE BASE WHEN DESIGNING THE PCB.

STRUCTURE

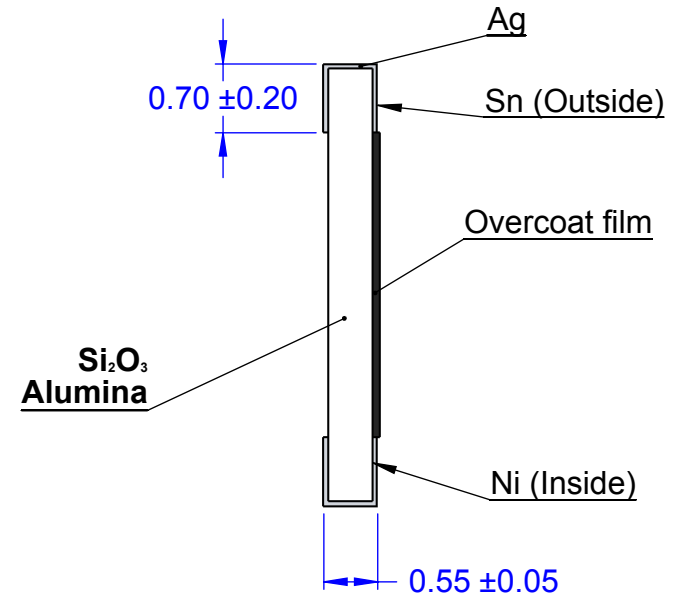

NOTES:

1. DIMENSIONS IN mm.
2. TERMINATION: Tin (Sn).
3. Pb-FREE AND HALOGEN FREE.

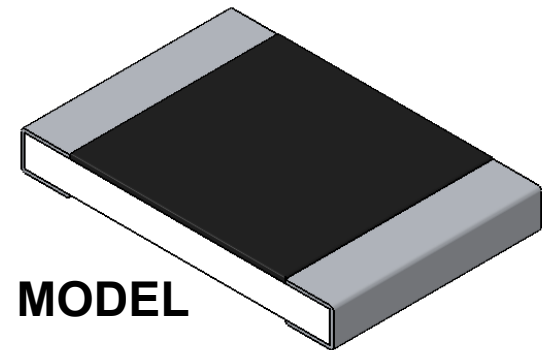

MODEL

APPROVALS	DATE	TopLine®			
DRAWN T. Au	08/03/12				
ENG M. Hart	08/03/12	TITLE SR1812 SMT RESISTOR			
MFG		SCALE	SIZE A	DRAWING NO. 121812	REV A
QA					
CUST		DO NOT SCALE DRAWING			SHEET 1 OF 2
REVISED					

W12P4 CARRIER TAPE DIMENSION

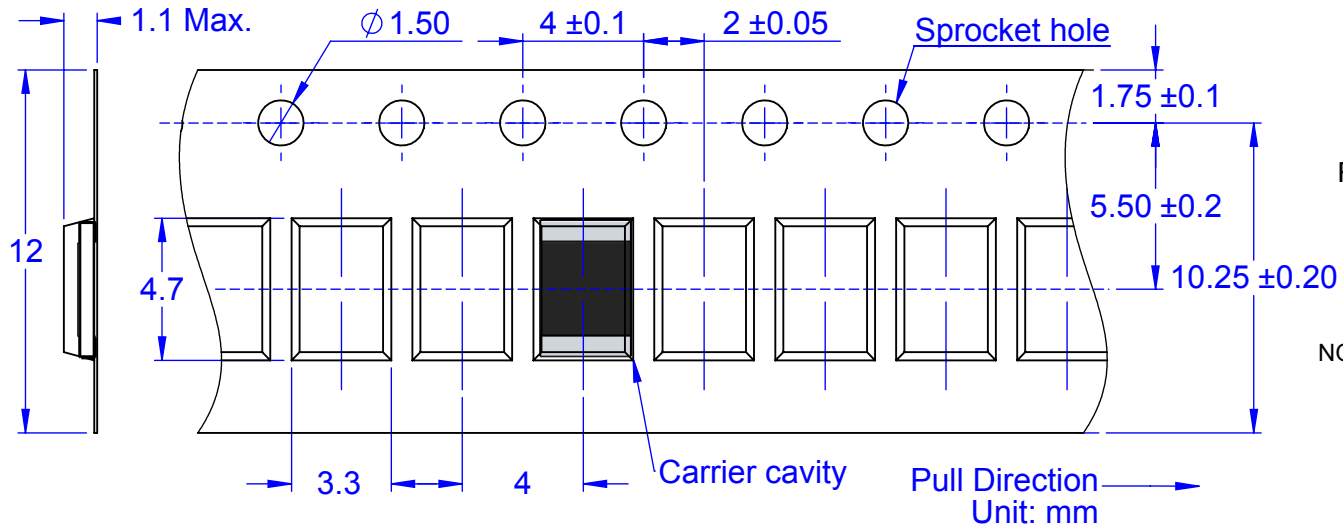

PART NUMBER SYSTEM

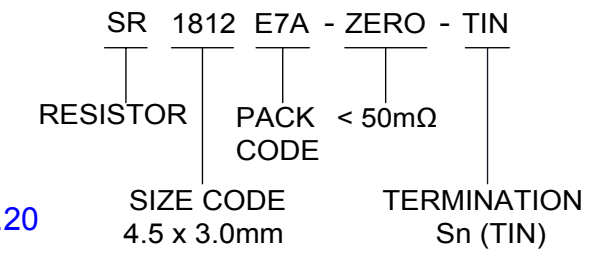

NOTE: For dummy resistor replace ZERO with blank

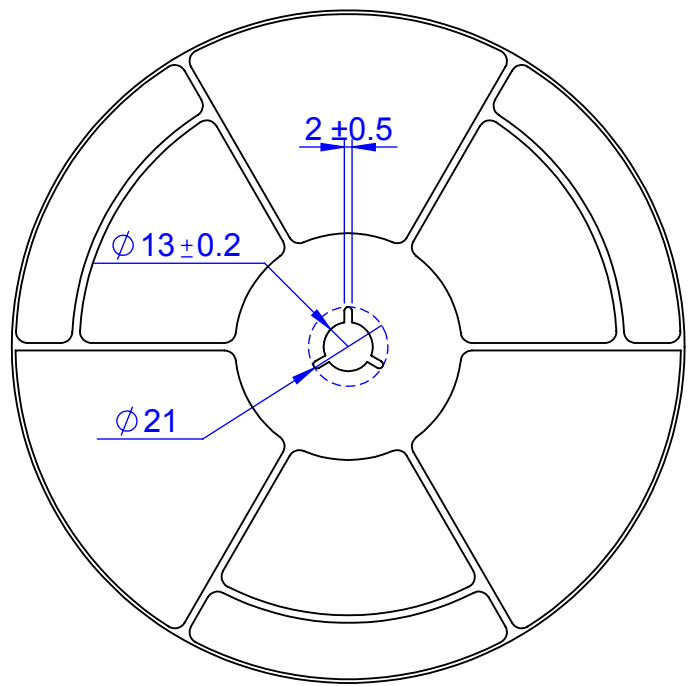

REEL DIMENSIONS

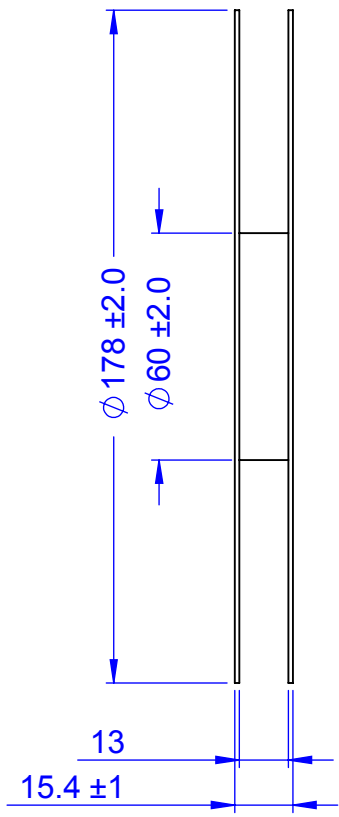

PACK CODE

*CODE	QTY	PACKAGE
E7A	4,000	REEL
E4A	500	REEL

APPROVALS	DATE	TopLine®			
DRAWN T. Au	08/03/12				
ENG M. Hart	08/03/12	TITLE SR1812 SMT RESISTOR			
MFG		SCALE	SIZE A	DRAWING NO.	REV
QA				121812	A
CUST		DO NOT SCALE DRAWING			SHEET 2 OF 2
REVISED					