

**TOP VIEW
SHOWN WITHOUT LID**

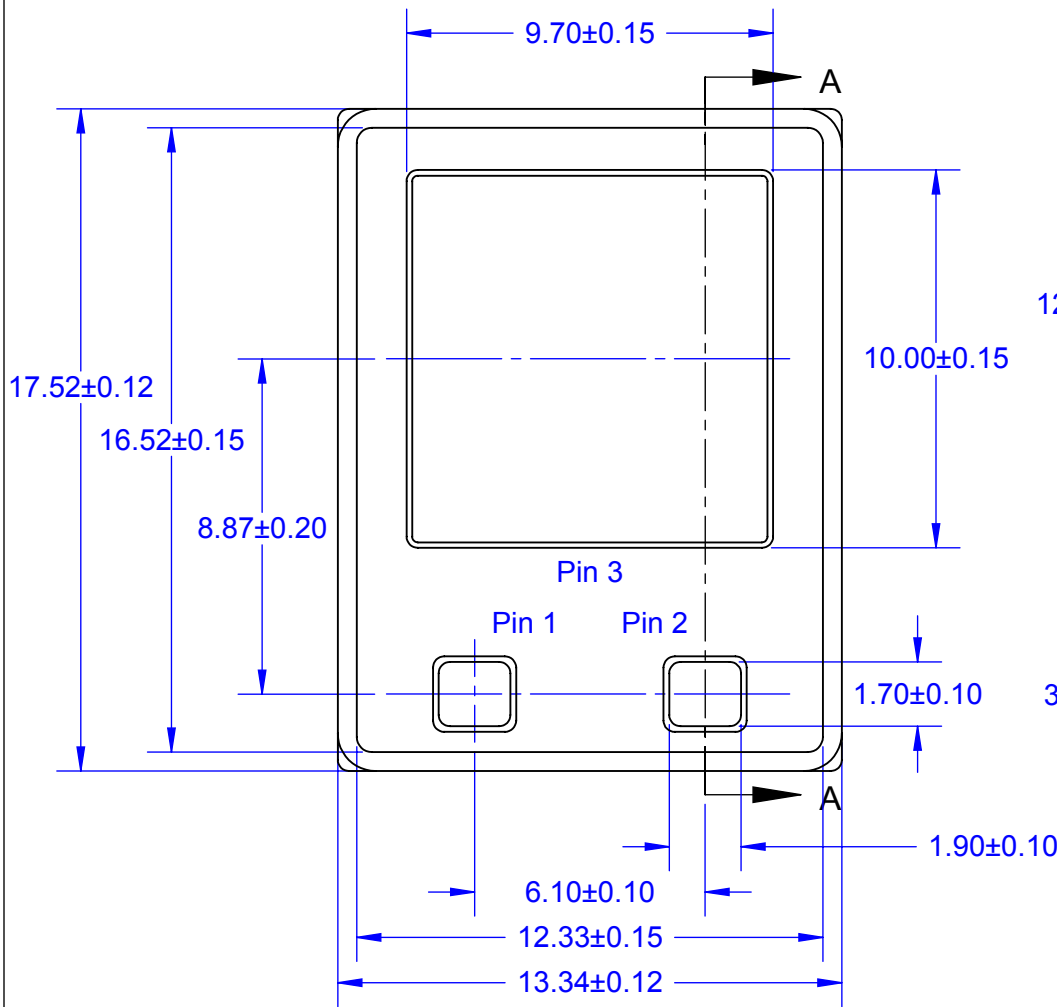

SIDE VIEW

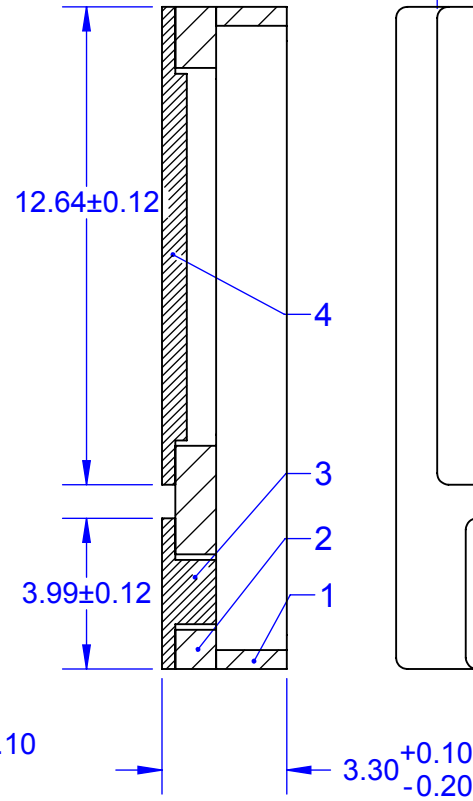

BOTTOM VIEW

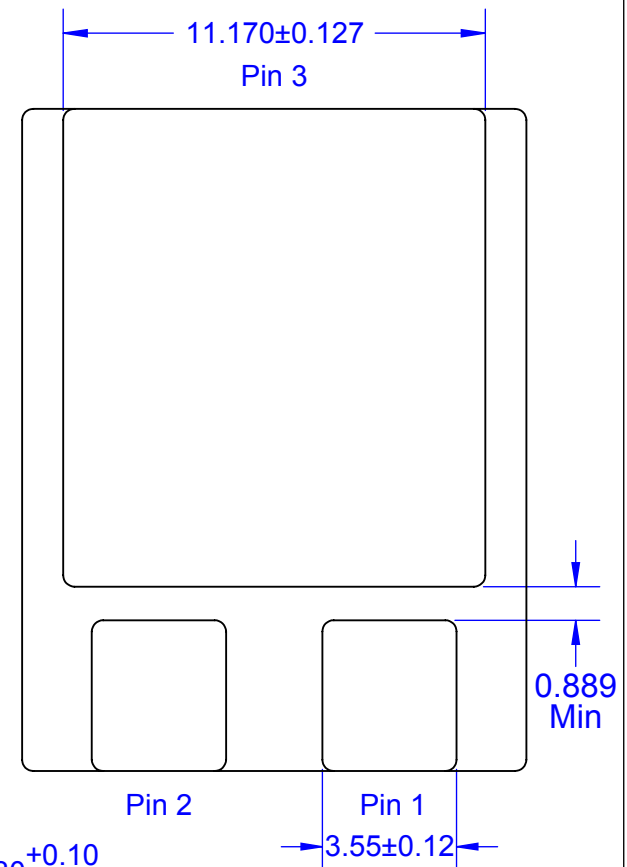

Part Number Table

Part Number	JEDEC	Daisy Chain	Dummy Die	Attached Lid	DWG Number
SMD2-N	TO-276AC	NO	NO	NO	800200
SMD2-ISO	TO-276AC	NO	NO	YES	800201
SMD2-DC123	TO-276AC	YES	NO	YES	800202
SMD2-DC123D	TO-276AC	YES	YES	YES	800203
SMD2	TO-276AC	NO	NO	YES	800209
LID SMD2	TO-276AC	-	-	Unattached	202000

APPROVALS	DATE				
DRAWN T.Au	08/17/14				
ENG M. Hart	08/17/14	TITLE SMD2 (TO-276AC) POWER PACKAGE			
MFG		SCALE 5:1	SIZE A	DRAWING NO. 800200	REV A
QA					
CUST					
REVISED		DO NOT SCALE DRAWING			SHEET 1 OF 4

**INTERNAL WIRING CIRCUIT (JUMPER)
DAISY CHAIN PART NUMBER SUFFIX
TOP VIEW**

OPTIONAL DUMMY DIE

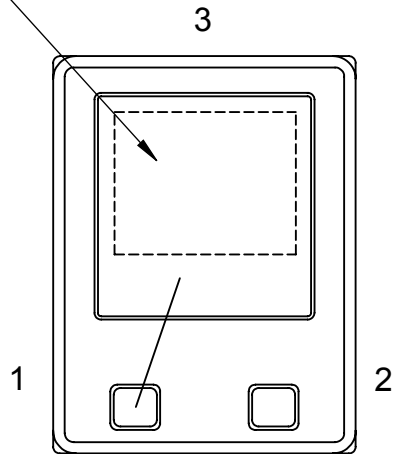

**DC13
WITH LID
ATTACHED**

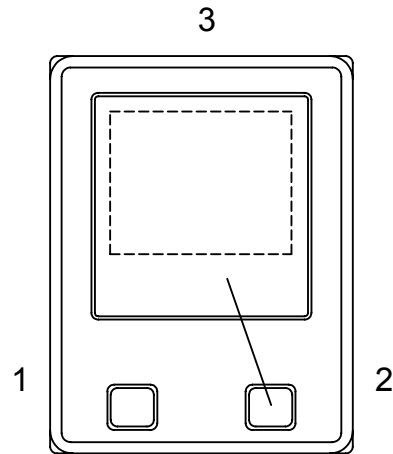

**DC23
WITH LID
ATTACHED**

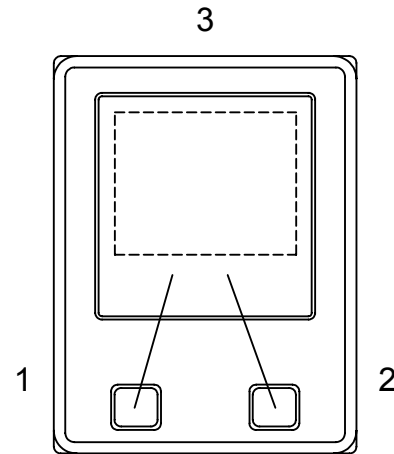

**DC123
WITH LID
ATTACHED**

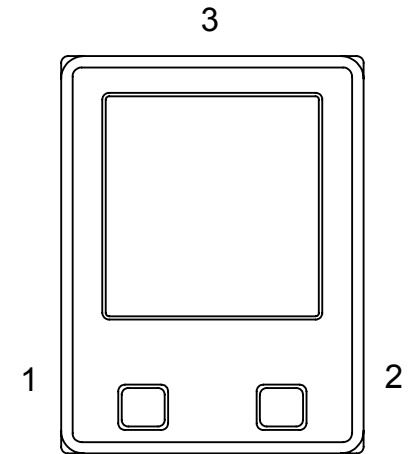

**OPTION-N
OPEN CAVITY
WITHOUT LID ATTACHED**

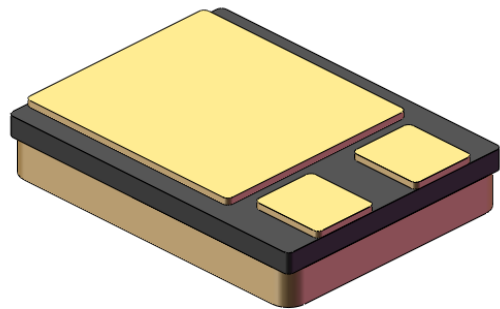

**BOTTOM
VIEW OF TERMINALS**

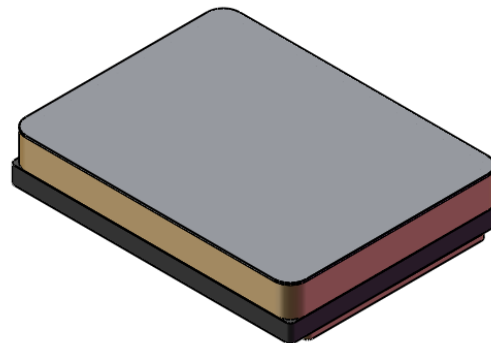

**TOP
LID ATTACHED**

TopLine®			
TITLE		SMD2 (TO-276AC) POWER PACKAGE	
SCALE	SIZE	DRAWING NO.	REV
3:1	A	800200	A
DO NOT SCALE DRAWING			SHEET 2 OF 4

SCHEMATIC EQUIVALENT INTERNAL CIRCUIT

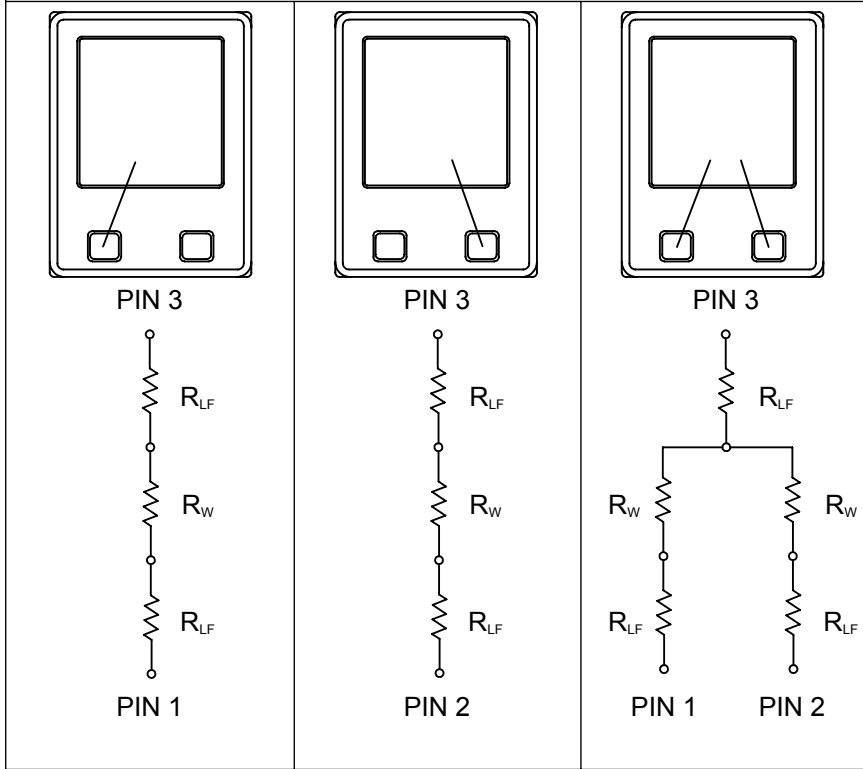

R_W = GOLD WIRE-BOND.
 R_{LF} = LEAD FRAME.

ELECTRICAL RESISTANCE MILLIOHM (DC) MAX			
CIRCUIT	PIN 1 TO 3	PIN 2 TO 3	PIN 1 TO 2
DC13	< 100 m Ω	--	--
DC23	--	< 100 m Ω	--
DC123	< 100 m Ω	< 100 m Ω	< 200 m Ω

BILL OF MATERIAL		
ITEM	COMPONENT NAME	RAW MATERIAL
1	FRAME	KOVAR/4J29
2	CERAMIC	AL203 90% BLACK
3	BIG PAD	W85CU15
4	TWO SMALL PADS	KOVAR

NOTES:

GENERAL SPECIFICATIONS COMPLY WITH MIL-STD-750E AND SCREENED PER MIL-PRF-38354.

1. MATERIAL: SEE BOM.
2. FINAL FINISH: 50-MICRO-INCH GOLD OVER 100-MICRO-INCH (MIN) NICKEL.
3. PARTS EQUAL OR EXCEED 10^{10} OHMS ISOLATION TEST WITH 500VDC PINS TO CASE.
4. BREAKDOWN VOLTAGE: 1000V BREAKDOWN VOLTAGE TEST WITH NORMAL TESTING CONDITIONS (PADS AND CASE).

TopLine[®]			
TITLE		SMD2 (TO-276AC) POWER PACKAGE	
SCALE	SIZE	DRAWING NO.	REV
2:1	A	800200	A
DO NOT SCALE DRAWING			SHEET 3 OF 4

PART NUMBERING SYSTEM

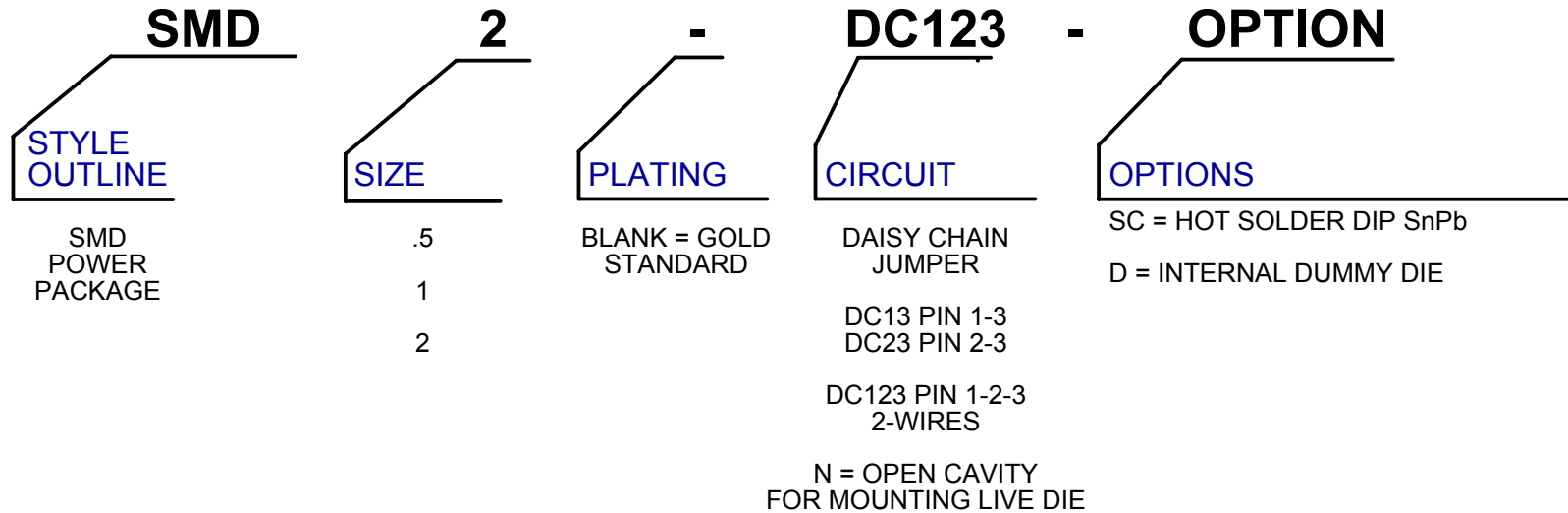

PART NUMBER	SHORTED PINS	NOTES	SEALED LID	DUMMY DIE
SMD2	N/A	DUMMY	YES	N/A
SMD2-D	N/A	DUMMY	YES	YES
SMD2-N	NONE	ISOLATED	NO	NO
SMD2-DC13	1 ~ 3	DAISY CHAIN	YES	NO
SMD2-DC13D	1 ~ 3	DAISY CHAIN	YES	YES
SMD2-DC23	2 ~ 3	DAISY CHAIN	YES	NO
SMD2-DC23D	2 ~ 3	DAISY CHAIN	YES	YES
SMD2-DC123	1 ~ 2 ~ 3	DAISY CHAIN	YES	NO
SMD2-DC123D	1 ~ 2 ~ 3	DAISY CHAIN	YES	YES

TopLine®			
TITLE SMD2 (TO-276AC) POWER PACKAGE			
SCALE 1:1	SIZE A	DRAWING NO. 800200	REV A
DO NOT SCALE DRAWING			SHEET 4 OF 4