

TOP VIEW

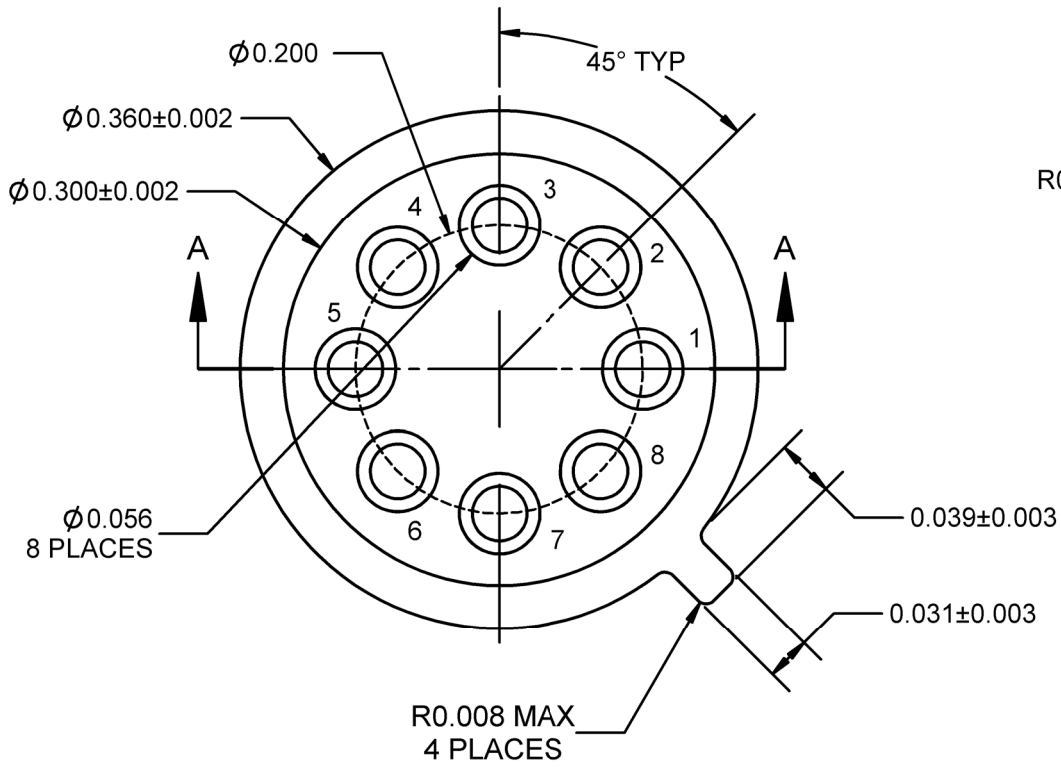

SECTION VIEW A-A

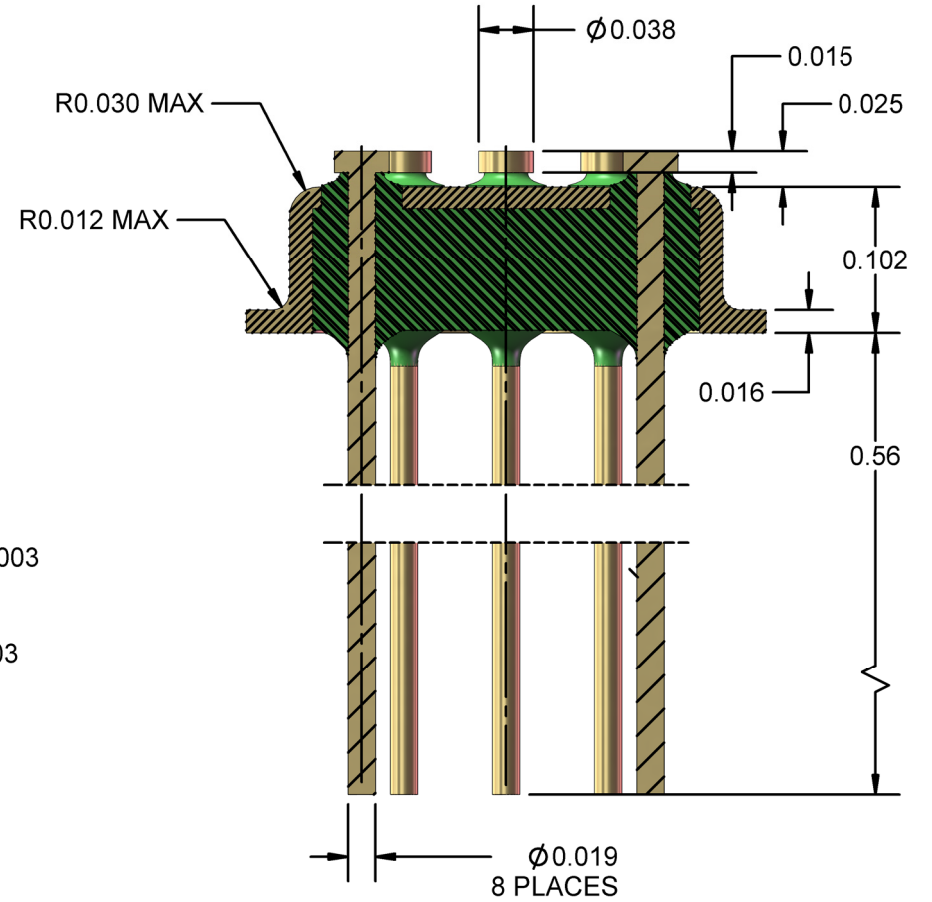

SECTION A-A
SCALE 7.5 : 1



NOTES:

1. DIMENSIONS in INCH (Unless Otherwise Specified).
2. BODY KOVAR ASTM F45 ALLOY 42.
3. LEADS KOVAR ASTM F15.
4. GLASS 7052 OR EQUIVALENT.
5. PLATING: Ni 100~300 Micro-inch
Au 50 Micro-inch MIN

APPROVALS	DATE	TopLine			
DRAWN T.Au	6/16/2018				
ENG M. Hart	6/16/2018	TITLE TO-5 HEADER 8L NAIL HEAD ISOLATED			
MFG		SCALE	SIZE	DRAWING NO.	REV
QA		7.5:1	A	140508	A
CUST		DO NOT SCALE DRAWING			SHEET 1 OF 1
REVISED					