

Notes: (Unless Otherwise Specified).

- 1) DIMENSIONS: MM [INCH].
- 2) FLAT LEADS ON KOVAR OR ALLOY 42 TIE BAR.
- 3) ALL EXPOSED METAL GOLD PLATED (Au).
60 micro-inch thick gold.
- 4) GROUND PAD ELECTRICALLY CONNECTED TO HEATSINK AND S/R

APPROVALS	DATE	TopLine®			
DRAWN T.Au	4/5/2023				
ENG M. Hart	4/5/2023	TITLE CQFP64F19.7B-HS-N228 64L P=0.5mm			
MFG		SCALE	SIZE	DRAWING NO.	REV
QA		5:1	A	166400	A
CUST		DO NOT SCALE DRAWING			SHEET 1 OF 6
REVISED					

BOTTOM SIDE

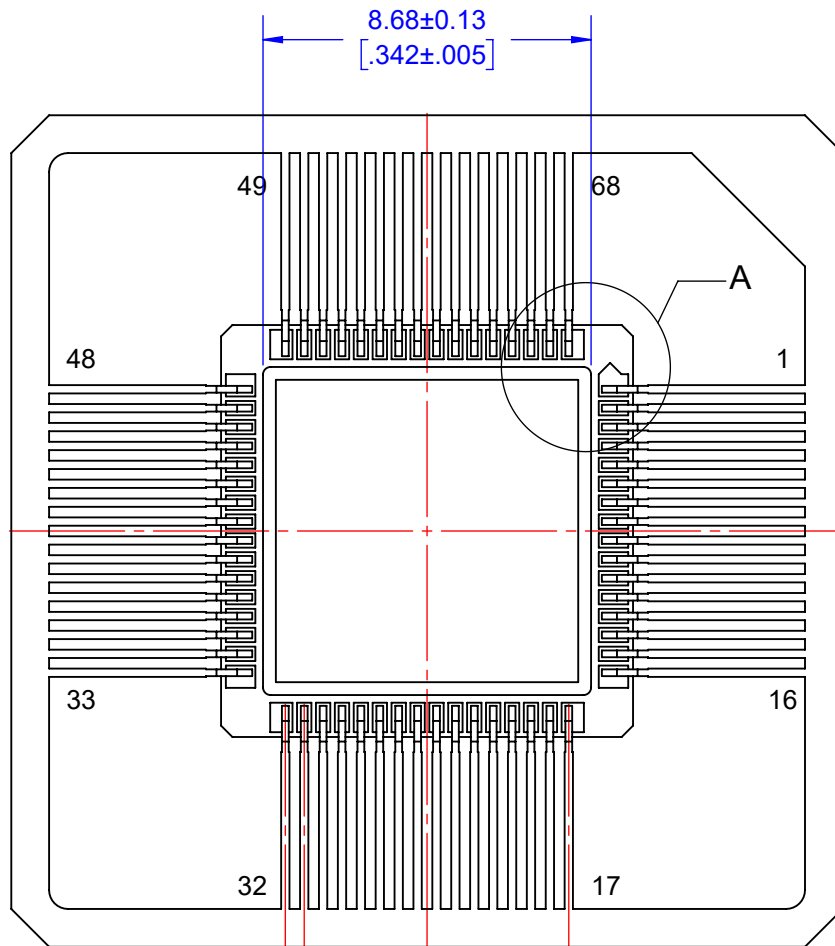

0.50 ± 0.05
 $[\.0197 \pm 0.003]$
 (AT TIE BAR)

7.50 ± 0.13
 $[\.295 \pm .005]$

$P = 0.50 \times 15$
 $[P = .020 \times 15]$
 (AT TIE BAR)

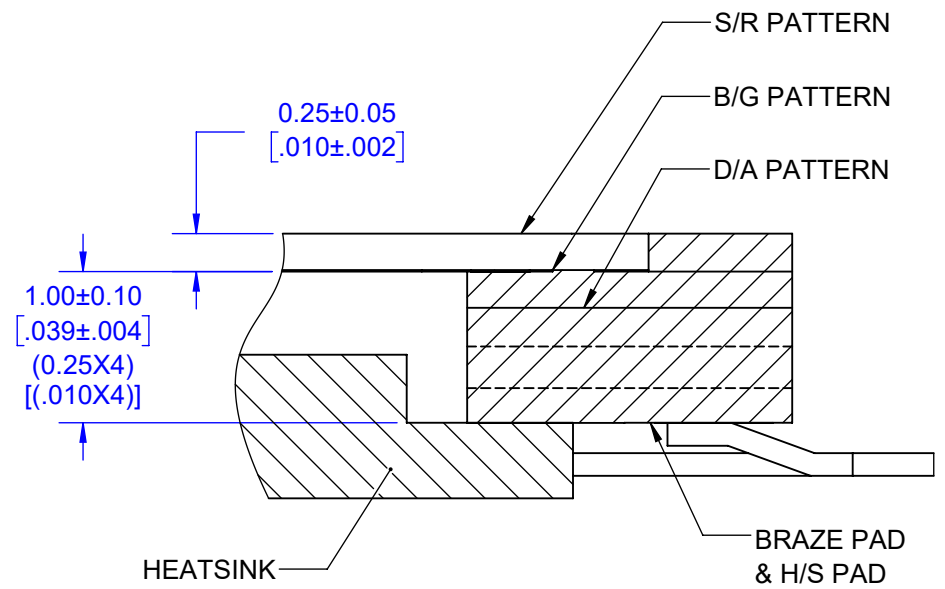

PACKAGE LAYERS

- NOTES:
- GOLD PLATE 3.05~5.72µm MIN [120~225 µINCH]
2.0µm MIN [80 µINCH MIN] NICKEL.
 - GND PAD TO BE ELECTRICALLY CONNECTED TO H/S & S/R.

TopLine®			
TITLE CQFP64F19.7B-HS-N228 64L P=0.5mm			
SCALE 4:1	SIZE A	DRAWING NO. 166400	REV A
DO NOT SCALE DRAWING		SHEET 2 OF 6	

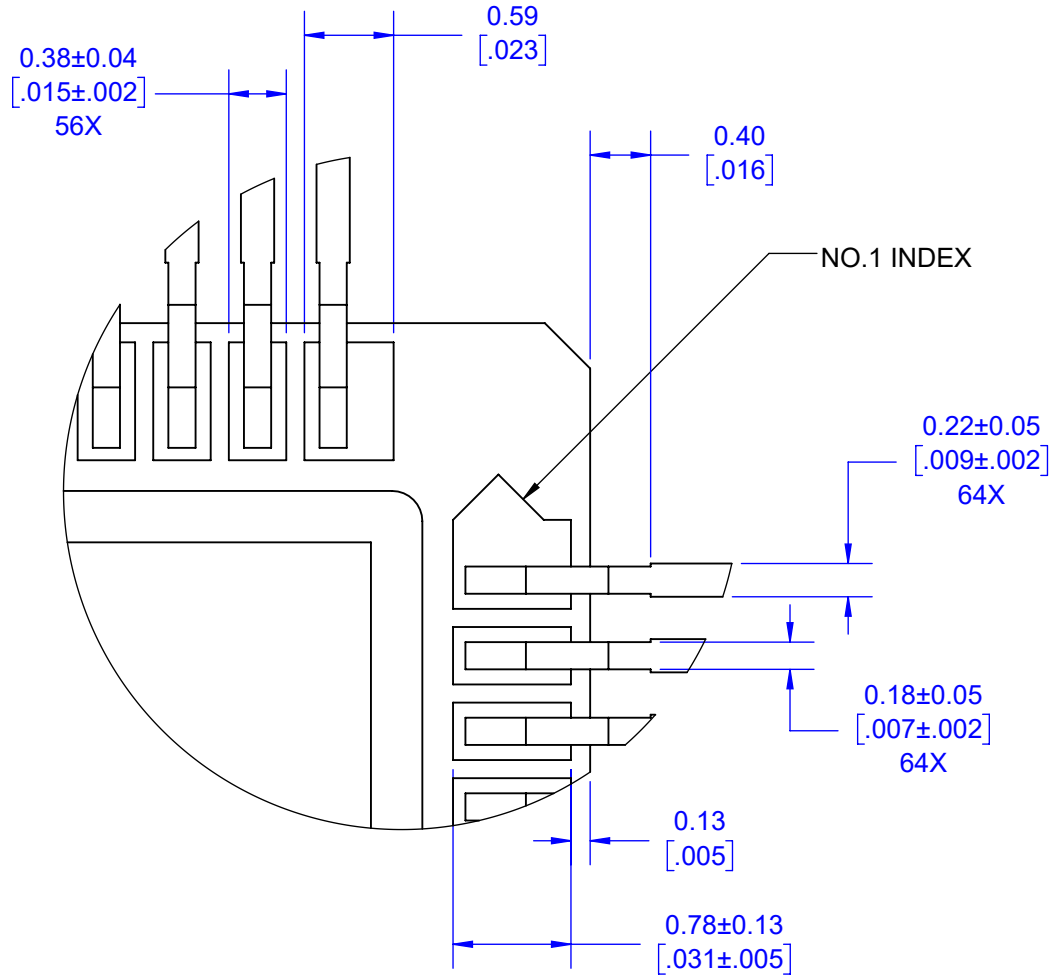

DETAIL A
SCALE 20 : 1

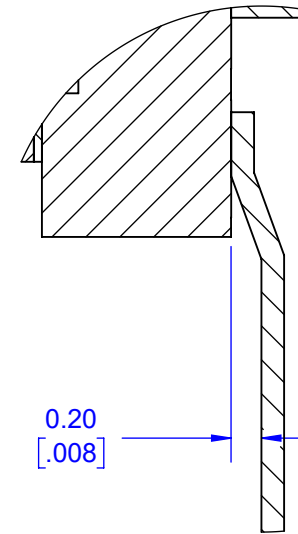

DETAIL B
SCALE 20 : 1

TopLine®			
TITLE CQFP64F19.7B-HS-N228 64L P=0.5mm			
SCALE 20:1	SIZE A	DRAWING NO. 166400	REV A
DO NOT SCALE DRAWING			SHEET 3 OF 6

BONDING DIAGRAM

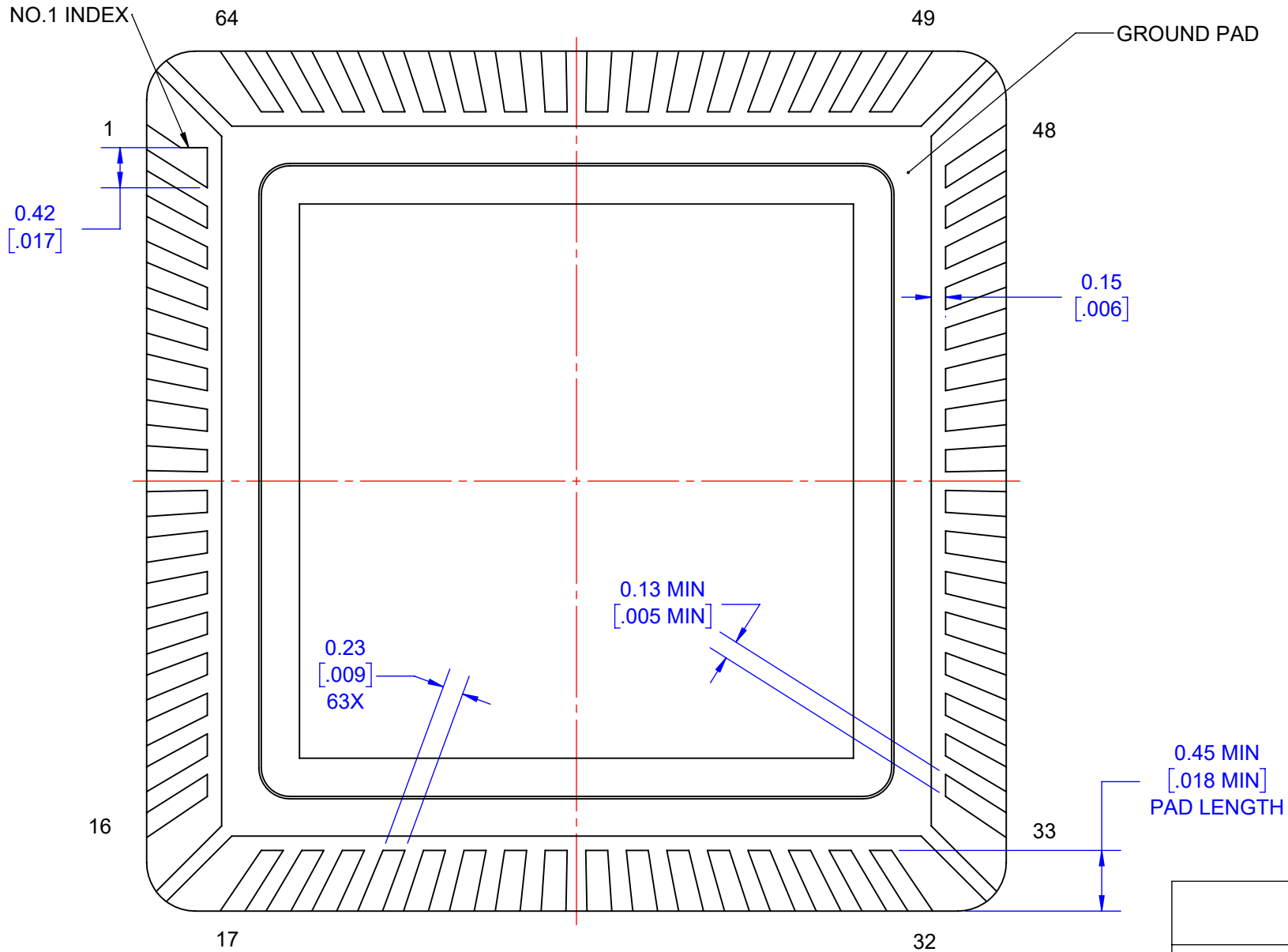

TopLine[®]			
TITLE CQFP64F19.7B-HS-N228 64L P=0.5mm			
SCALE	SIZE	DRAWING NO.	REV
16:1	A	166400	A
DO NOT SCALE DRAWING			SHEET 4 OF 6

**MODELS
OPEN PACKAGE
WITHOUT LID**

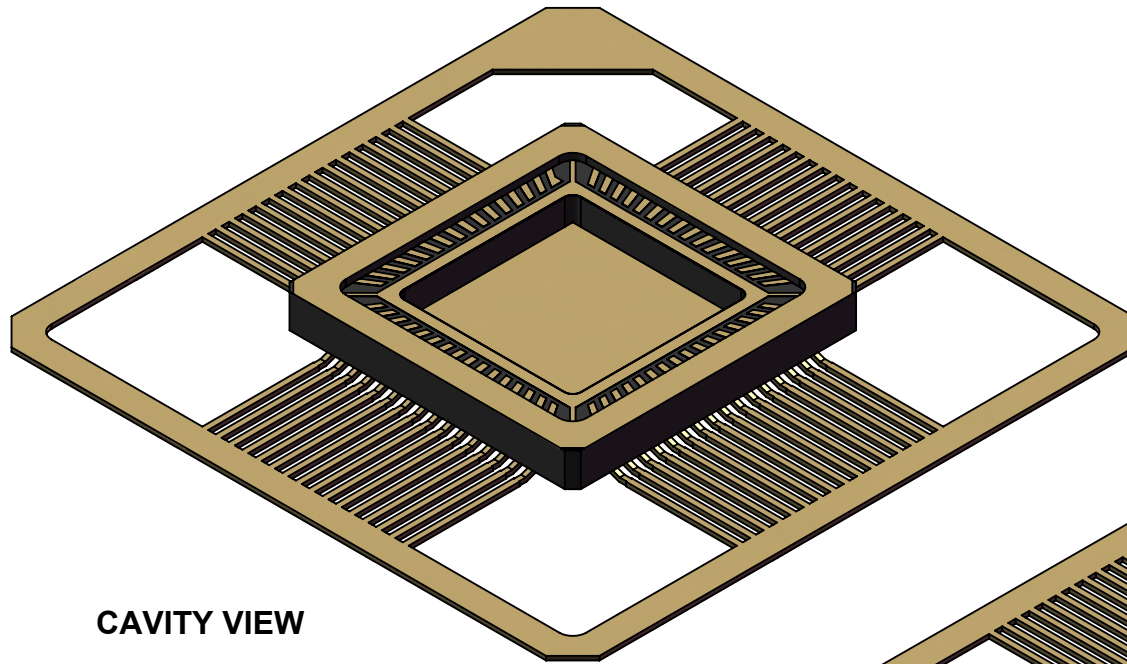

CAVITY VIEW

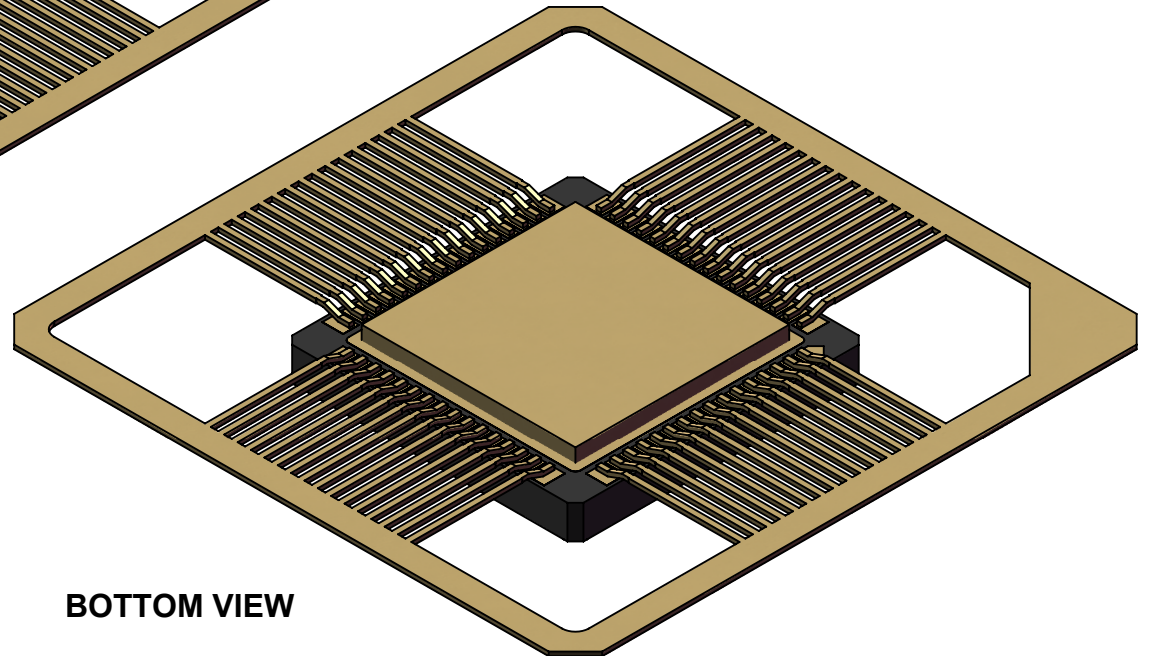

BOTTOM VIEW

TopLine®

TITLE CQFP64F19.7B-HS-N228
64L P=0.5mm

SCALE 5:1	SIZE A	DRAWING NO. 166400	REV A
--------------	-----------	-----------------------	----------

DO NOT SCALE DRAWING

SHEET 5 OF 6

OPTIONAL COMBO LID

BOTTOM

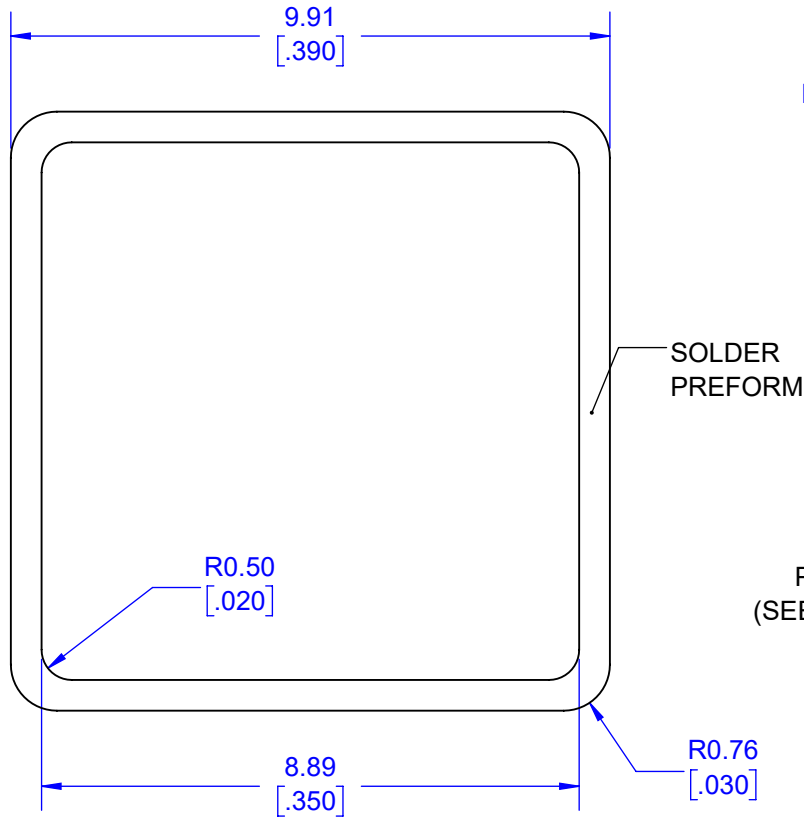

SIDE

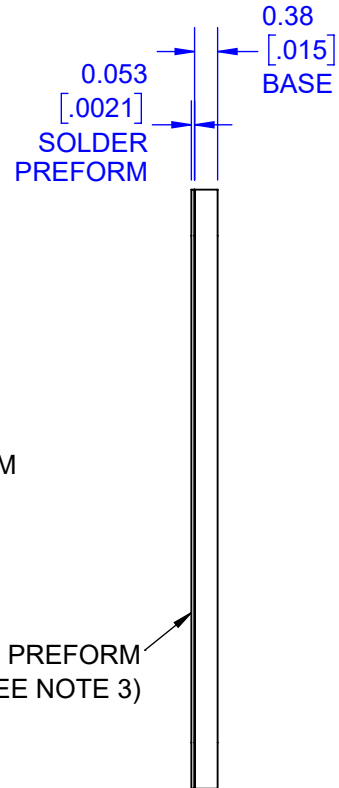

TOP

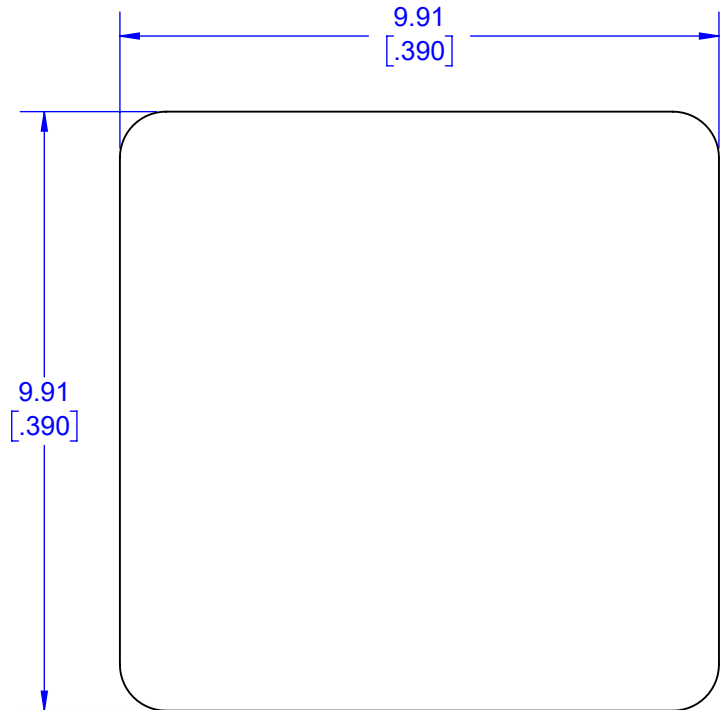

NOTES:

1. DIMENSIONS: MM [inch].
2. BASE MATERIAL: KOVAR or ALLOY 42.
3. PLATING: Ni 50~350 MICRO-INCH PER SIDE.
Au 25 MICRO-INCH MIN PER SIDE.
4. SOLDER PREFORM: Au 80% ±1.0 Sn 20%.
5. FLATNESS 1.0 MIL (25µm) MAXIMUM PER 0.5-inch (12.7mm).

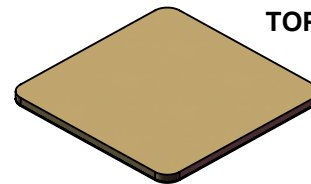

TOP

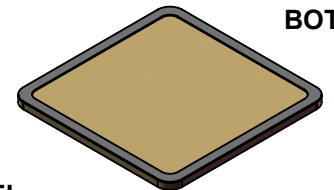

BOTTOM

MODEL

REF:
HR-C-968 / HRC-3549
W-711H

TopLine®			
TITLE		CL-390SQ-B COMBO LID	
SCALE	SIZE	DRAWING NO.	REV
8:1	A	163901	A
DO NOT SCALE DRAWING			SHEET 6 OF 6