

SIDE

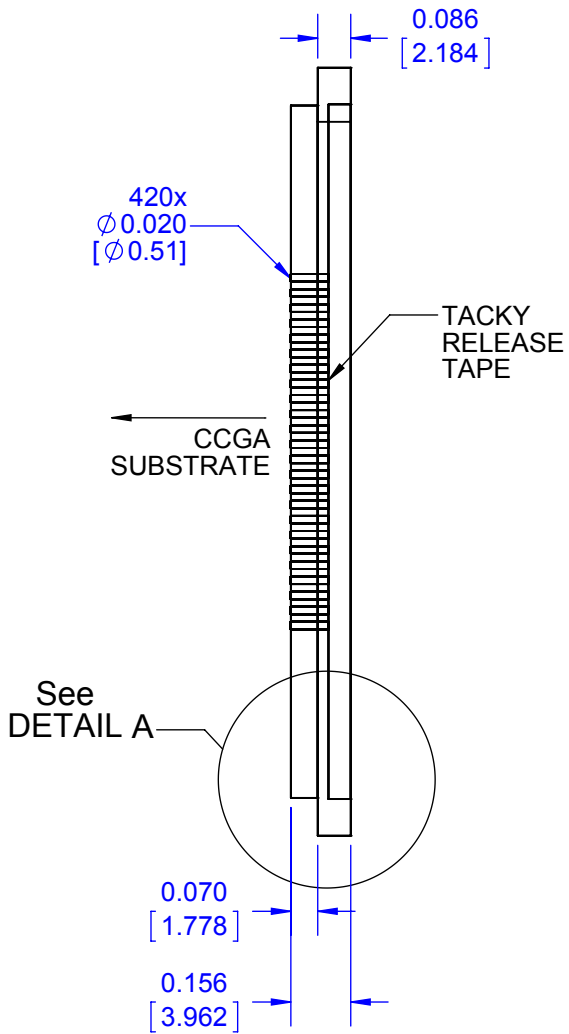

TOP VIEW

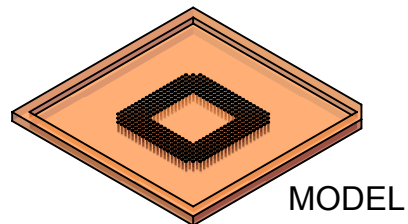
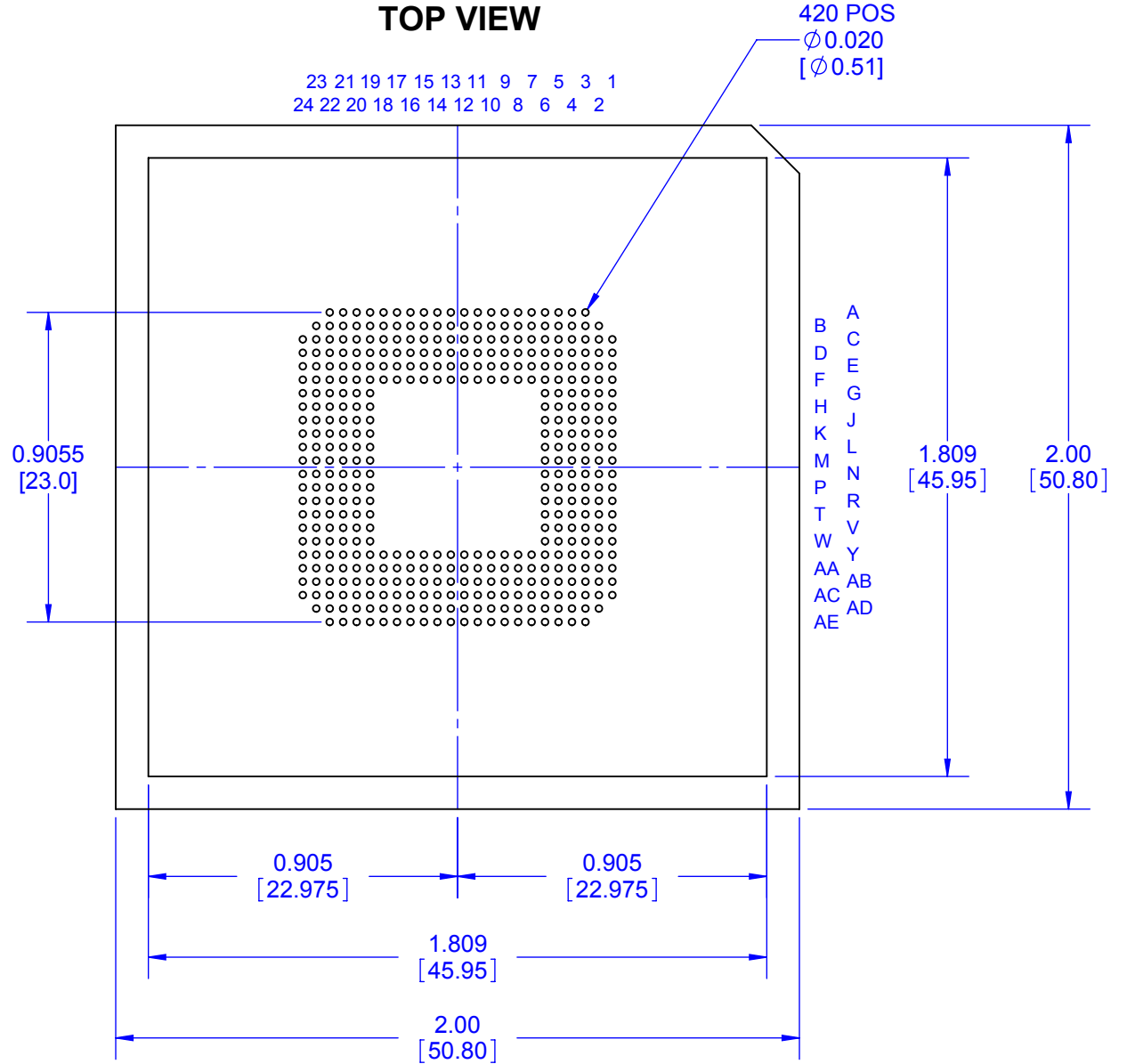

NOTES:
1. DIMENSIONS INCHES [MM].
2. SHOWN WITH MAXIMUM ARRAY.

TopLine®			
TITLE PP420 PIN-PACK™ CCGA COLUMN CARRIER			
SCALE 2:1	SIZE A	DRAWING NO. 001241	REV A
DO NOT SCALE DRAWING			SHEET 1 OF 8

DETAIL A

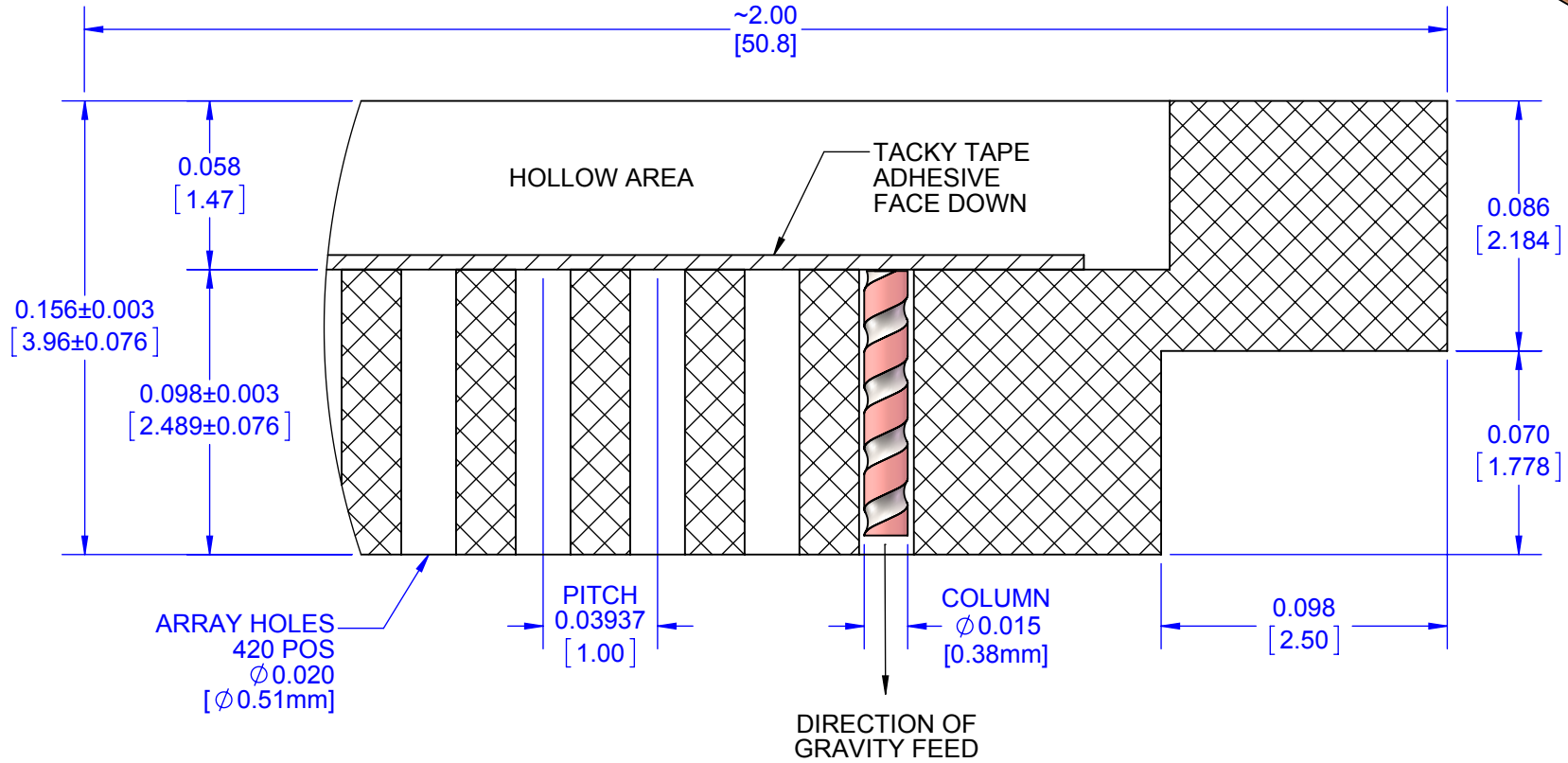
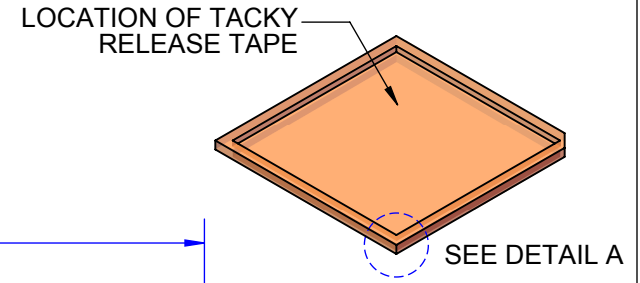

EXAMPLES OF COLUMNS

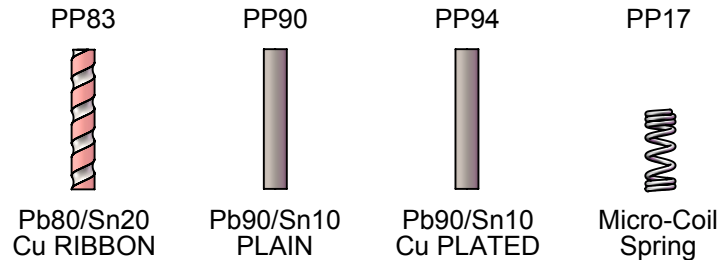

NOTES:
1. DIMENSIONS INCHES [MM].

TopLine®			
TITLE PP420 PIN-PACK™ CCGA COLUMN CARRIER			
SCALE 16:1	SIZE A	DRAWING NO. 001241	REV A
DO NOT SCALE DRAWING			SHEET 2 OF 8

PART NUMBER TABLE

PIN-PACK™	Pins	Pitch	Matrix	COLUMN BEFORE TRIM				Empty DWG	Filled DWG
				Alloy	Construction	∅ Dia	Length		
PP83C420E15x91A PP90U420E15x91A PP94E420E15x91A	420	1.0mm	24x24	Pb80 Pb90 Pb90	Cu Ribbon Plain Cu Plated	0.38mm	2.31mm	001241	831241 901241 941241
PP17P420E16x40A				MCS	Micro-Coil	0.40mm	1.00mm		171241

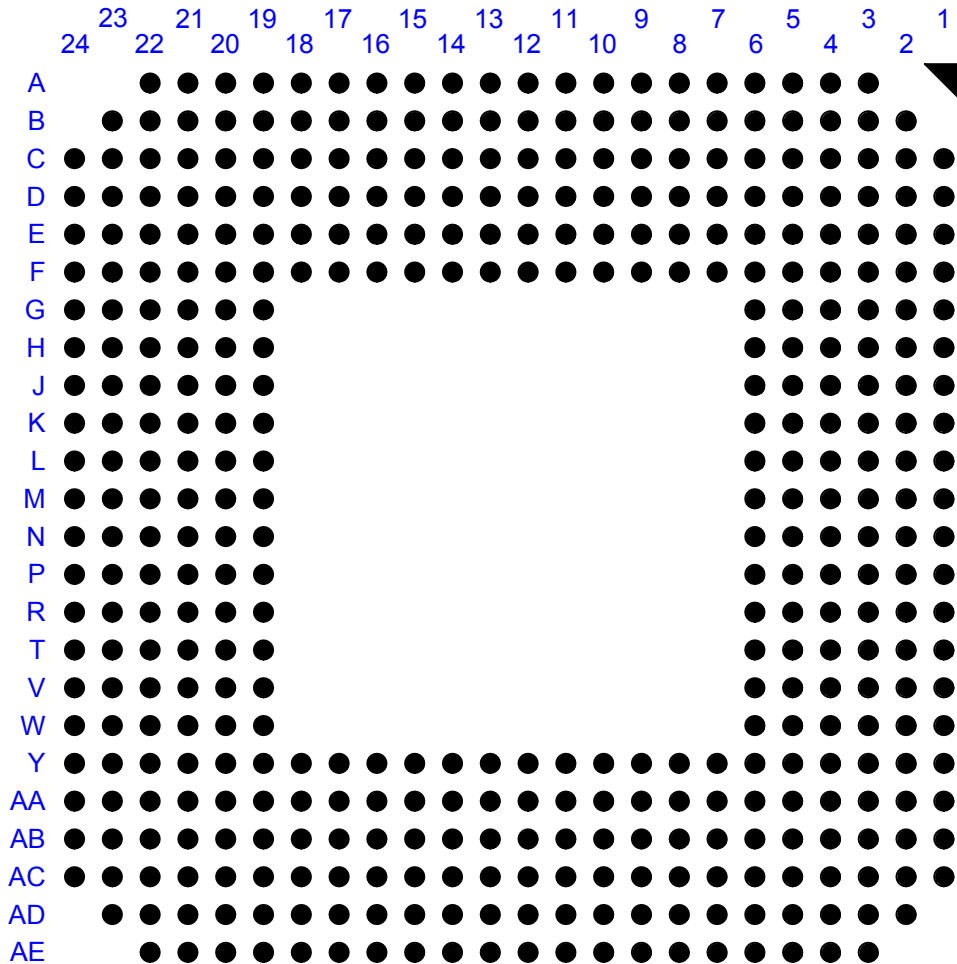

EXAMPLES OF COLUMNS

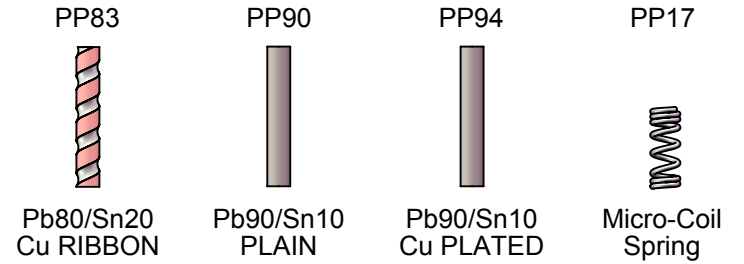

TopLine®			
TITLE PP420 PIN-PACK™ CCGA COLUMN CARRIER			
SCALE NONE	SIZE A	DRAWING NO. 001241	REV A
DO NOT SCALE DRAWING			SHEET 3 OF 8

PIN-PACK™ PART NUMBERING SYSTEM

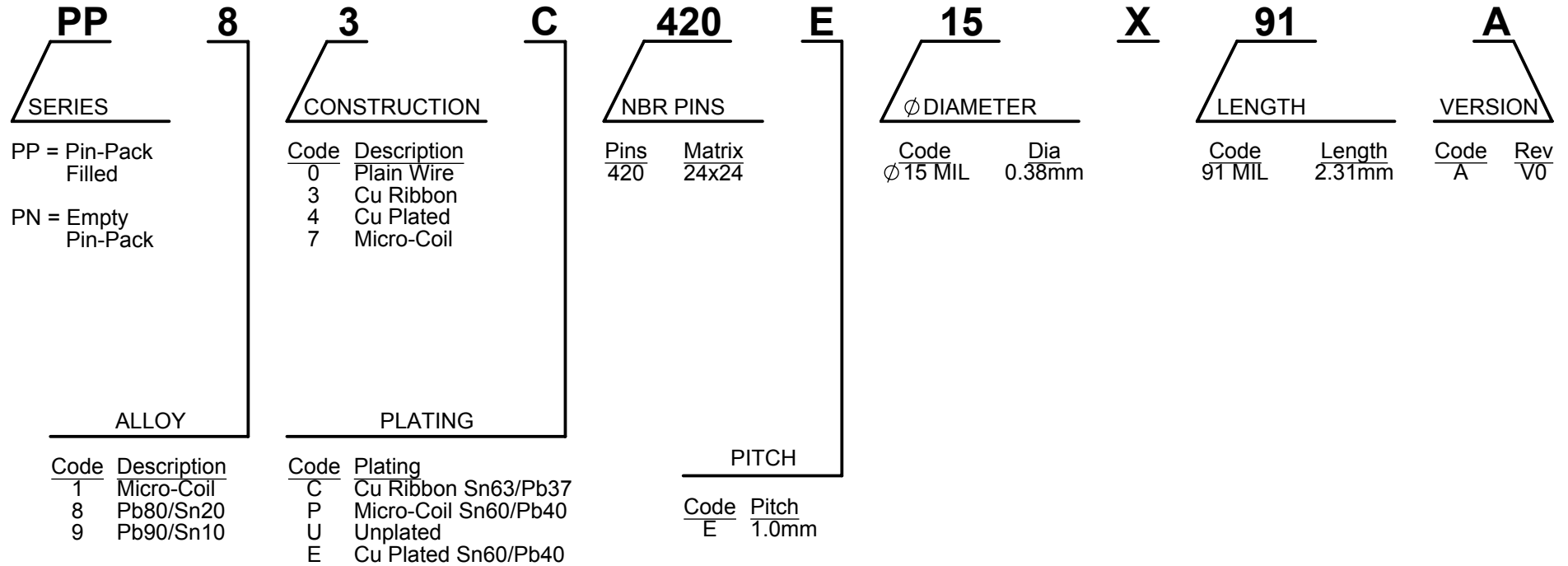

EXAMPLES OF COLUMNS

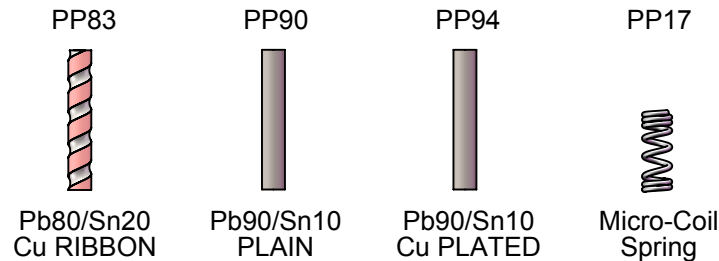

NOTE 1: COLUMN TO BE TRIMMED TO FINAL LENGTH AFTER ATTACHMENT.

TopLine®			
TITLE PP420 PIN-PACK™ CCGA COLUMN CARRIER			
SCALE 10:1	SIZE A	DRAWING NO. 001241	REV A
DO NOT SCALE DRAWING			SHEET 4 OF 8

PIN-PACK™ DRAWING NUMBERING SYSTEM

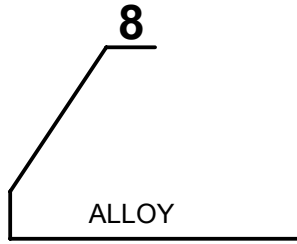

Code	Description
00	Empty
8	Pb80/Sn20
9	Pb90/Sn10

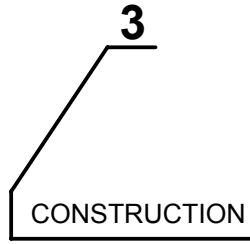

Code	Description
0	Plain Wire
3	Cu Ribbon
4	Cu Plated
7	Micro-Coil

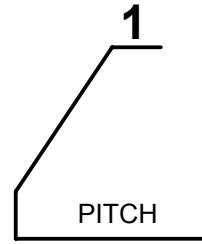

Code	Pitch
1	1.0mm

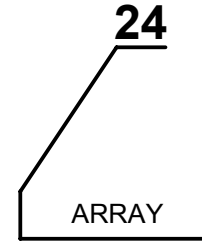



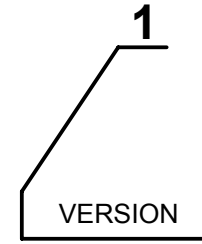

Code	Matrix
24	24x24



Code	Rev
1	420 PINS

EXAMPLES OF COLUMNS

PP83	PP90	PP94	PP17
			
Pb80/Sn20 Cu RIBBON	Pb90/Sn10 PLAIN	Pb90/Sn10 Cu PLATED	Micro-Coil Spring

TopLine®			
TITLE PP420 PIN-PACK™ CCGA COLUMN CARRIER			
SCALE 10:1	SIZE A	DRAWING NO. 001241	REV A
DO NOT SCALE DRAWING			SHEET 5 OF 8

PIN-PACK™ OUTLINE

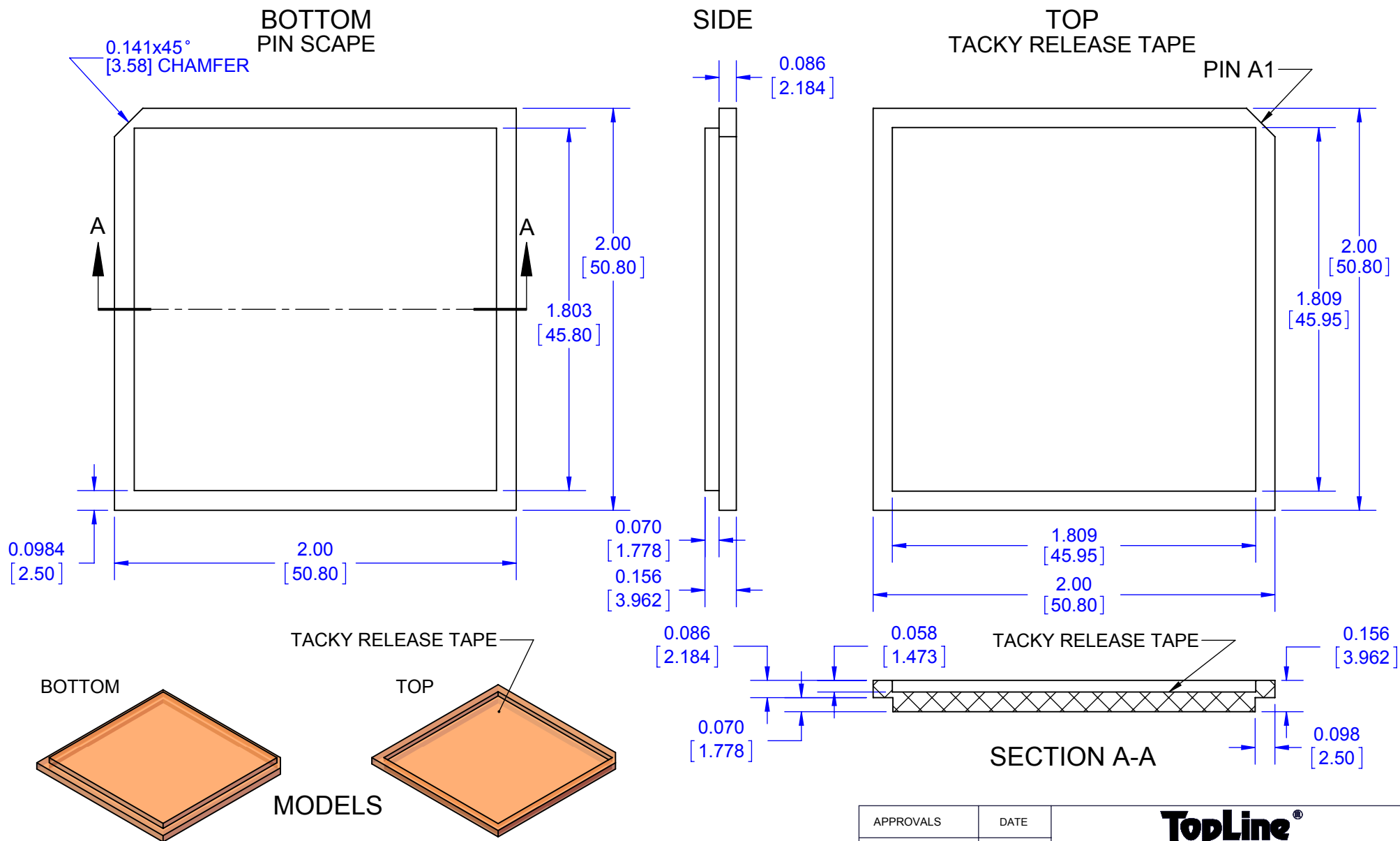

- NOTES:**
1. DIMENSIONS INCHES [MM].
 2. SHOWN WITHOUT HOLES FOR CLARITY.
 3. PIN-PACK™ IS TRADEMARK OF TOPLINE.
 4. PIN-PACK™ PATENT PENDING.

APPROVALS	DATE	TopLine®			
DRAWN T.Au	01/17/15				
ENG M. Hart	01/17/15	TITLE PP420 PIN-PACK™ CCGA COLUMN CARRIER			
MFG		SCALE	SIZE	DRAWING NO.	REV
QA		3:2	A	001241	A
CUST		DO NOT SCALE DRAWING			SHEET 6 OF 8
REVISED					

TACKY RELEASE TAPE TOP VIEW

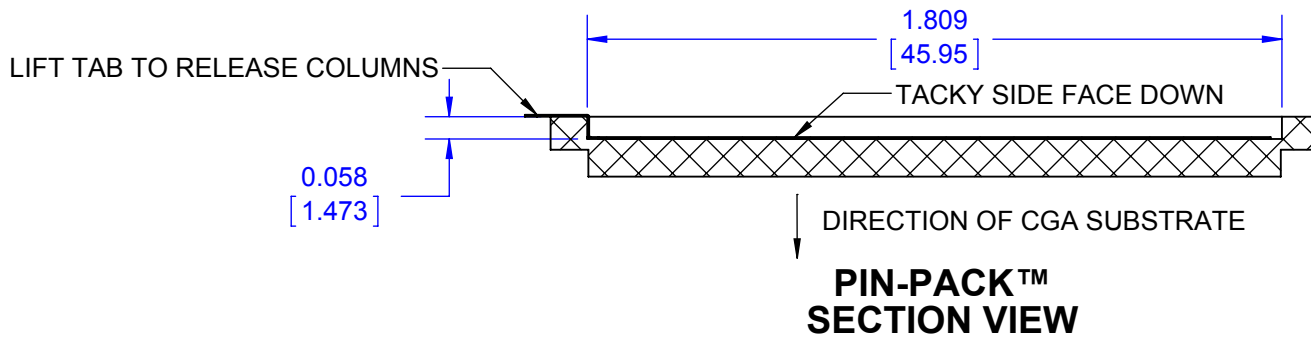
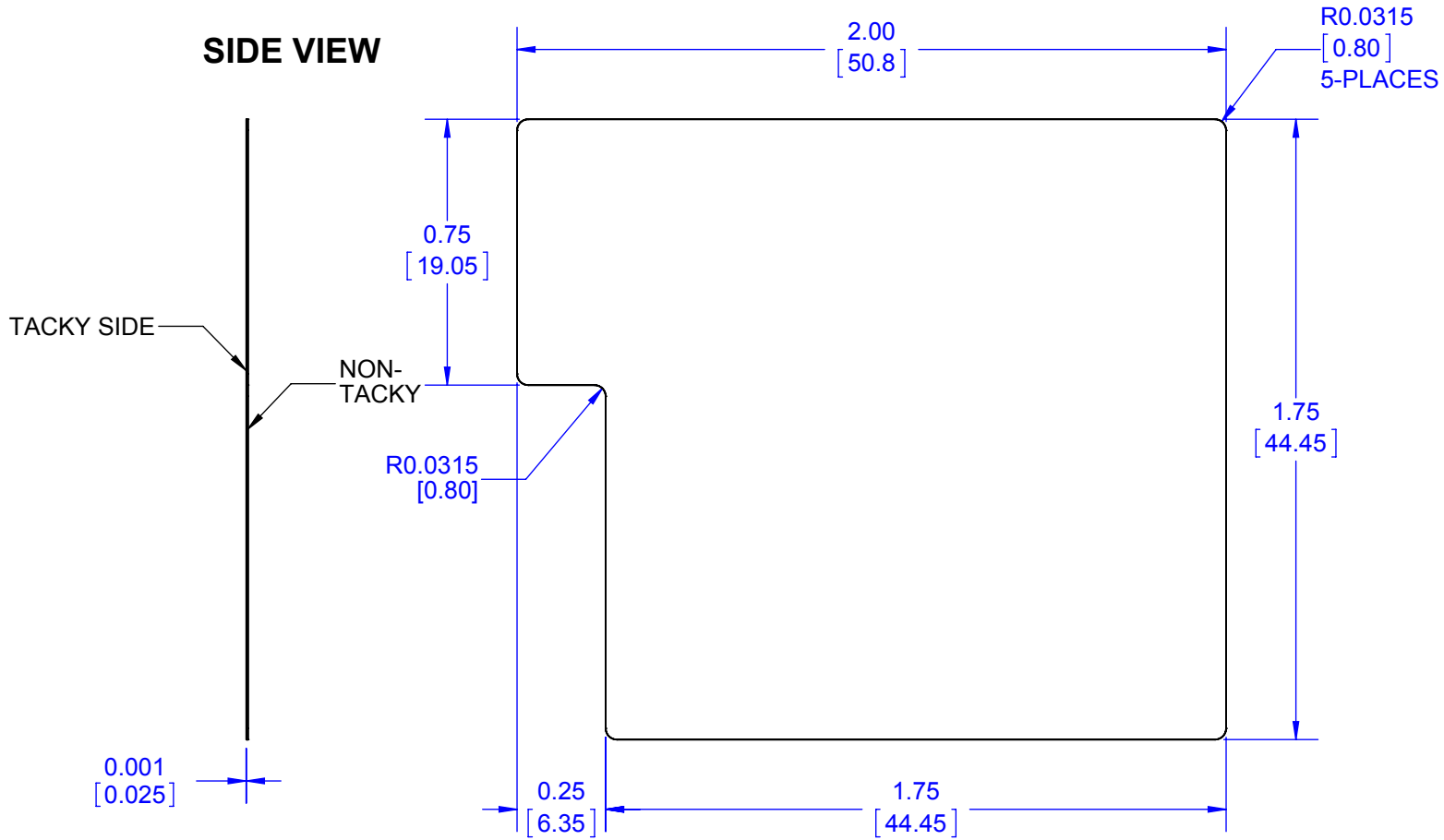

TopLine®			
TITLE PP420 PIN-PACK™ CCGA COLUMN CARRIER			
SCALE 2:1	SIZE A	DRAWING NO. 001241	REV B
DO NOT SCALE DRAWING			SHEET 7 OF 8

TACKY RELEASE TAPE MODEL

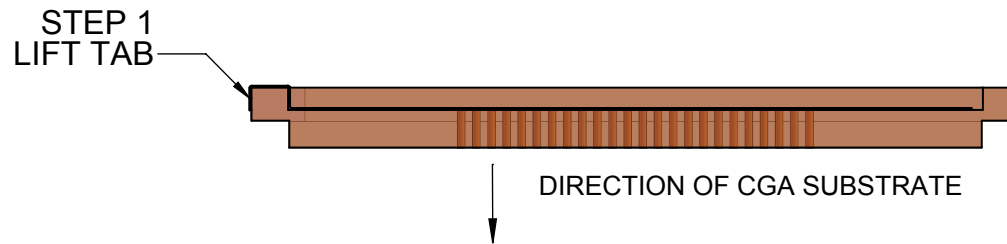
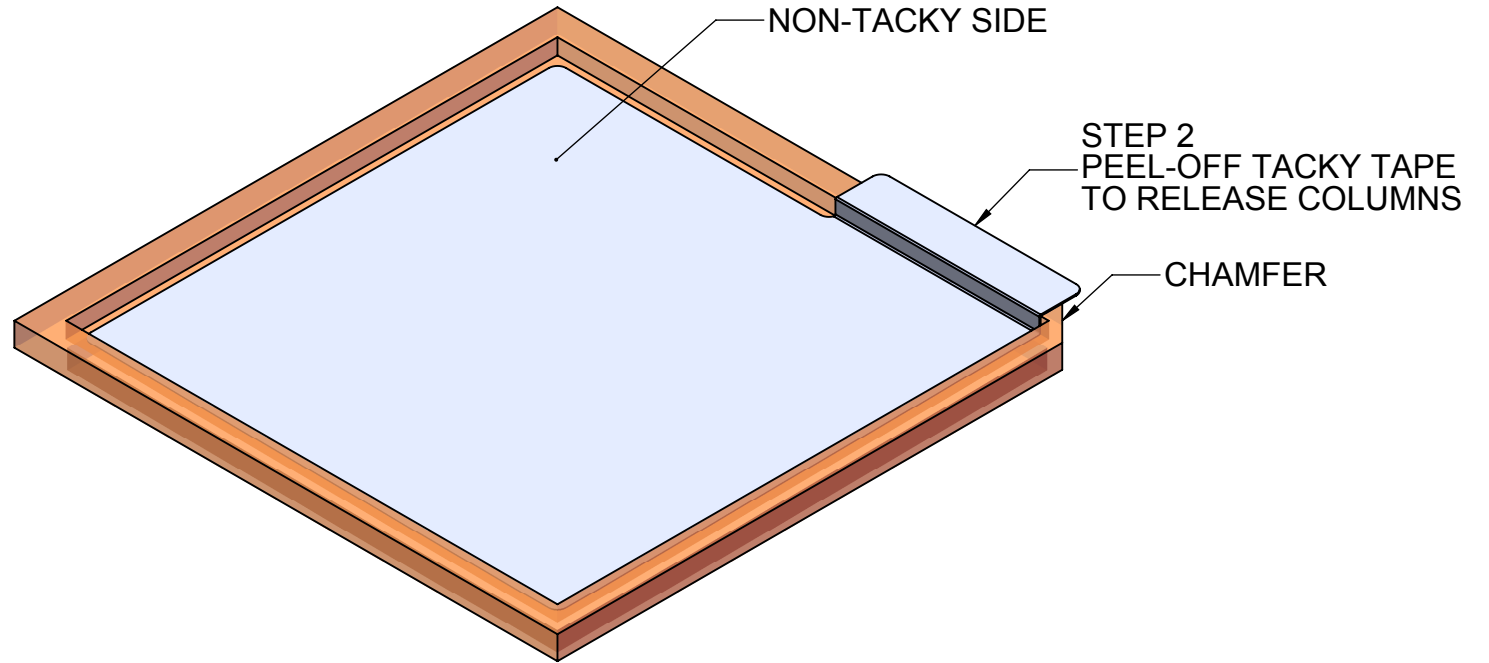

TopLine[®]			
TITLE PP420 PIN-PACK™ CCGA COLUMN CARRIER			
SCALE 1.5:1	SIZE A	DRAWING NO. 001241	REV B
DO NOT SCALE DRAWING			SHEET 8 OF 8