

### EXTERIOR VIEW

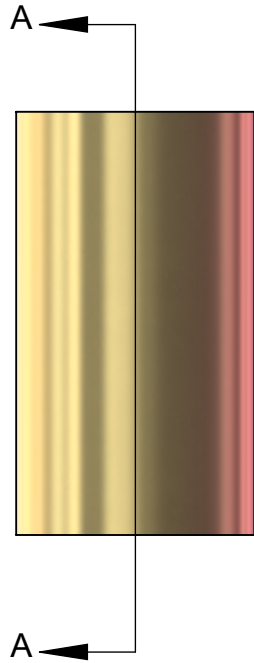

### SECTION VIEW

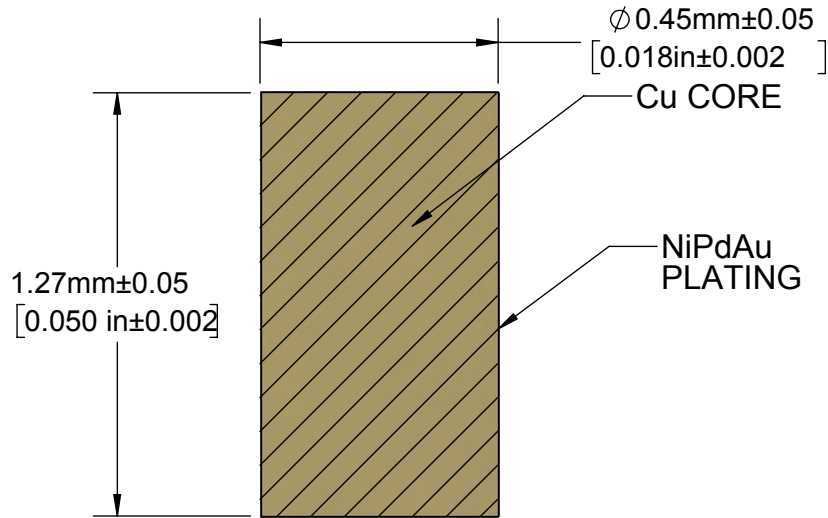

### CCGA - LAND PAD

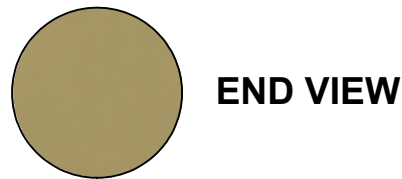
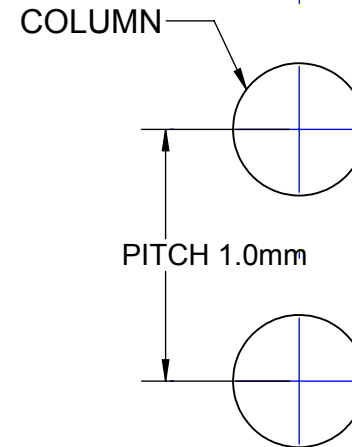
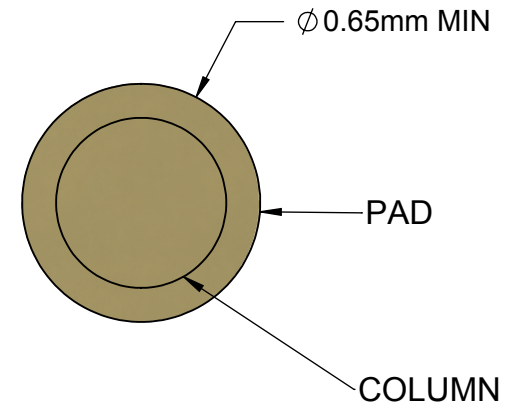

**END VIEW**

- Notes: (Unless Otherwise Specified).  
 1) DIMENSIONS IN mm [INCHES].  
 2) MATERIAL: Cu ALLOY CDA101 ~ Cu 99.99 (OFHC-101) 4N  
 3) PLATING: Electroless Ni 2.0~6.0µm, Pd 0.05 ~ 0.30µm, Au 0.05 ~ 0.30µm

APPROVALS	DATE	<b>TopLine®</b>			
DRAWN T. Au	9/19/2018				
ENG M. Hart	9/19/2018	TITLE CU101F18x50 COPPER PILLAR			
MFG		SCALE	SIZE	DRAWING NO.	REV
QA		50:1	A	611850	A
CUST		DO NOT SCALE DRAWING			SHEET 1 OF 1
REVISED					