

TOP VIEW

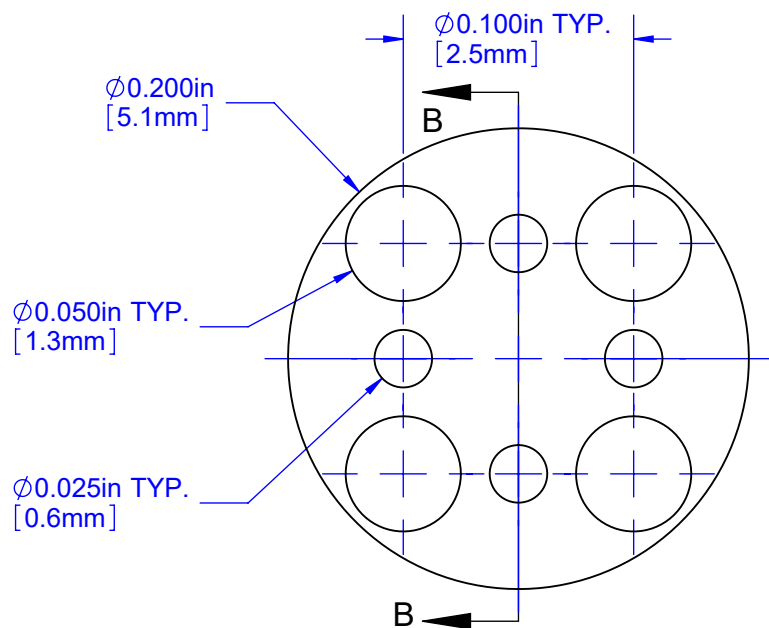

SIDE VIEW

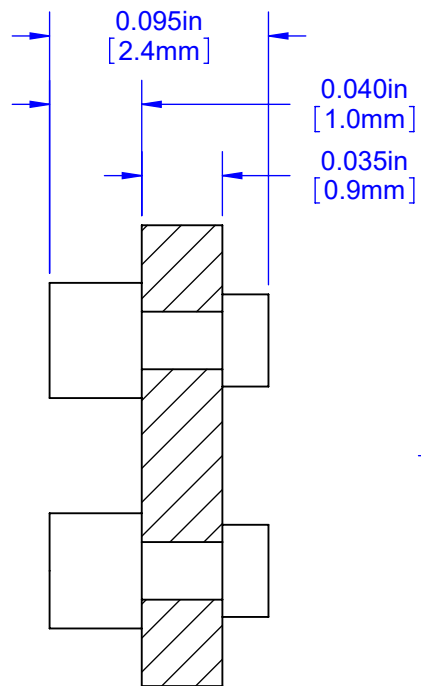

SECTION B-B

BOTTOM VIEW

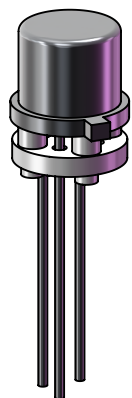
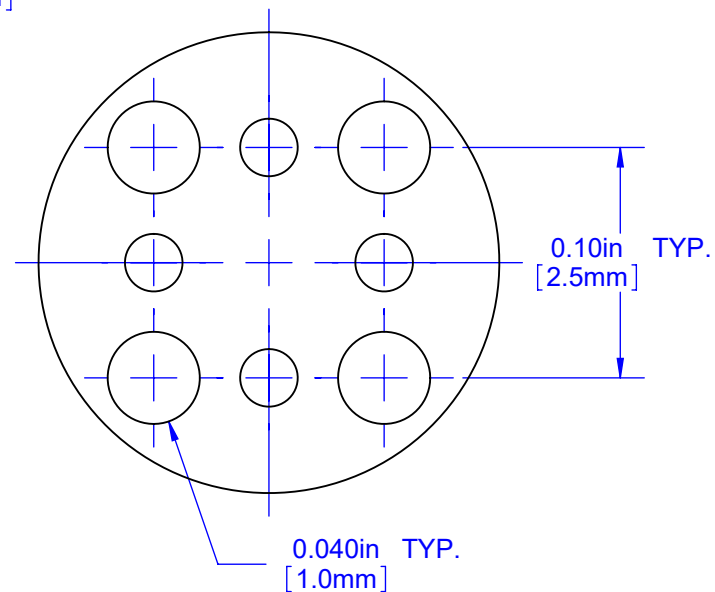

TO-18 COMPONENT MOUNTED IN THE SPACER

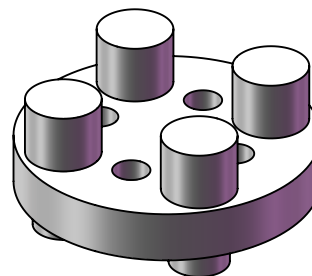

STANDOFF WITHOUT TO-18

NOTES:

1. TOLERANCE .XX= $\pm 0.01"$ (0.25mm) .XXX = $\pm 0.005"$ (0.13mm).
2. MATERIAL: NATURAL NYLON 6/6 UL RATED 94V-2.
3. MIL EQUIVALENT: M38527 / 01-030N.
4. ALTERNATE: A55485/01-030N.

APPROVALS	DATE	TopLine®			
DRAWN T. Au	05/27/16				
ENG M. Hart	05/27/16	TITLE TO-18 STAND OFF			
MFG		SCALE 12:1	SIZE A	DRAWING NO. 115100	REV A
QA		DO NOT SCALE DRAWING			SHEET 1 OF 1
CUST					
REVISED					