

### TOP VIEW

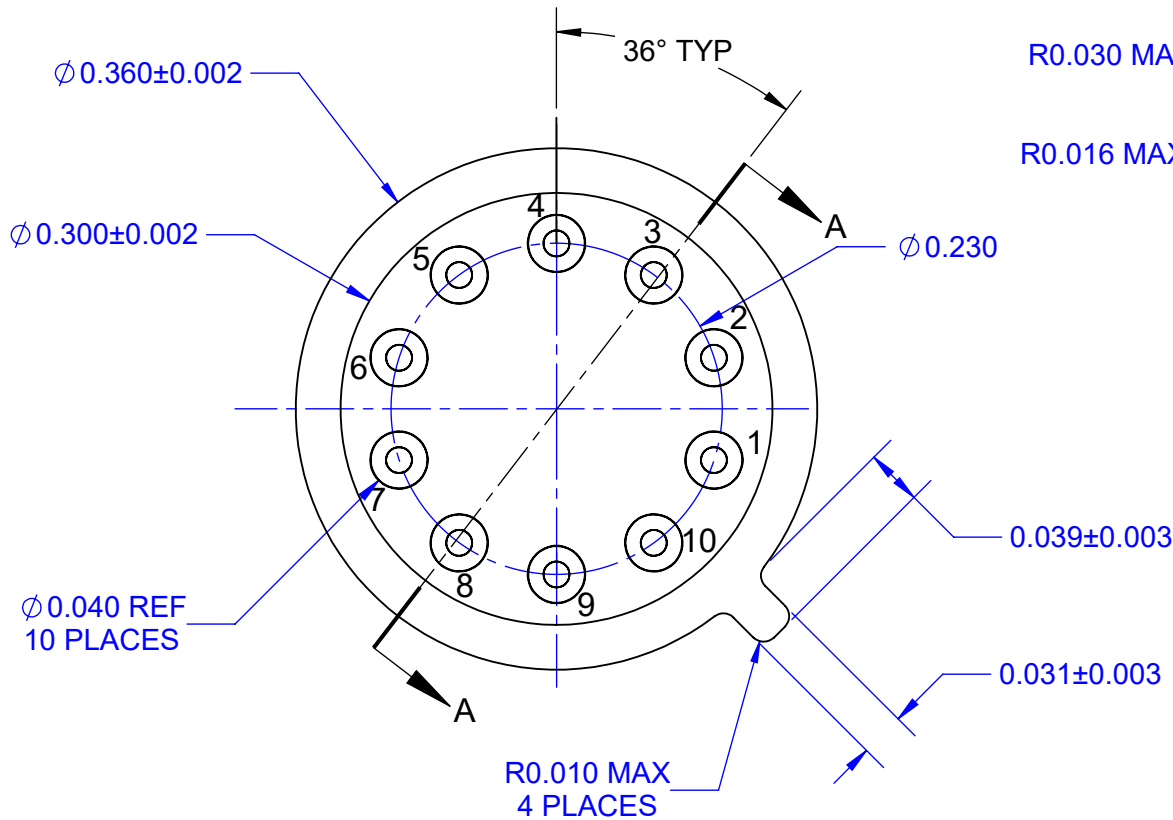

### SECTION VIEW A-A

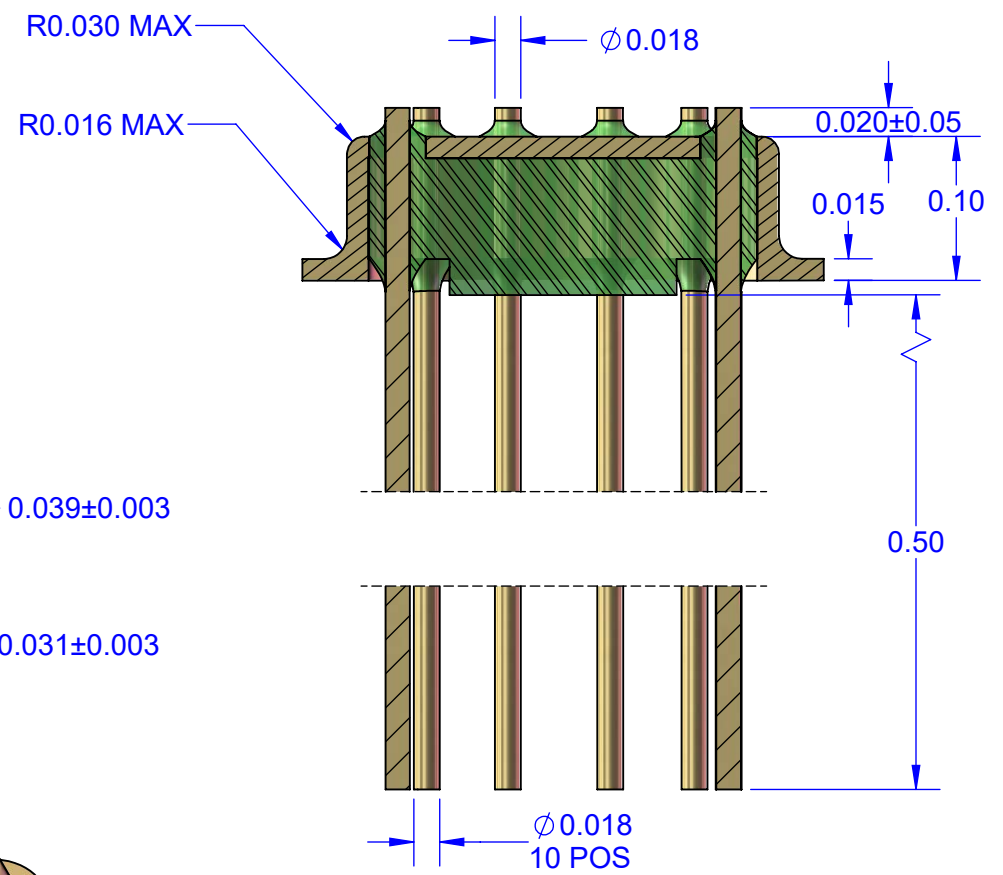

STRAIGHT POST TOP SURFACE FREE OF GLASS

SECTION A-A  
SCALE 7.5 : 1

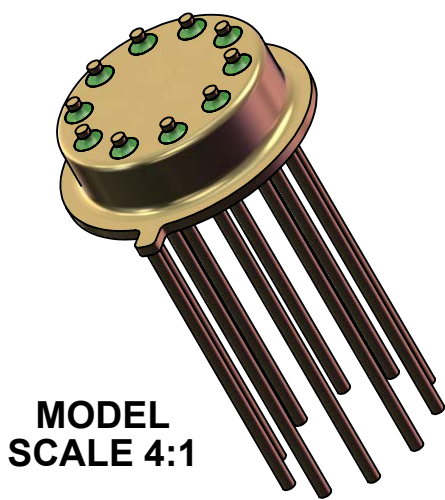

- NOTES:
1. DIMENSIONS INCH (Unless Otherwise Specified).
  2. BODY KOVAR ASTM F45 ALLOY 42.
  3. LEADS KOVAR ASTM F15.
  4. GLASS 7052 OR EQUIVALENT.
  5. PLATING: Ni 100~300 Micro-inch  
Au 50 Micro-inch MIN

**MODEL  
SCALE 4:1**

APPROVALS	DATE	<b>TopLine®</b>			
DRAWN T. Au	5/10/2022				
ENG M. Hart	5/10/2022	TITLE TO-5 HEADER 10L STRAIGHT POST ISOLATED			
MFG		SCALE	SIZE	DRAWING NO.	REV
QA		7.5:1	A	143910	A
CUST		DO NOT SCALE DRAWING			SHEET 1 OF 1
REVISED					