

HEAT SPREADER

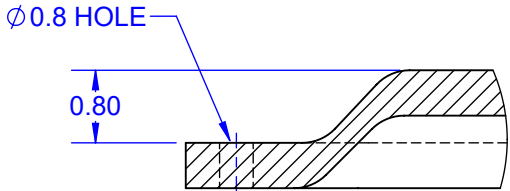

DETAIL A
SCALE 12 : 1

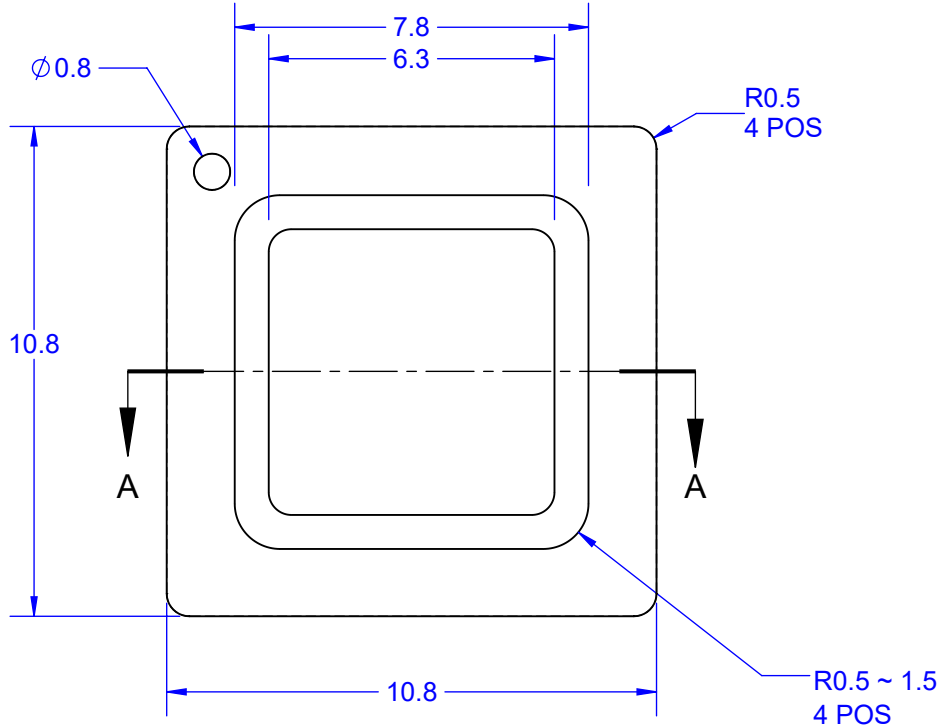
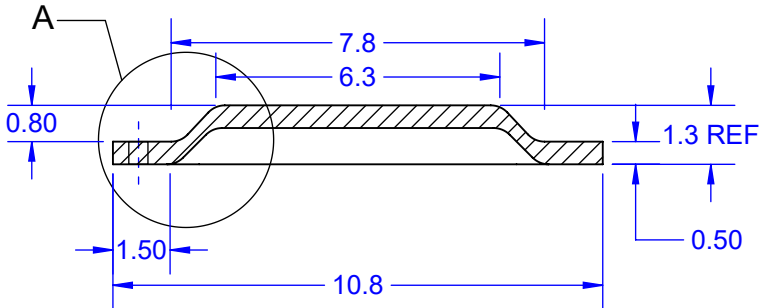

SECTION A-A
SCALE 6 : 1



TOP

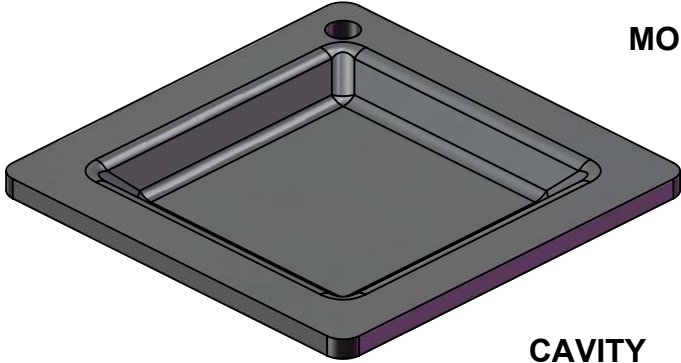

MODEL

CAVITY

NOTES:

- 1. DIMENSIONS: MM
- 2. MATERIAL: COPPER ALLOY C1020 OR C1100
HALF HARD, OXYGEN FREE
- 3. PLATING: NICKEL 5um MIN (SEMI FINISH)

APPROVALS	DATE	TopLine®			
DRAWN T. Au	5/8/2024				
ENG M. Hart	5/8/2024	TITLE H-CAP11A HEAT SPREADER			
MFG		SCALE	SIZE	DRAWING NO.	REV
QA		6:1	A	211710	A
CUST		DO NOT SCALE DRAWING			SHEET 1 OF 1
REVISED					