

ASSEMBLY EXPLODED VIEW

U.S. PATENT No.
9,108,262 and 9,629,259

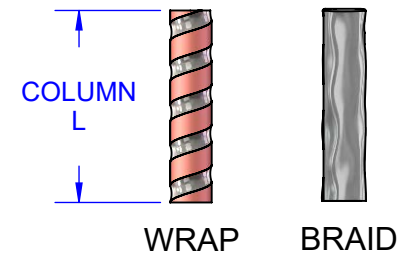

DIMENSION TABLE			
H	L MAX	W	DWG
4.02mm 0.158"	2.54mm 0.100"	1.82mm 0.072"	120254

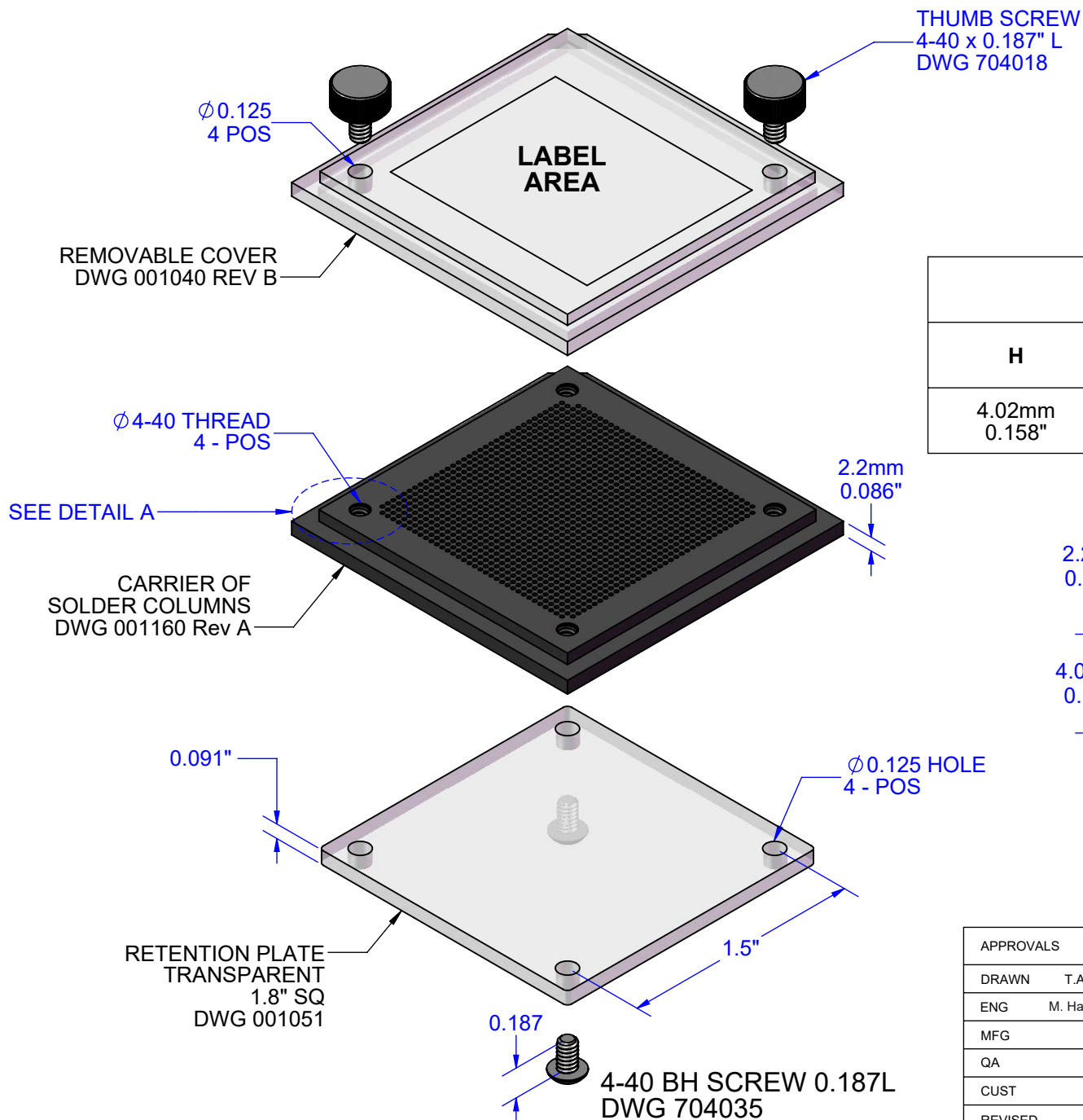
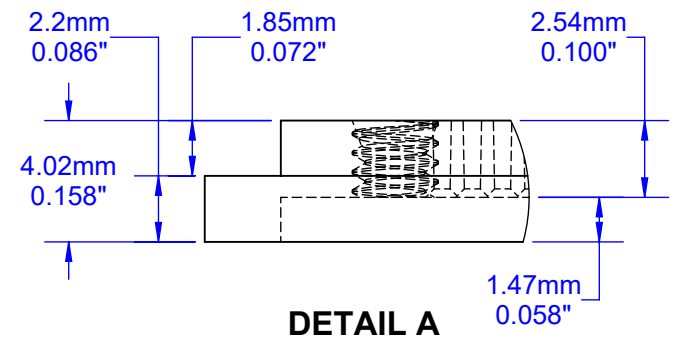

APPROVALS	DATE	TopLine®			
DRAWN T. Au	09/15/2024				
ENG M. Hart	09/15/2024	TITLE FP1291A FLIP-PACK® CCGA COLUMN CARRIER			
MFG		SCALE 1.25:1	SIZE A	DRAWING NO. 001361	REV A
QA		DO NOT SCALE DRAWING			SHEET 1 OF 11
CUST					
REVISED					

PART NUMBER TABLE

FLIP-PACK®	Pins	Pitch	Matrix	COLUMN					Empty DWG	Filled DWG
				Alloy	Construction	Plating	Ø Dia	Length		
FP83C1291E20x93A	1291	1.0mm	36x36	Pb80	Cu Ribbon		0.51mm	2.36mm	001361	831361
FP85B1291E20x93A				Pb80	Braided	SnPb	0.51mm	2.36mm		851361
FP95B1291E20x93A				Pb90	Braided		0.51mm	2.26mm		951361

35 33 31 29 27 25 23 21 19 17 15 13 11 9 7 5 3 1
36 34 32 30 28 26 24 22 20 18 16 14 12 10 8 6 4 2

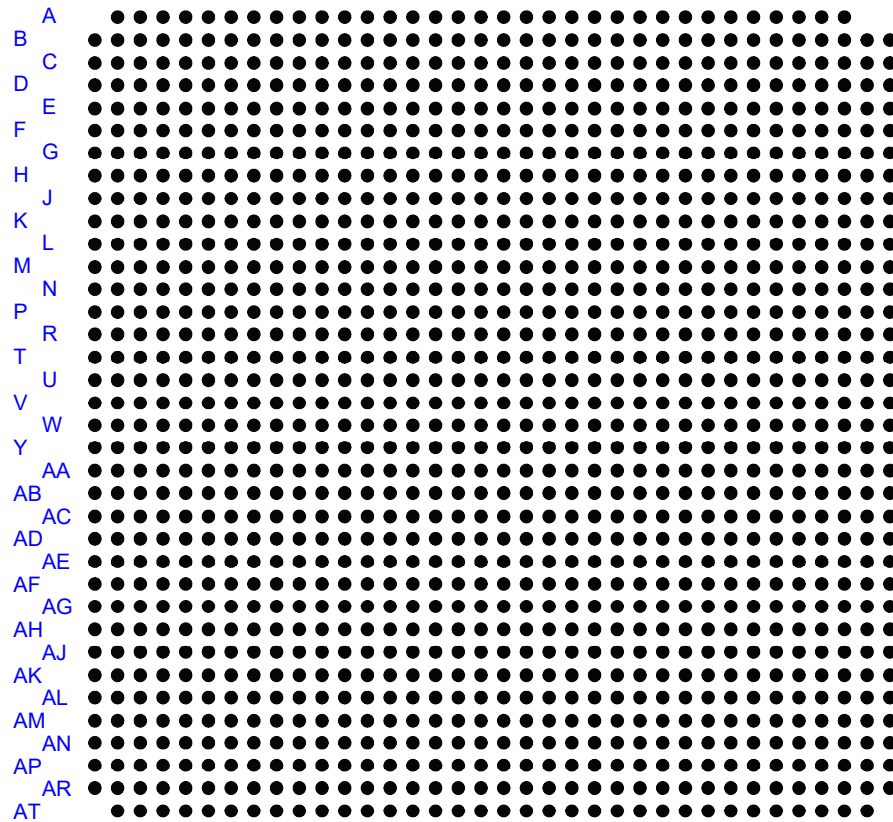

**BOTTOM
COUNTERSINK SIDE**

EXAMPLES OF COLUMNS

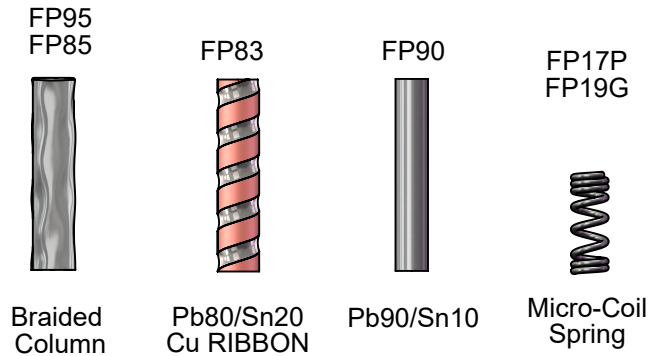

TopLine®			
TITLE FP1291A FLIP-PACK® CCGA COLUMN CARRIER			
SCALE NONE	SIZE A	DRAWING NO. 001361	REV A
DO NOT SCALE DRAWING			SHEET 2 OF 11

SIDE

TOP VIEW

TOP VIEW

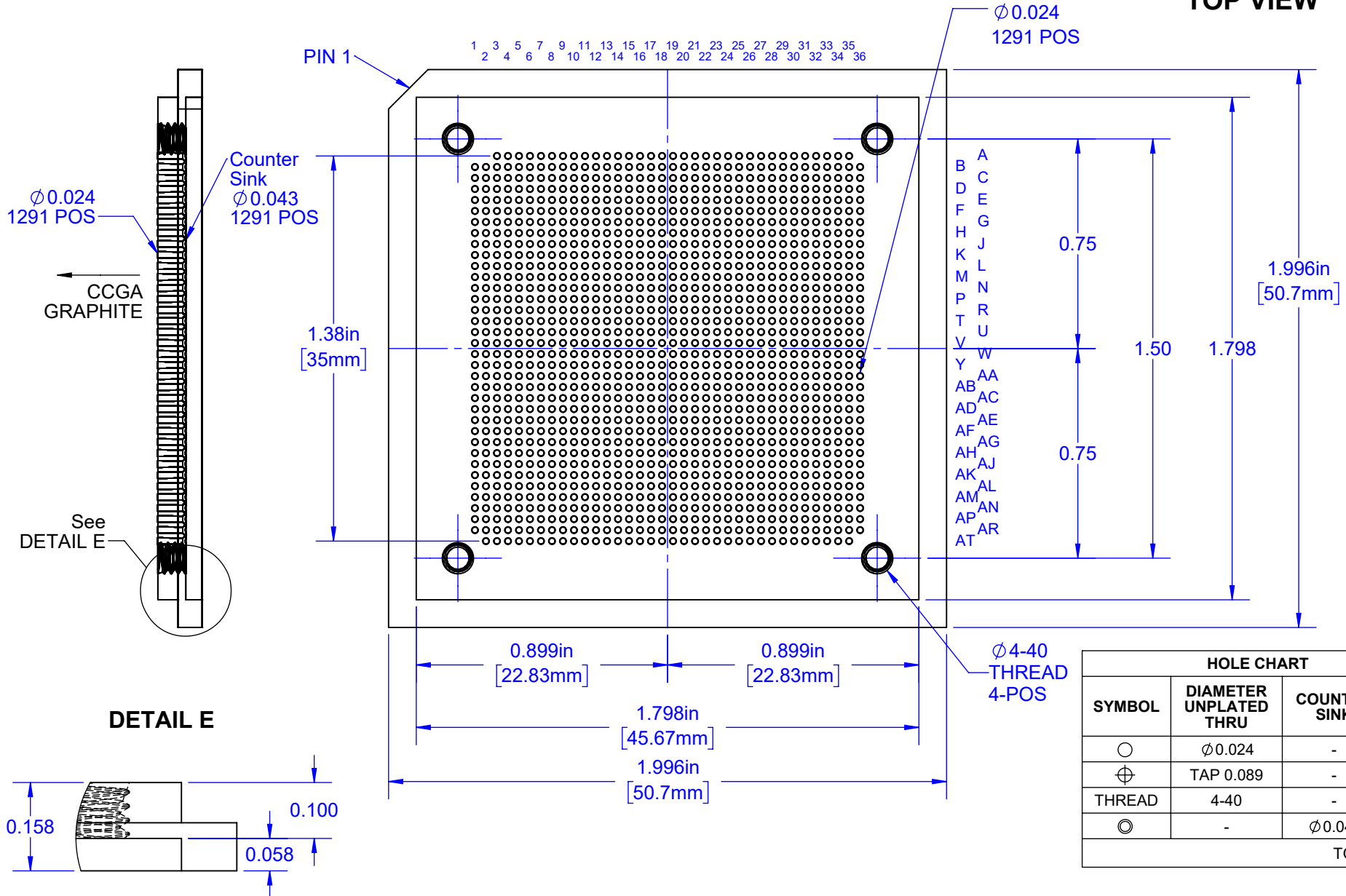

Notes: (Unless Otherwise Specified).
 1) MATERIAL: BLACK PLASTIC, CONDUCTIVE.
 2) DIMENSIONS : INCHES [MM].

HOLE CHART			
SYMBOL	DIAMETER UNPLATED THRU	COUNTER SINK	QTY
○	∅0.024	-	1291
⊕	TAP 0.089	-	4
THREAD	4-40	-	4
◎	-	∅0.043	1291
TOTAL			2586

TopLine®

TITLE FP1291A FLIP-PACK®
CCGA COLUMN CARRIER

SCALE 2:1	SIZE A	DRAWING NO. 001361	REV A
--------------	-----------	-----------------------	----------

DO NOT SCALE DRAWING SHEET 3 OF 11

DETAIL D WITH COVER PLATE

MODEL

THUMB SCREW

SEE DETAIL D

COVER

CARRIER

RETENTION
PLATE

SCREW

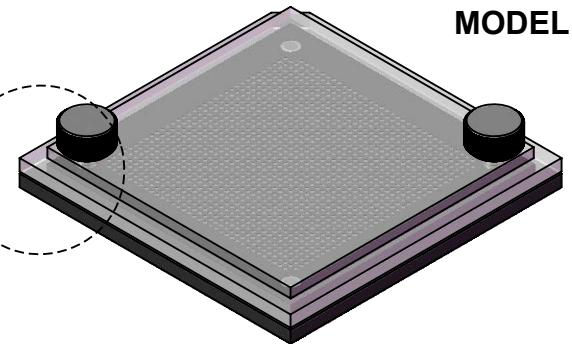
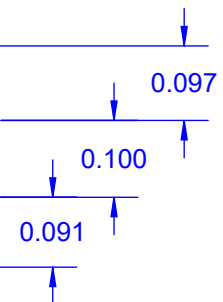

EXAMPLE OF COLUMNS

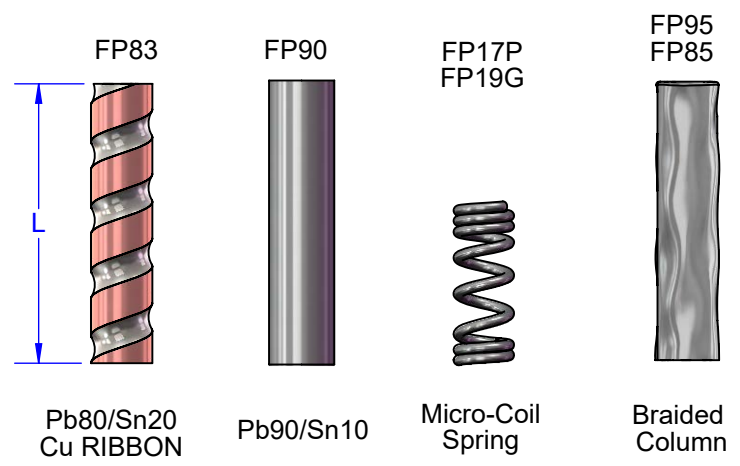

SCREW

RETENTION
PLATE

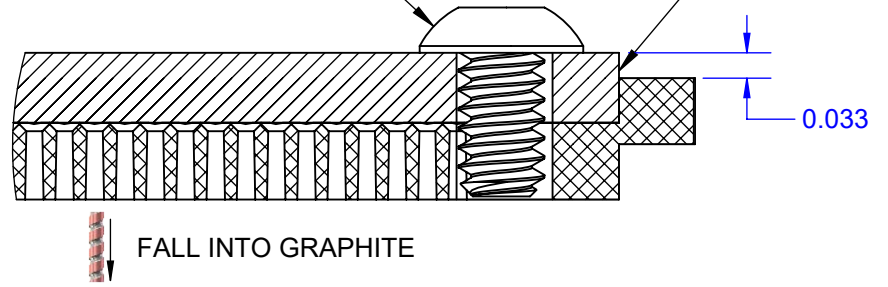

TopLine®			
TITLE FP1291A FLIP-PACK® CCGA COLUMN CARRIER			
SCALE 4:1	SIZE A	DRAWING NO. 001361	REV A
DO NOT SCALE DRAWING			SHEET 4 OF 11

FLIP PACK® MODEL

COVER 001040 REV B

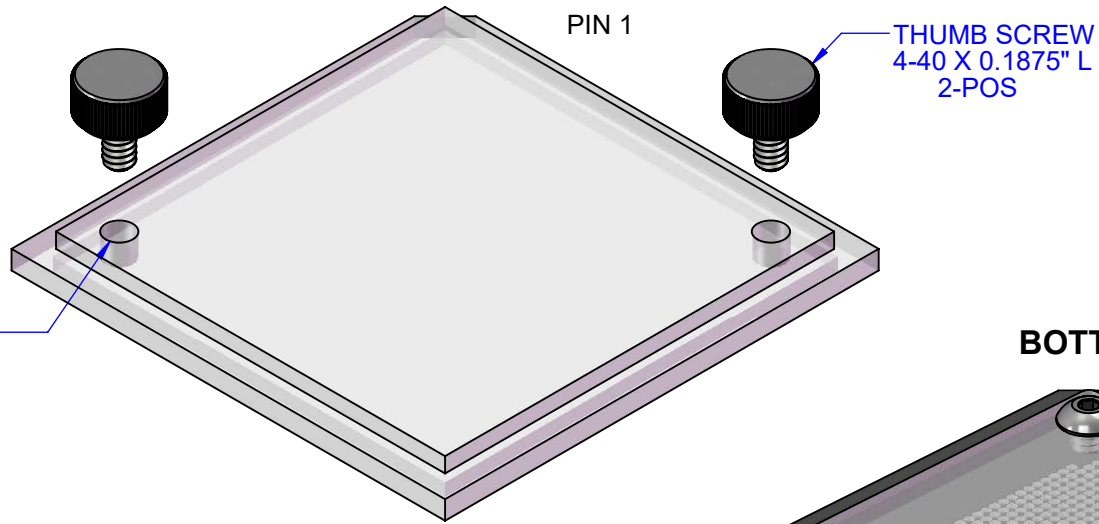

BOTTOM

RETENTION PLATE 001051
COUNTER SINK SIDE

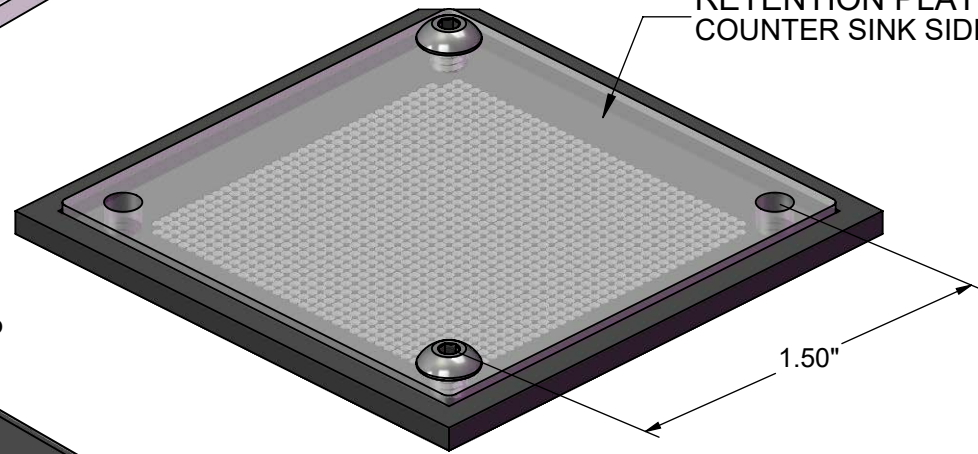

NO COUNTER SINK
THIS SIDE

TOP

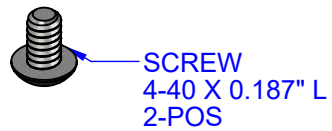
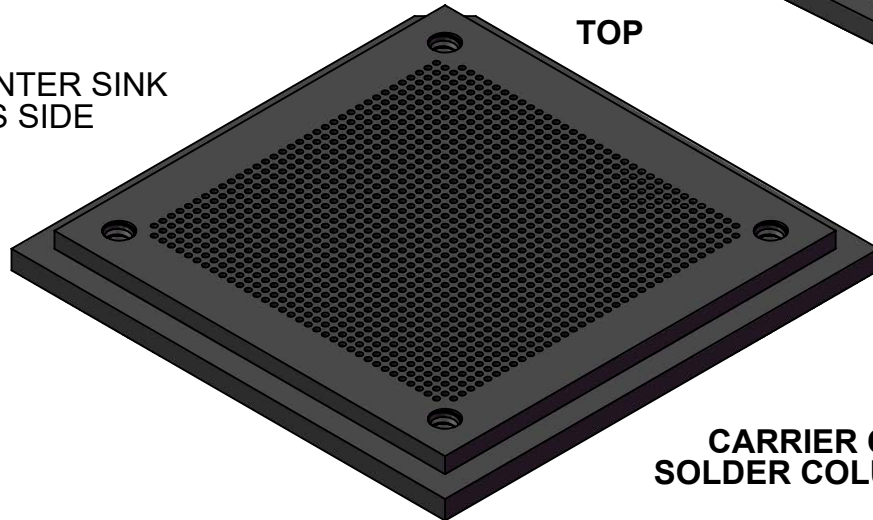

TopLine®

TITLE FP1291A FLIP-PACK®
CCGA COLUMN CARRIER

SCALE	SIZE	DRAWING NO.	REV
2:1	A	001361	A

DO NOT SCALE DRAWING

SHEET 5 OF 11

BOTTOM RETENTION PLATE

SIDE VIEW

TOP VIEW

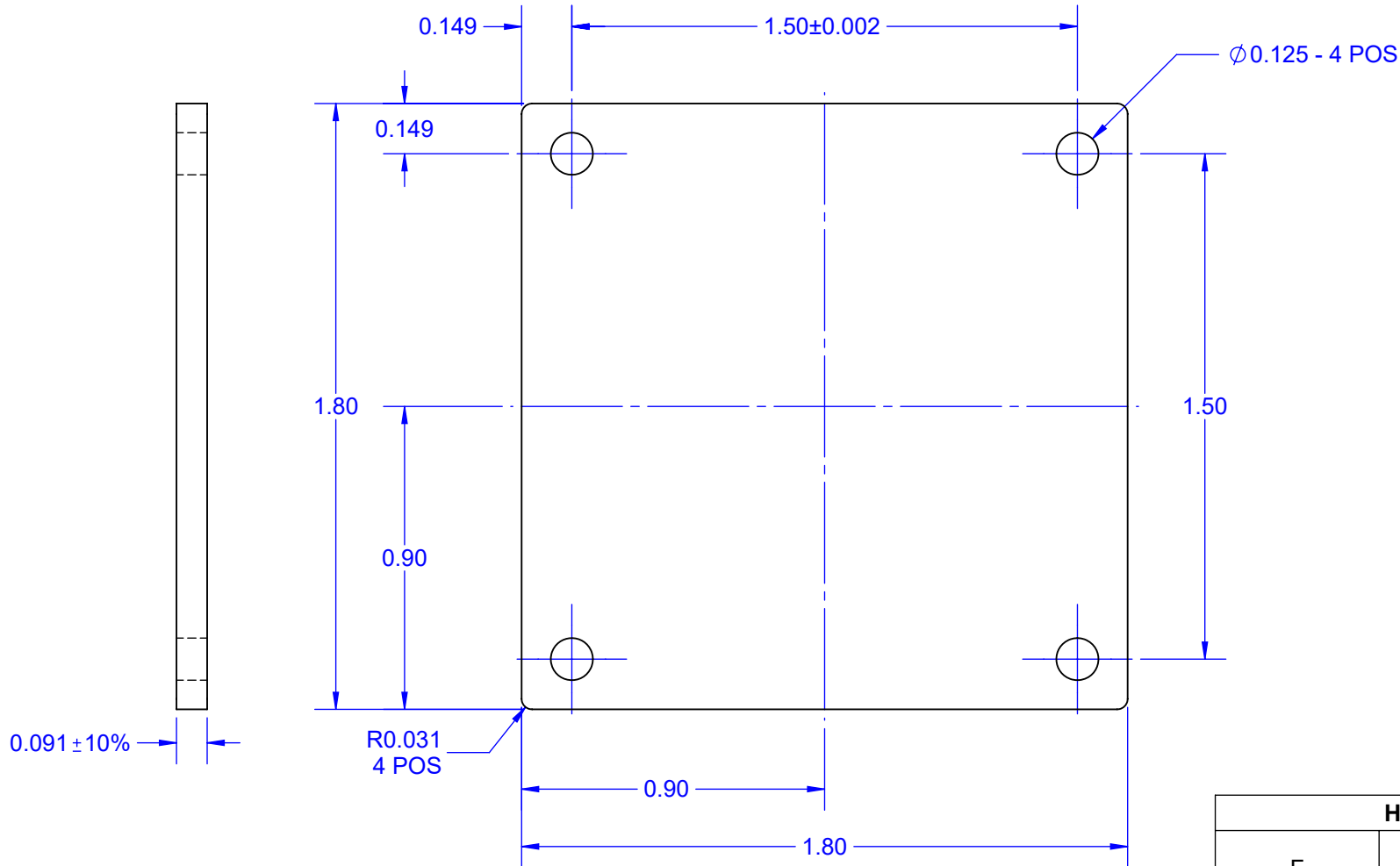

HOLE CHART		
F	DIAMETER UNPLATED	QTY HOLES
+	Ø0.125	4

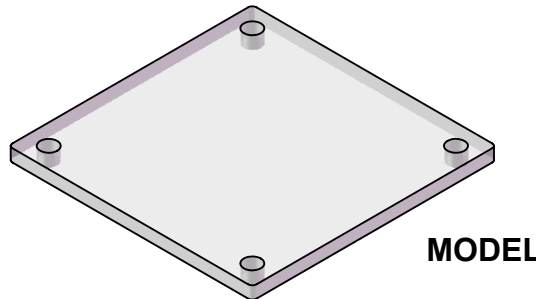

MODEL

NOTES: (Unless Otherwise Specified).

- 1) DIMENSIONS INCH.
- 2) MATERIAL: CLEAR PC-300 POLYCARBONATE.
- 3) STATIC DISIPATIVE $10^6 \sim 10^8 \Omega$. (ESD SAFE).
- 4) HOLE BREAK OUT ALLOWED.

			
TITLE FP1.8-BOTTOM-1.5B BOTTOM RETENTION PLATE			
SCALE 2:1	SIZE A	DRAWING NO. 001051	REV A
DO NOT SCALE DRAWING			SHEET 6 OF 11

COVER 001040 REV B

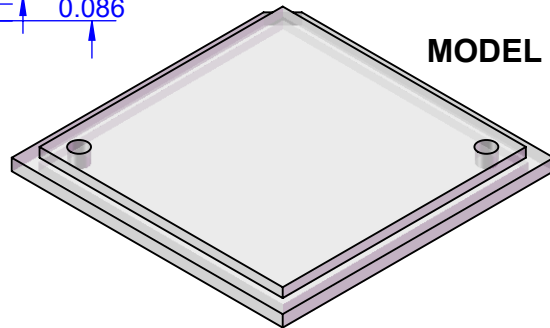
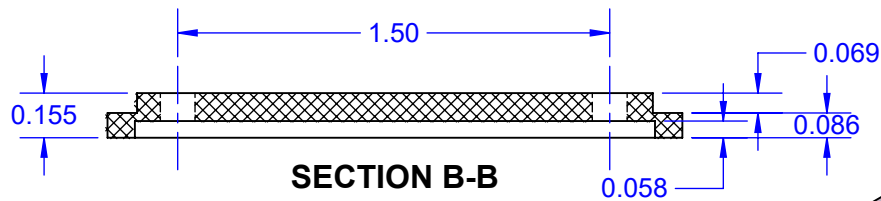
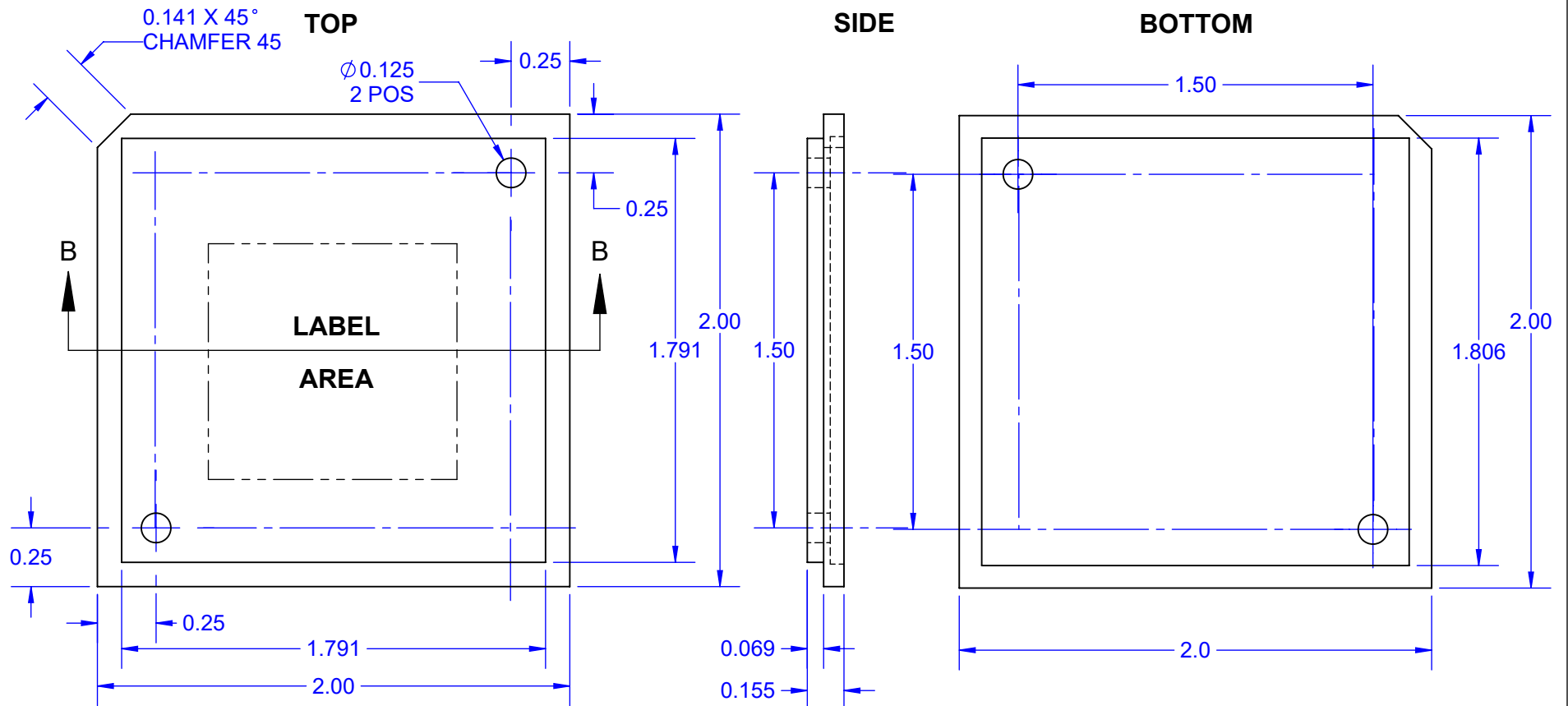

HOLE CHART		
SYMBOL	DIAMETER UNPLATED	QTY HOLES
+	Ø0.125	2

Notes: (Unless Otherwise Specified).

- 1) DIMENSIONS: INCH.
- 2) MATERIAL: TRANSPARENT PMMA PLASTIC.
- 3) ANTISTATIC: $10^{12} \Omega$ SURFACE RESISTANCE.

TopLine®			
TITLE FLIP-PACK® TOP COVER 2-INCH 1.50 SPACE			
SCALE 3:2	SIZE A	DRAWING NO. 001040	REV B
DO NOT SCALE DRAWING			SHEET 7 OF 11

FLIP-PACK® PART NUMBERING SYSTEM

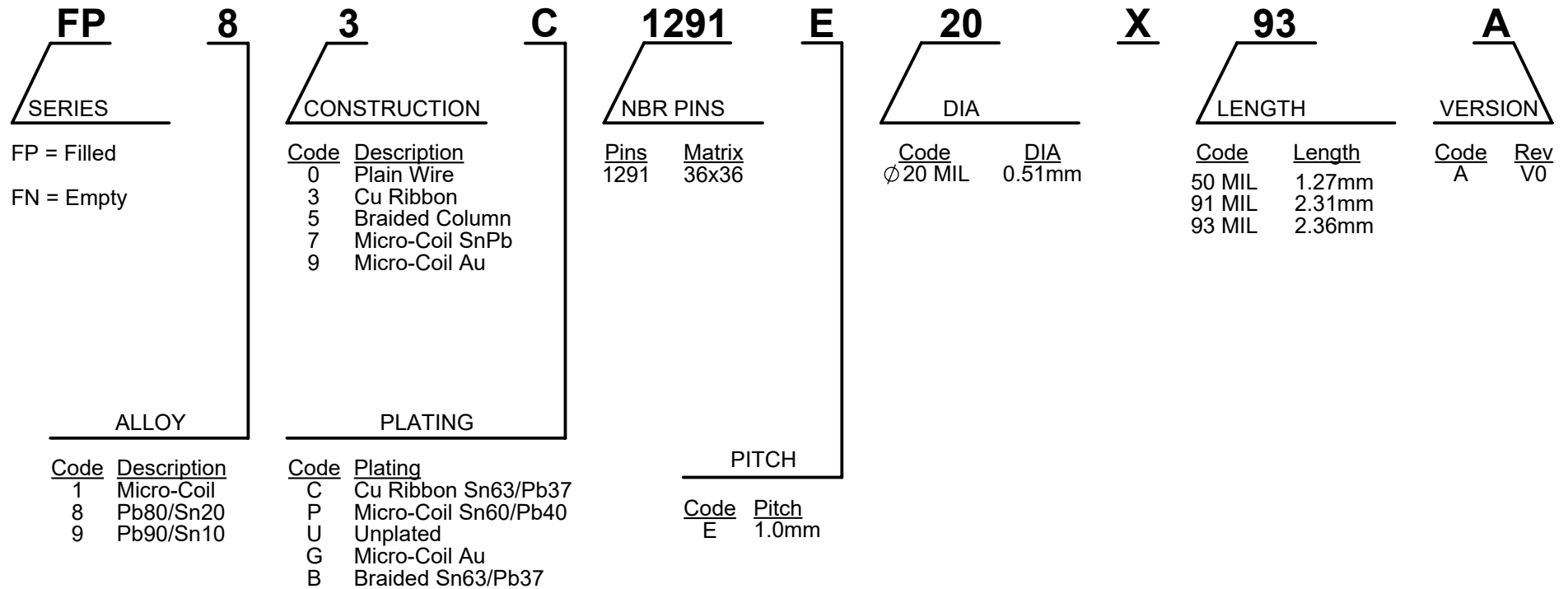

EXAMPLES OF COLUMNS

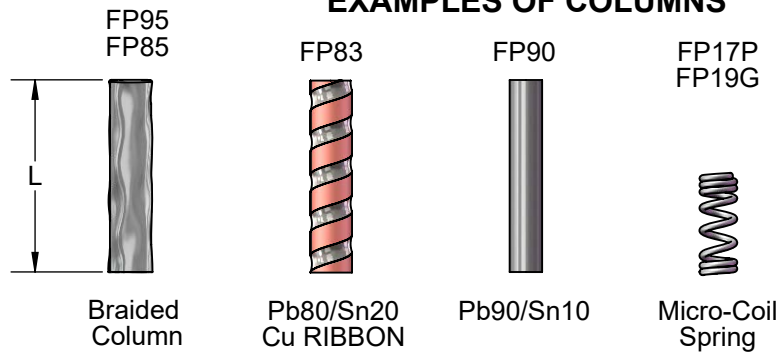

NOTE: COLUMN TO BE TRIMMED TO 2.21mm AFTER ATTACHMENT.

TopLine®

TITLE FP1291A FLIP-PACK®
CCGA COLUMN CARRIER

SCALE	SIZE	DRAWING NO.	REV
10:1	A	001361	A

DO NOT SCALE DRAWING

SHEET 8 OF 11

FLIP-PACK® DRAWING NUMBERING SYSTEM

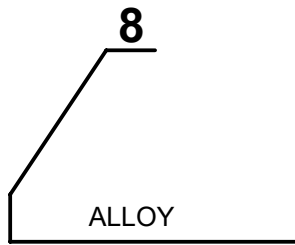

Code	Description
00	Empty
1	Micro-Coil
8	Pb80/Sn20
9	Pb90/Sn10

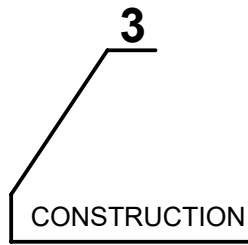

Code	Description
0	Plain Wire
3	Cu Ribbon
5	Braided Column
7	Micro-Coil SnPb
9	Micro-Coil Au

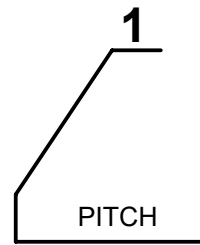

Code	Pitch
1	1.0mm

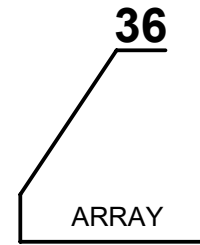

Code	Matrix
36	36x36

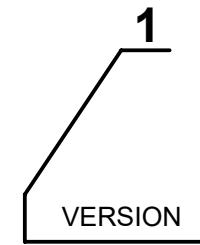

Code	Rev
1	∅0.51mm L=2.36mm

EXAMPLES OF COLUMNS

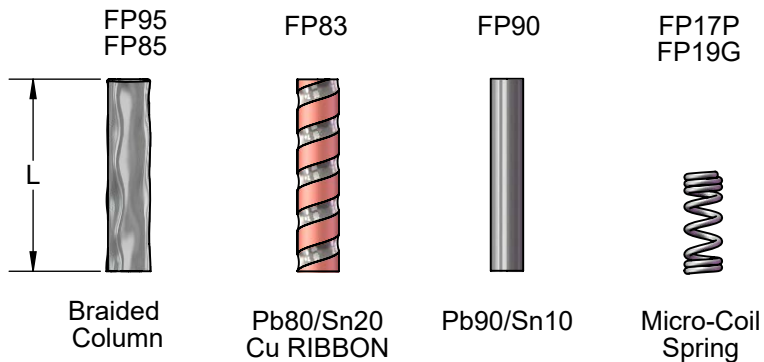

TopLine®			
TITLE FP1291A FLIP-PACK® CCGA COLUMN CARRIER			
SCALE	SIZE	DRAWING NO.	REV
10:1	A	001361	A
DO NOT SCALE DRAWING			SHEET 9 OF 11

HARDWARE PLASTIC KNURLED HEAD THUMB SCREW

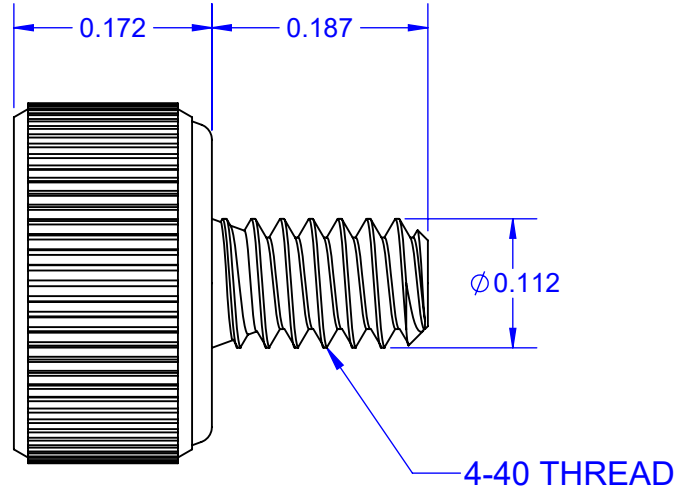
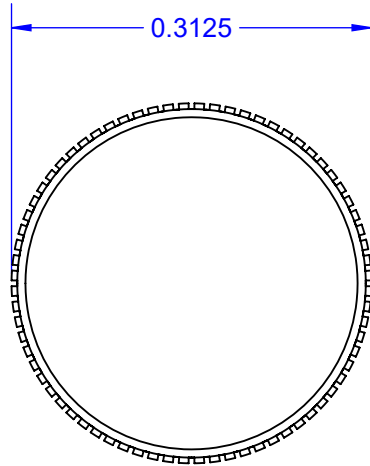

MODELS

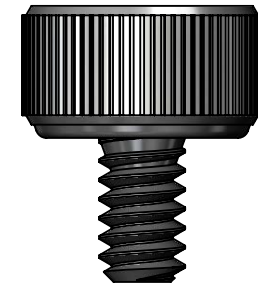
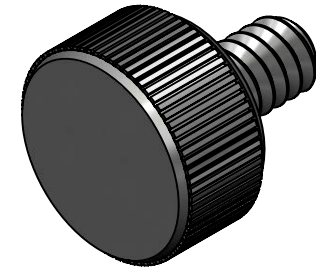

- NOTES:
1. DIMENSIONS INCHES (UNLESS OTHERWISE SPECIFIED).
 2. SHAFT MATERIAL 18-8 STAINLESS STEEL.
 3. HEAD: PLASTIC.
 4. COLOR: BLACK.

DRILL TABLE

HEAD COLOR	THREAD	MAX OD	TAP DRILL Start Hole	CL HOLE Loose Fit	L SHAFT	DWG
BLACK	4-40	0.112"	0.089"	0.136"	0.187	704018

TopLine®

TITLE KNURL THUMB SCREW 4-40 PLASTIC HEAD			
SCALE 6:1	SIZE A	DRAWING NO. 704018	REV A

DO NOT SCALE DRAWING

SHEET 10 OF 11

BUTTON HEAD SCREW

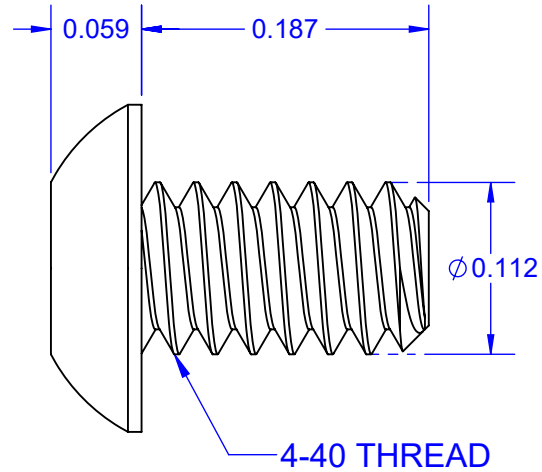
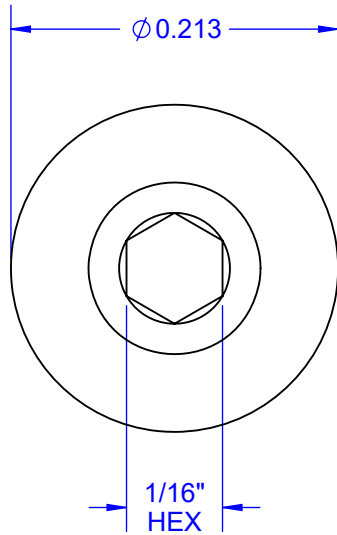

MODELS

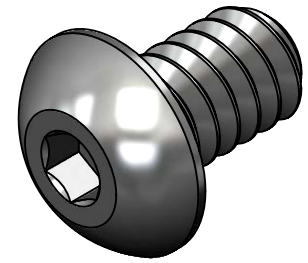

- NOTES: (UNLESS OTHERWISE SPECIFIED)
 1. DIMENSIONS INCHES.
 2. MATERIAL: SEE TABLE.
 3. COLOR: SEE TABLE.

DRILL TABLE						
MATERIAL	COLOR	THREAD	MAX OD	TAP DRILL Start Hole	L	DWG
8-18	STAINLESS	4-40	0.112"	0.089"	0.187"	704035

			
TITLE BUTTON HEAD CAP SCREW 4-40x .187" (1/16 HEX)			
SCALE 8:1	SIZE A	DRAWING NO. 704035	REV A
DO NOT SCALE DRAWING			SHEET 11 OF 11