

ASSEMBLY EXPLODED VIEW

U.S. PATENT No.
9,108,262 and 9,629,259

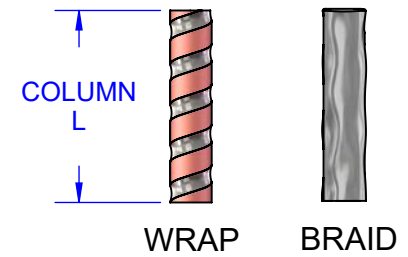

DIMENSION TABLE			
H	L MAX	W	DWG
4.02mm 0.158"	2.54mm 0.100"	1.82mm 0.072"	120254

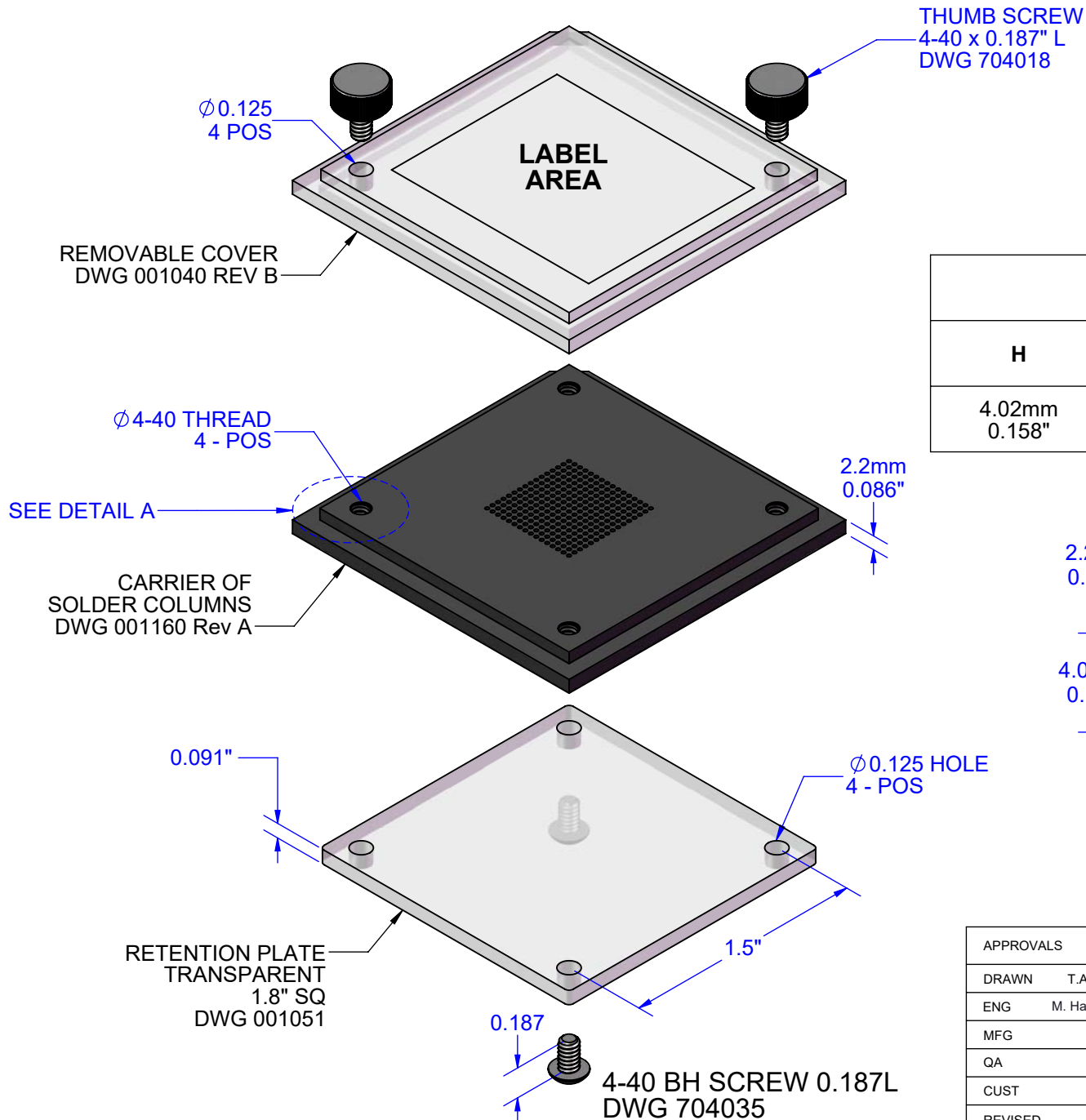
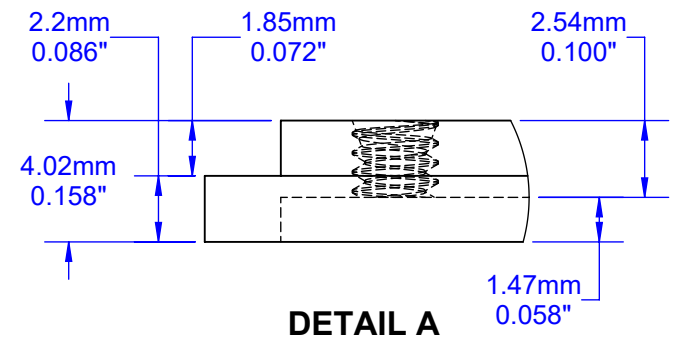

APPROVALS	DATE	TopLine®			
DRAWN T. Au	7/23/2024				
ENG M. Hart	7/23/2024	TITLE FP256A FLIP PACK® CCGA COLUMN CARRIER			
MFG		SCALE 1.25:1	SIZE A	DRAWING NO. 001160	REV A
QA		DO NOT SCALE DRAWING			SHEET 1 OF 11
CUST					
REVISED					

SIDE

TOP VIEW

TOP VIEW

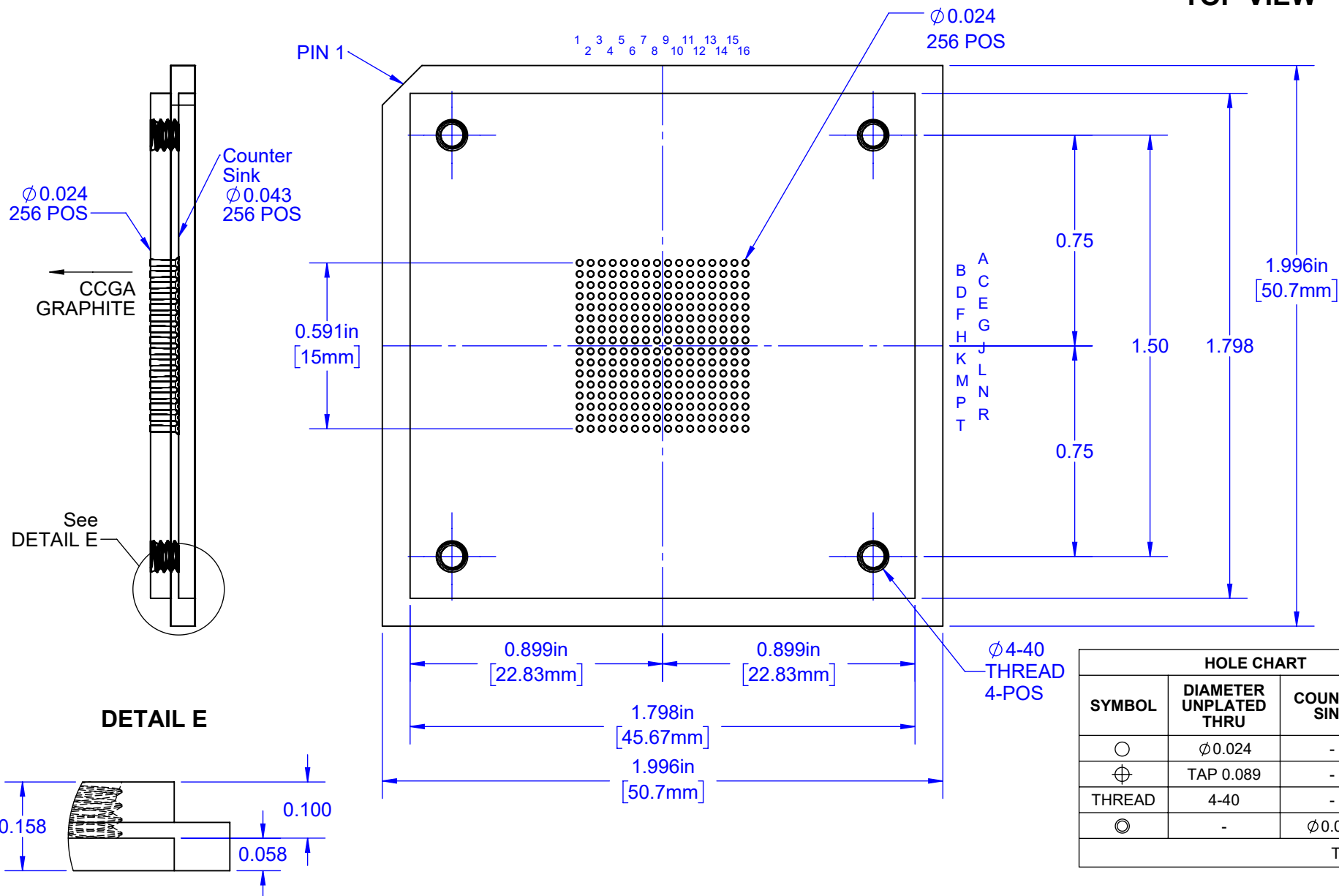

HOLE CHART			
SYMBOL	DIAMETER UNPLATED THRU	COUNTER SINK	QTY
○	Ø0.024	-	256
⊕	TAP 0.089	-	4
THREAD	4-40	-	4
◎	-	Ø0.043	256
TOTAL			516

TopLine®

TITLE FP256A FLIP PACK @ CCGA COLUMN CARRIER

SCALE 2:1	SIZE A	DRAWING NO. 001160	REV A
-----------	--------	--------------------	-------

DO NOT SCALE DRAWING SHEET 3 OF 11

Notes: (Unless Otherwise Specified).
 1) MATERIAL: BLACK PLASTIC, CONDUCTIVE.
 2) DIMENSIONS : INCHES [MM].

DETAIL D WITH COVER PLATE

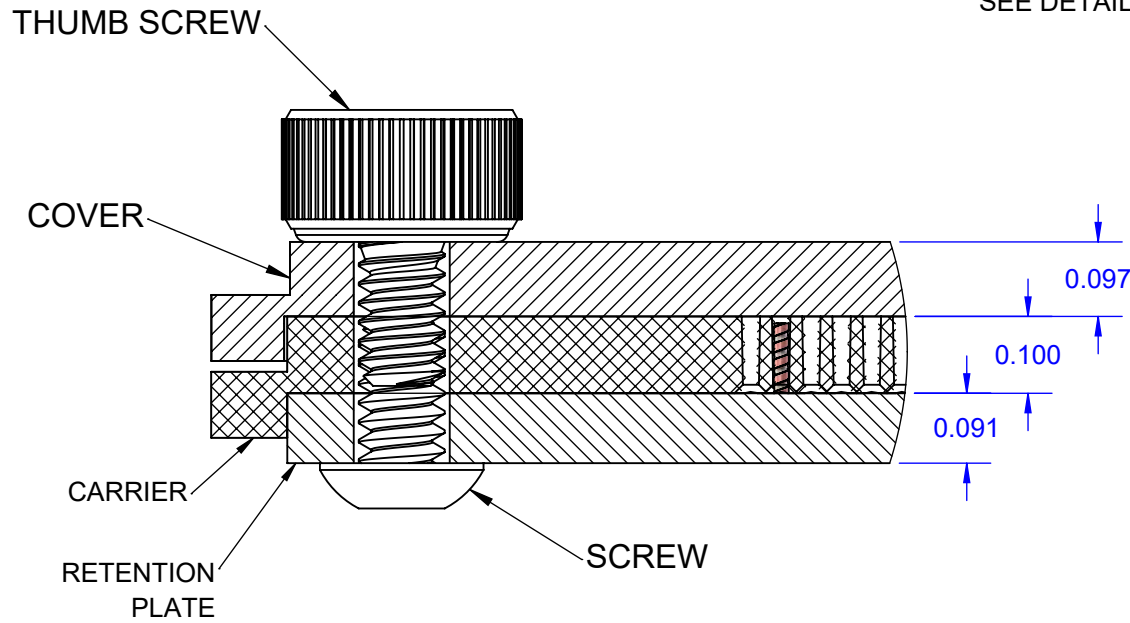

SEE DETAIL D

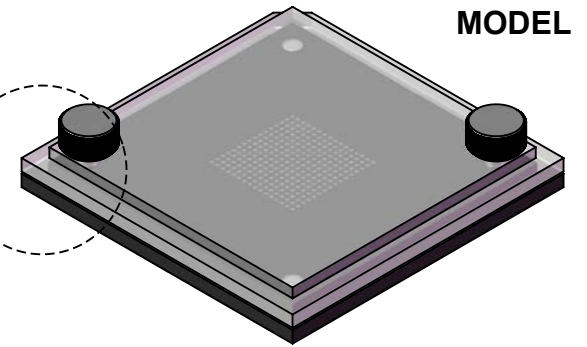

EXAMPLE OF COLUMNS

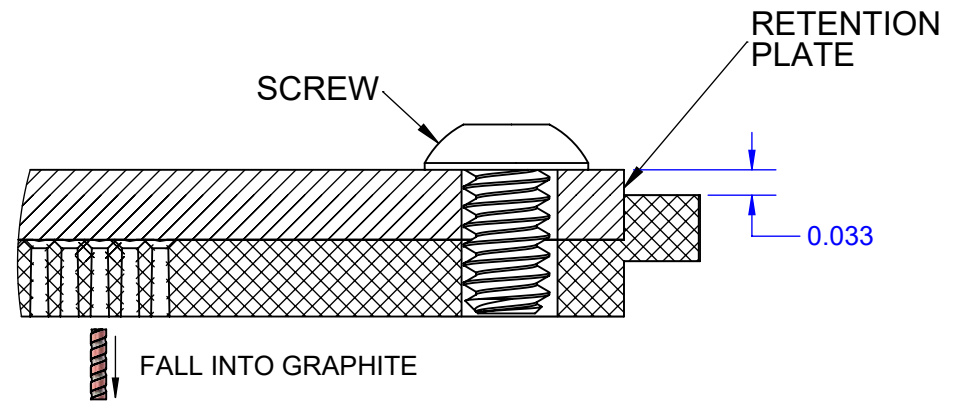
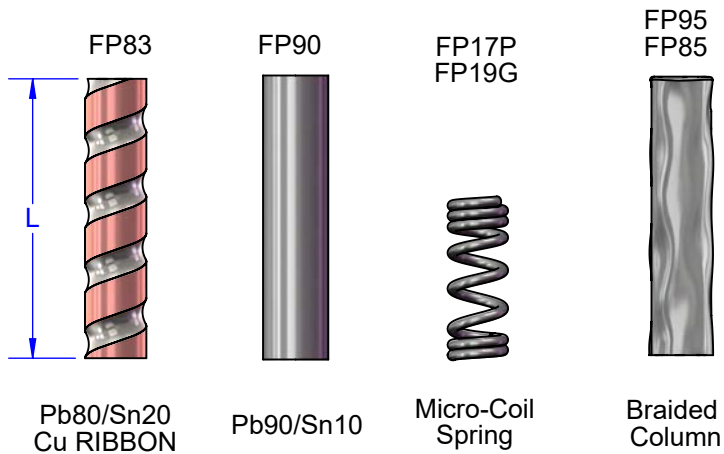

TopLine®

TITLE FP256A FLIP PACK @
CCGA COLUMN CARRIER

SCALE 4:1	SIZE A	DRAWING NO. 001160	REV A
--------------	-----------	-----------------------	----------

DO NOT SCALE DRAWING

SHEET 4 OF 11

FLIP PACK® MODEL

COVER 001040 REV B

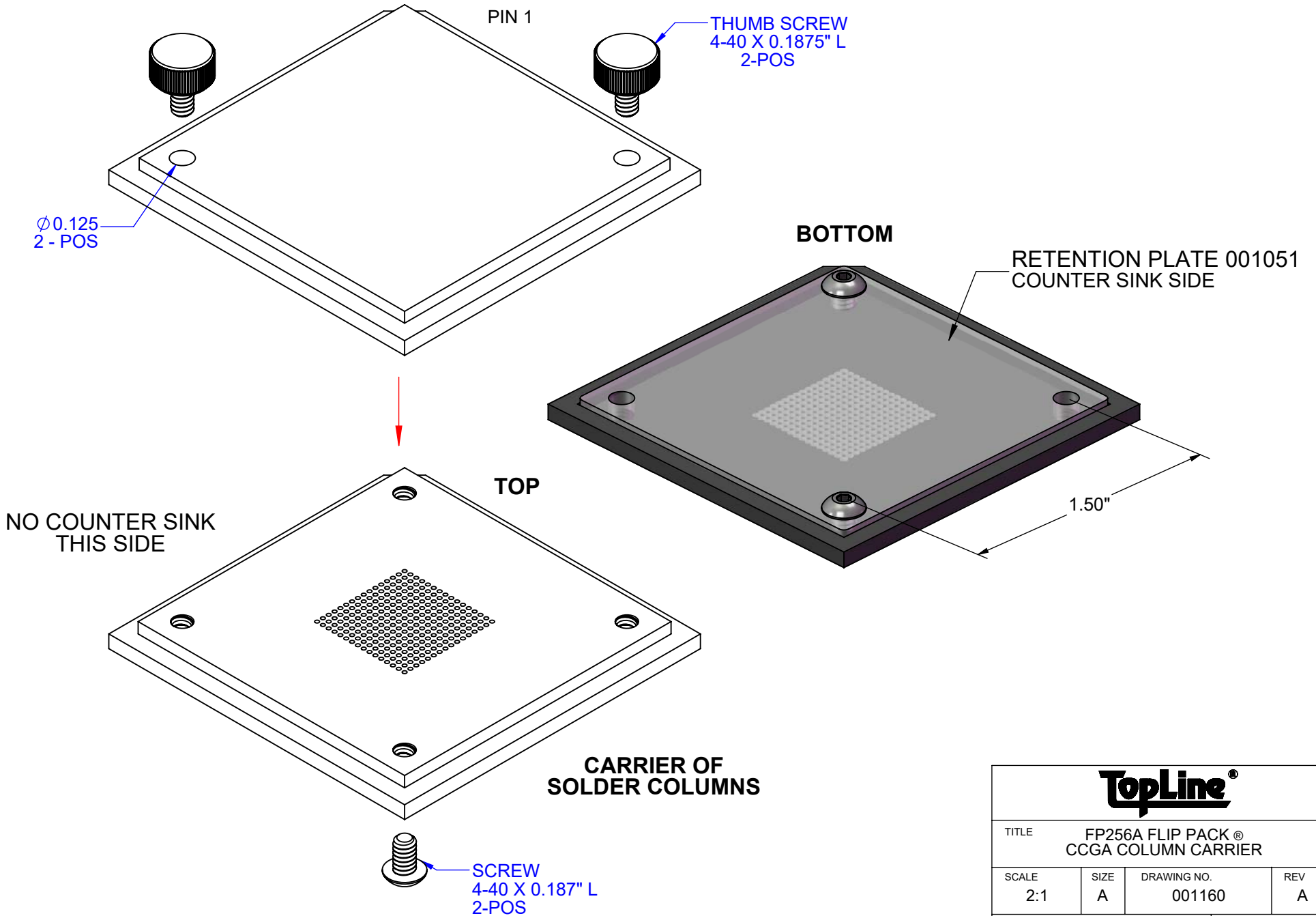

TopLine®

TITLE FP256A FLIP PACK®
CCGA COLUMN CARRIER

SCALE	SIZE	DRAWING NO.	REV
2:1	A	001160	A

DO NOT SCALE DRAWING

SHEET 5 OF 11

BOTTOM RETENTION PLATE

SIDE VIEW

TOP VIEW

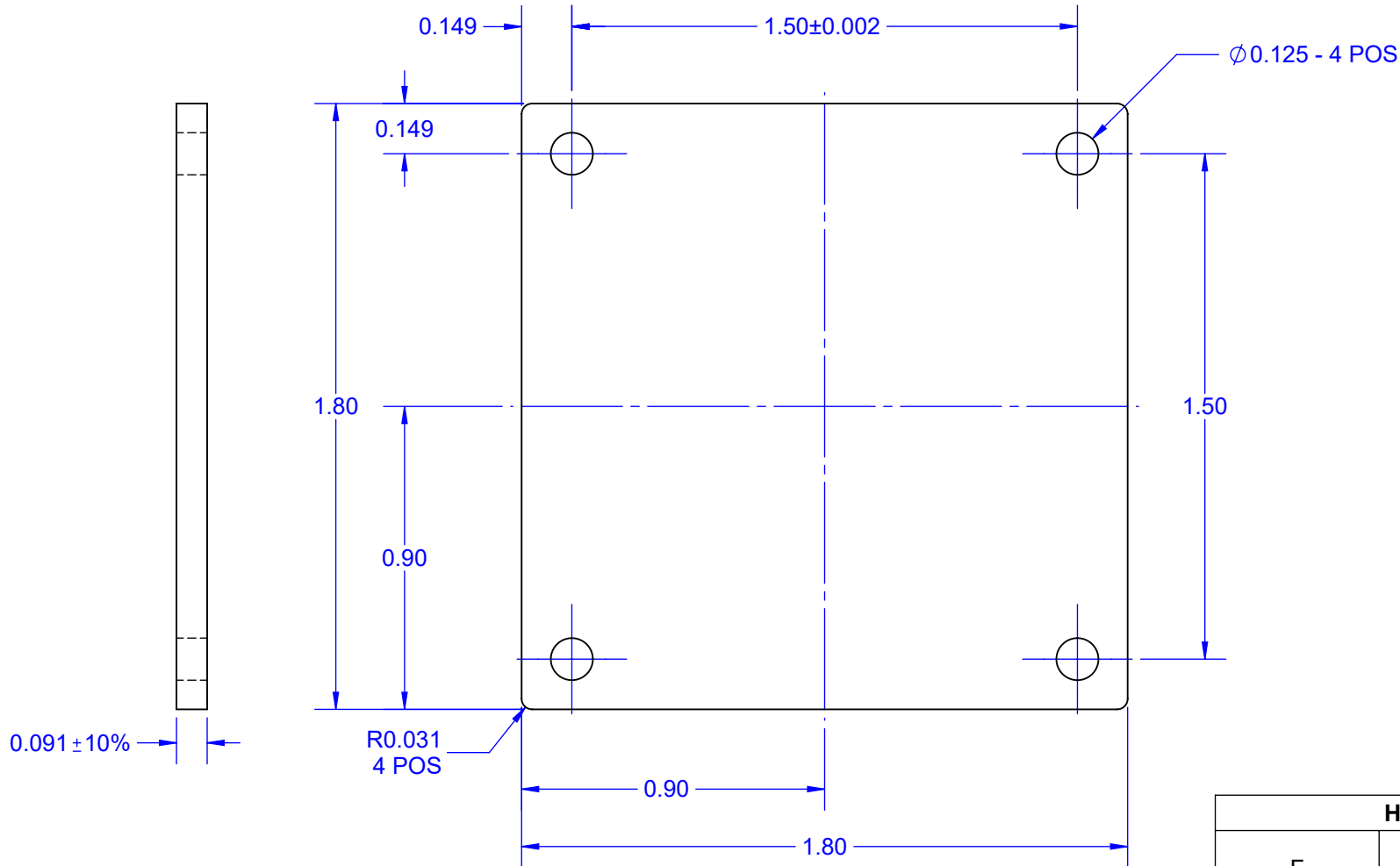

HOLE CHART		
F	DIAMETER UNPLATED	QTY HOLES
+	$\phi 0.125$	4

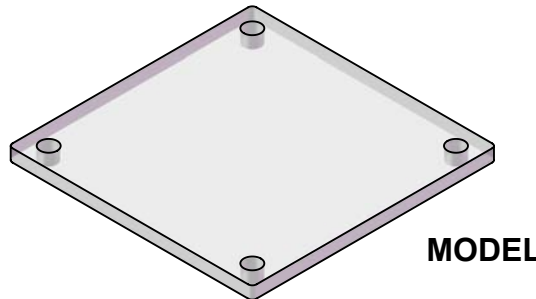

MODEL

NOTES: (Unless Otherwise Specified).

- 1) DIMENSIONS INCH.
- 2) MATERIAL: CLEAR PC-300 POLYCARBONATE.
- 3) STATIC DISIPATIVE $10^6 \sim 10^8 \Omega$. (ESD SAFE).
- 4) HOLE BREAK OUT ALLOWED.

TITLE FP1.8-BOTTOM-1.5B BOTTOM RETENTION PLATE			
SCALE 2:1	SIZE A	DRAWING NO. 001051	REV A
DO NOT SCALE DRAWING			SHEET 6 OF 11

COVER 001040 REV B

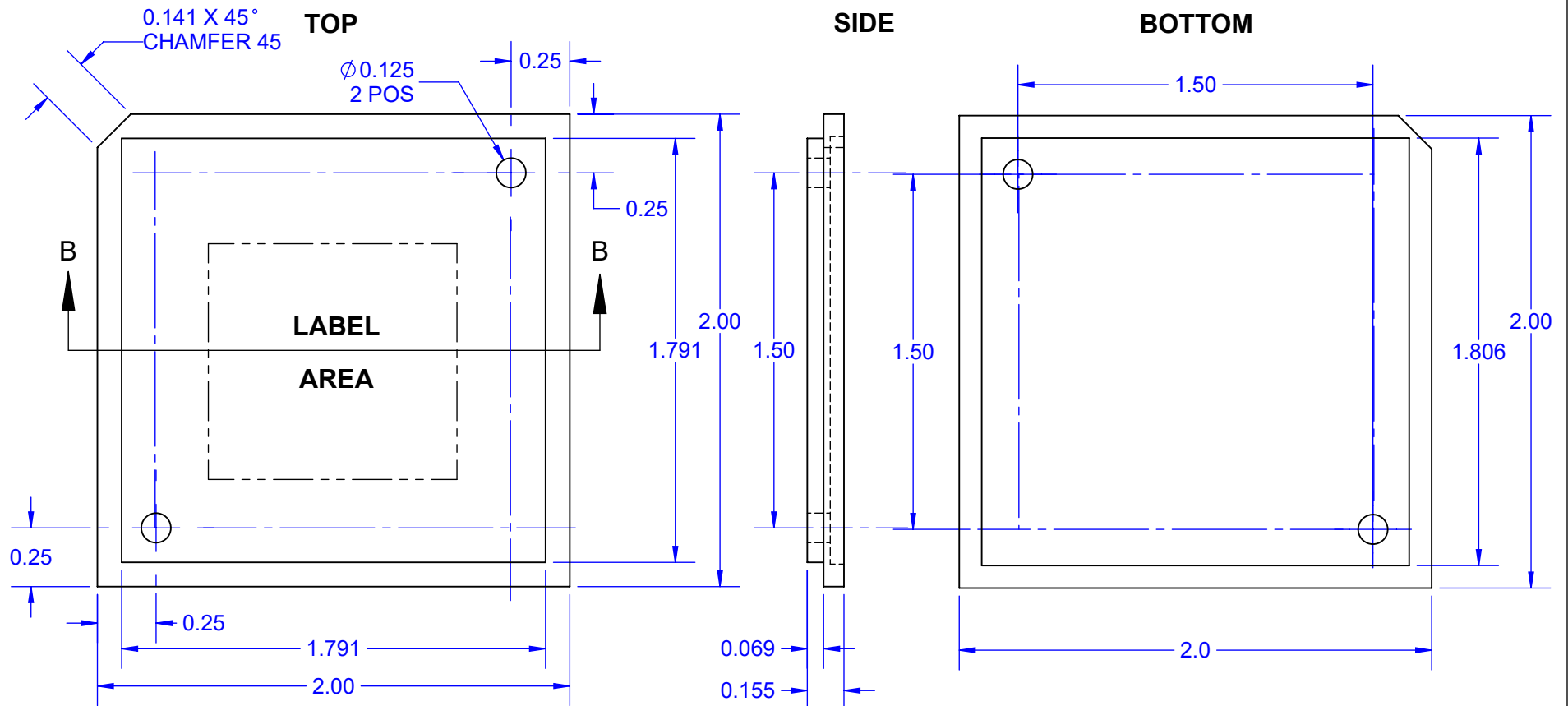

HOLE CHART		
SYMBOL	DIAMETER UNPLATED	QTY HOLES
+	Ø0.125	2

- Notes: (Unless Otherwise Specified).
- 1) DIMENSIONS: INCH.
 - 2) MATERIAL: TRANSPARENT PMMA PLASTIC.
 - 3) ANTISTATIC: $10^{12} \Omega$ SURFACE RESISTANCE.

TopLine®			
TITLE FLIP-PACK® TOP COVER 2-INCH 1.50 SPACE			
SCALE 3:2	SIZE A	DRAWING NO. 001040	REV B
DO NOT SCALE DRAWING			SHEET 7 OF 11

FLIP-PACK® PART NUMBERING SYSTEM

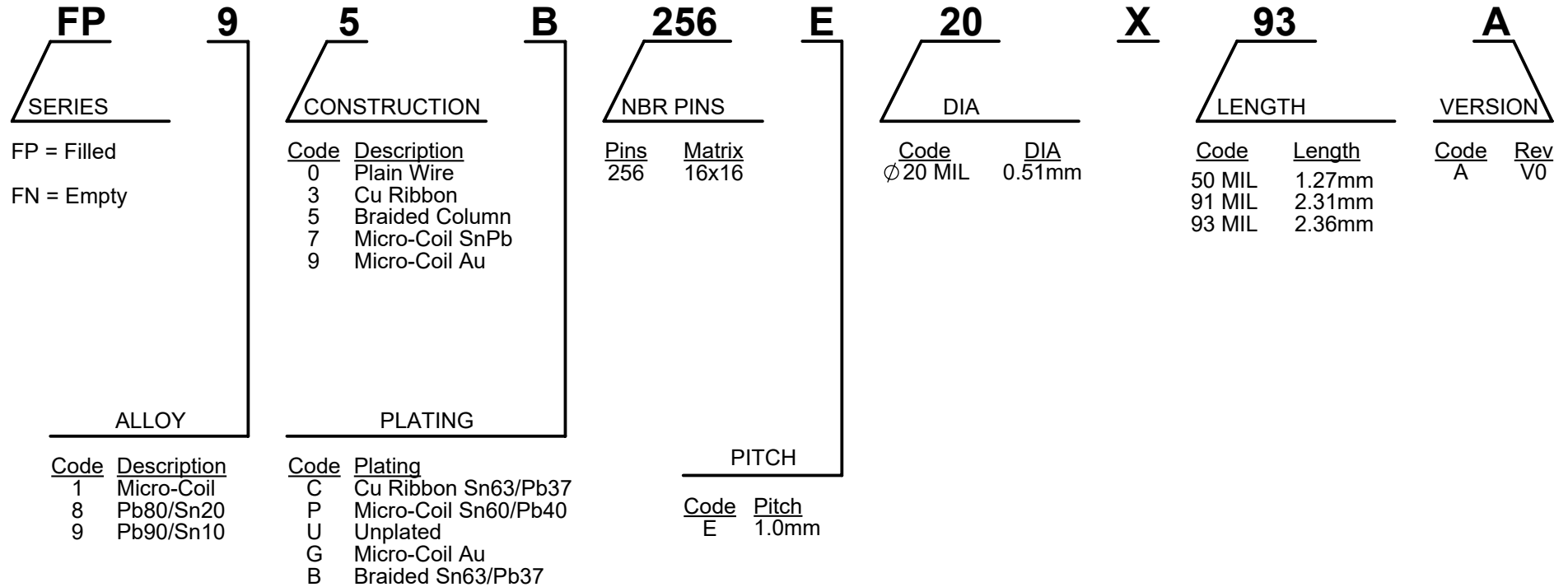

EXAMPLES OF COLUMNS

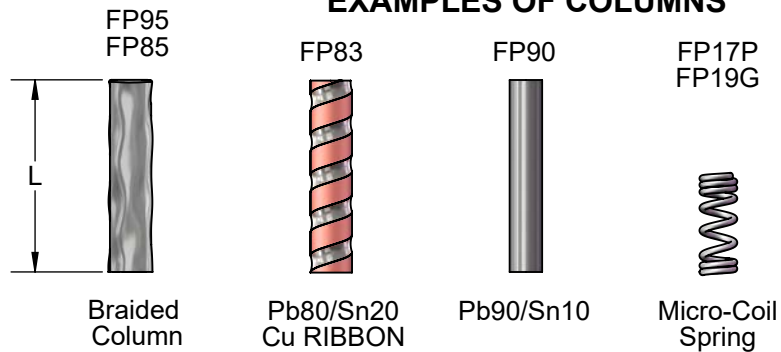

NOTE: COLUMN TO BE TRIMMED TO 2.21mm AFTER ATTACHMENT.

TITLE FP256A FLIP PACK® CCGA COLUMN CARRIER			
SCALE 10:1	SIZE A	DRAWING NO. 001160	REV A
DO NOT SCALE DRAWING			SHEET 8 OF 11

FLIP-PACK® DRAWING NUMBERING SYSTEM

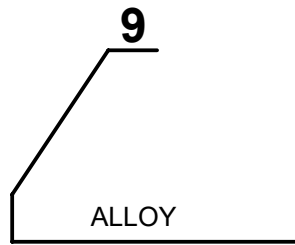

Code	Description
00	Empty
1	Micro-Coil
8	Pb80/Sn20
9	Pb90/Sn10

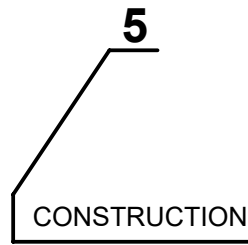

Code	Description
0	Plain Wire
3	Cu Ribbon
5	Braided Column
7	Micro-Coil SnPb
9	Micro-Coil Au

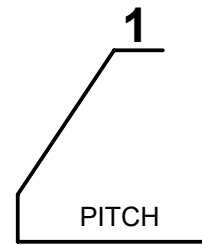

Code	Pitch
1	1.0mm

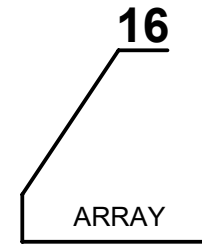

Code	Matrix
16	16x16

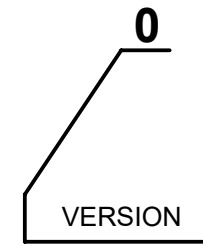

Code	Rev
0	∅0.51mm L=2.36mm

EXAMPLES OF COLUMNS

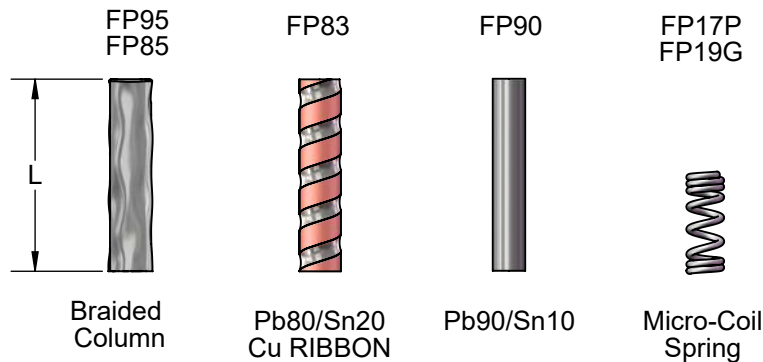

TopLine®			
TITLE FP256A FLIP PACK® CCGA COLUMN CARRIER			
SCALE 10:1	SIZE A	DRAWING NO. 001160	REV A
DO NOT SCALE DRAWING			SHEET 9 OF 11

HARDWARE PLASTIC KNURLED HEAD THUMB SCREW

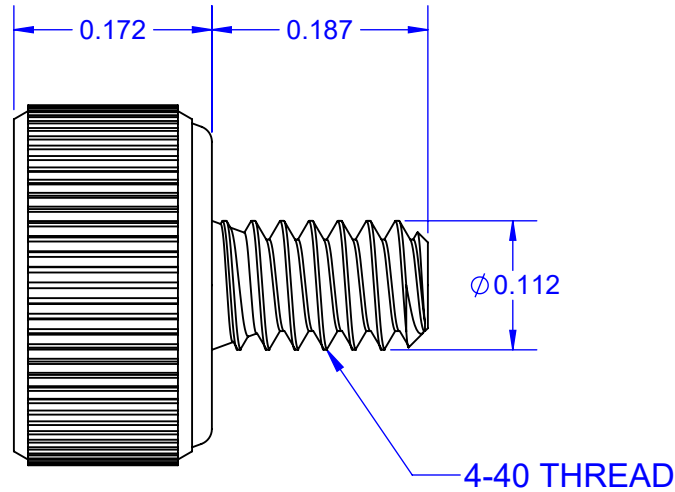
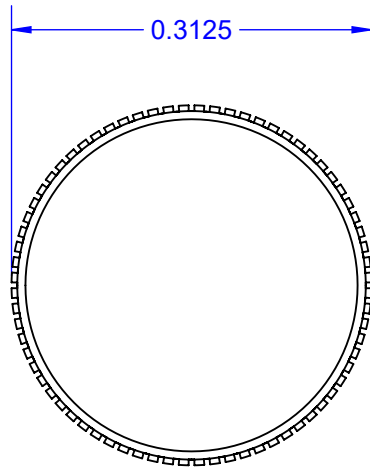

MODELS

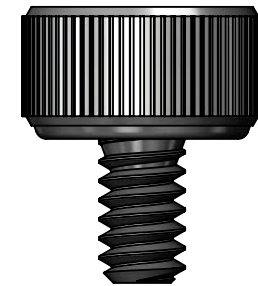
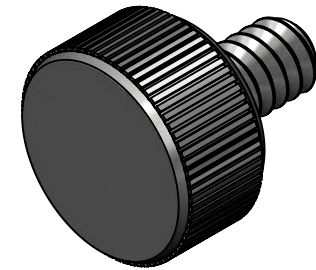

- NOTES:**
1. DIMENSIONS INCHES (UNLESS OTHERWISE SPECIFIED).
 2. SHAFT MATERIAL 18-8 STAINLESS STEEL.
 3. HEAD: PLASTIC.
 4. COLOR: BLACK.

DRILL TABLE

HEAD COLOR	THREAD	MAX OD	TAP DRILL Start Hole	CL HOLE Loose Fit	L SHAFT	DWG
BLACK	4-40	0.112"	0.089"	0.136"	0.187	704018

TopLine®

TITLE KNURL THUMB SCREW
4-40 PLASTIC HEAD

SCALE 6:1	SIZE A	DRAWING NO. 704018	REV A
--------------	-----------	-----------------------	----------

DO NOT SCALE DRAWING

SHEET 10 OF 11

BUTTON HEAD SCREW

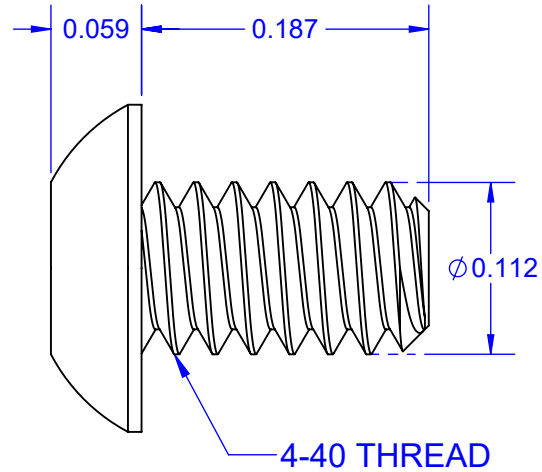
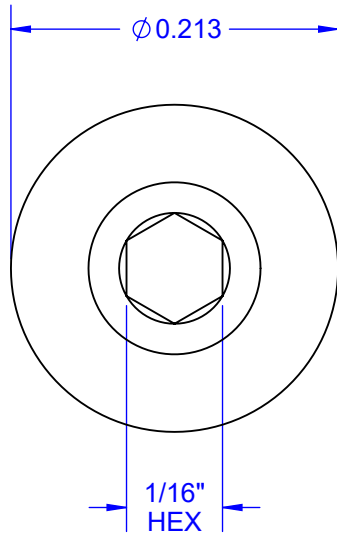

MODELS

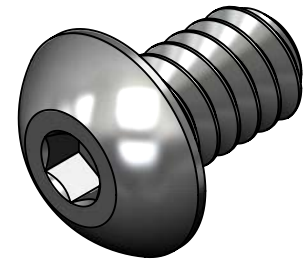

- NOTES: (UNLESS OTHERWISE SPECIFIED)
 1. DIMENSIONS INCHES.
 2. MATERIAL: SEE TABLE.
 3. COLOR: SEE TABLE.

DRILL TABLE						
MATERIAL	COLOR	THREAD	MAX OD	TAP DRILL Start Hole	L	DWG
8-18	STAINLESS	4-40	0.112"	0.089"	0.187"	704035

			
TITLE BUTTON HEAD CAP SCREW 4-40x .187" (1/16 HEX)			
SCALE 8:1	SIZE A	DRAWING NO. 704035	REV A
DO NOT SCALE DRAWING			SHEET 11 OF 11