

SIDE

TOP VIEW

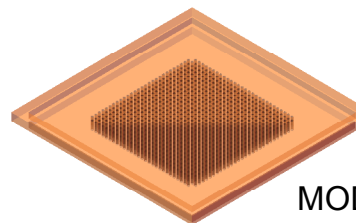
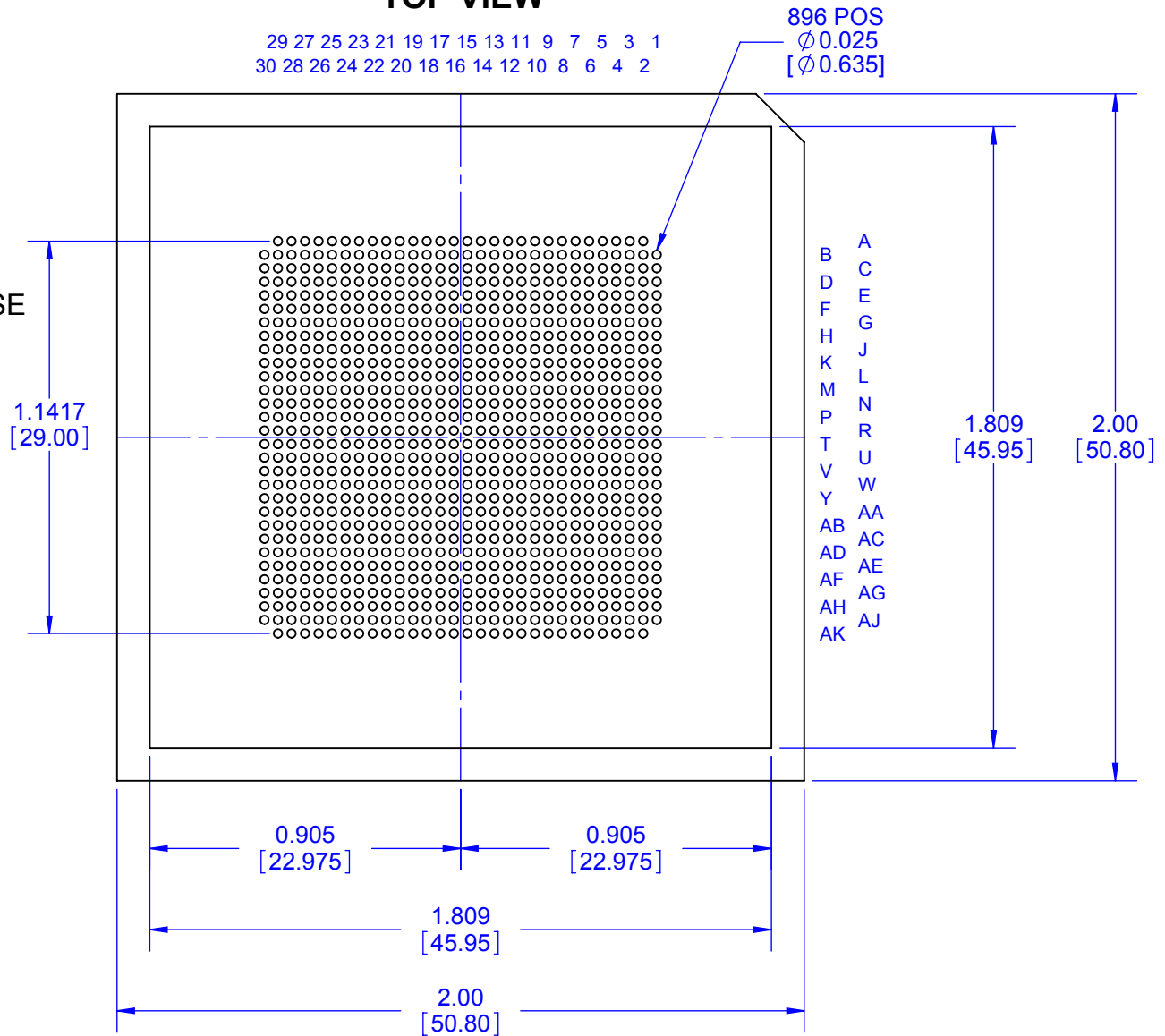
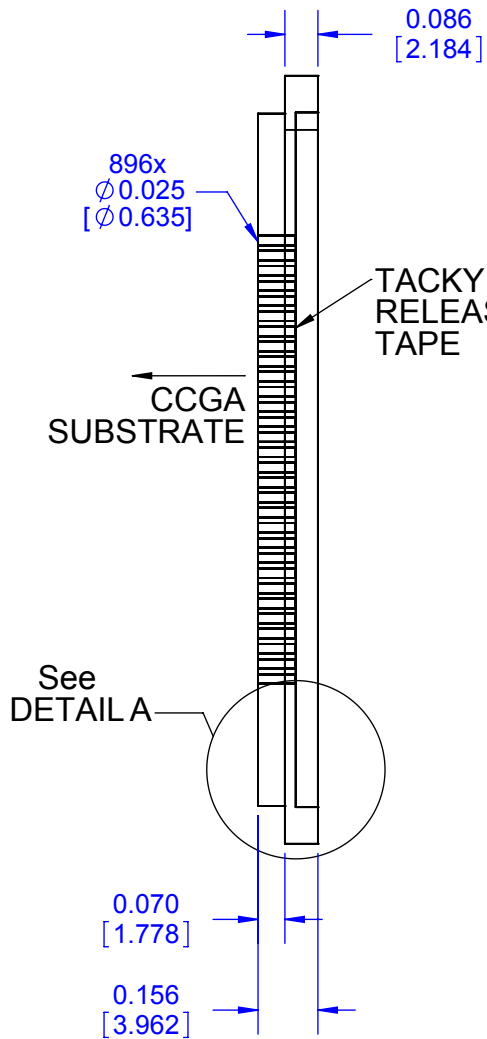

MODEL

NOTES:
1. DIMENSIONS INCHES [MM].
2. SHOWN WITH MAXIMUM ARRAY.

TopLine®			
TITLE PP896 PIN-PACK™ CCGA COLUMN CARRIER			
SCALE 2:1	SIZE A	DRAWING NO. 001300	REV A
DO NOT SCALE DRAWING			SHEET 1 OF 8

DETAIL A

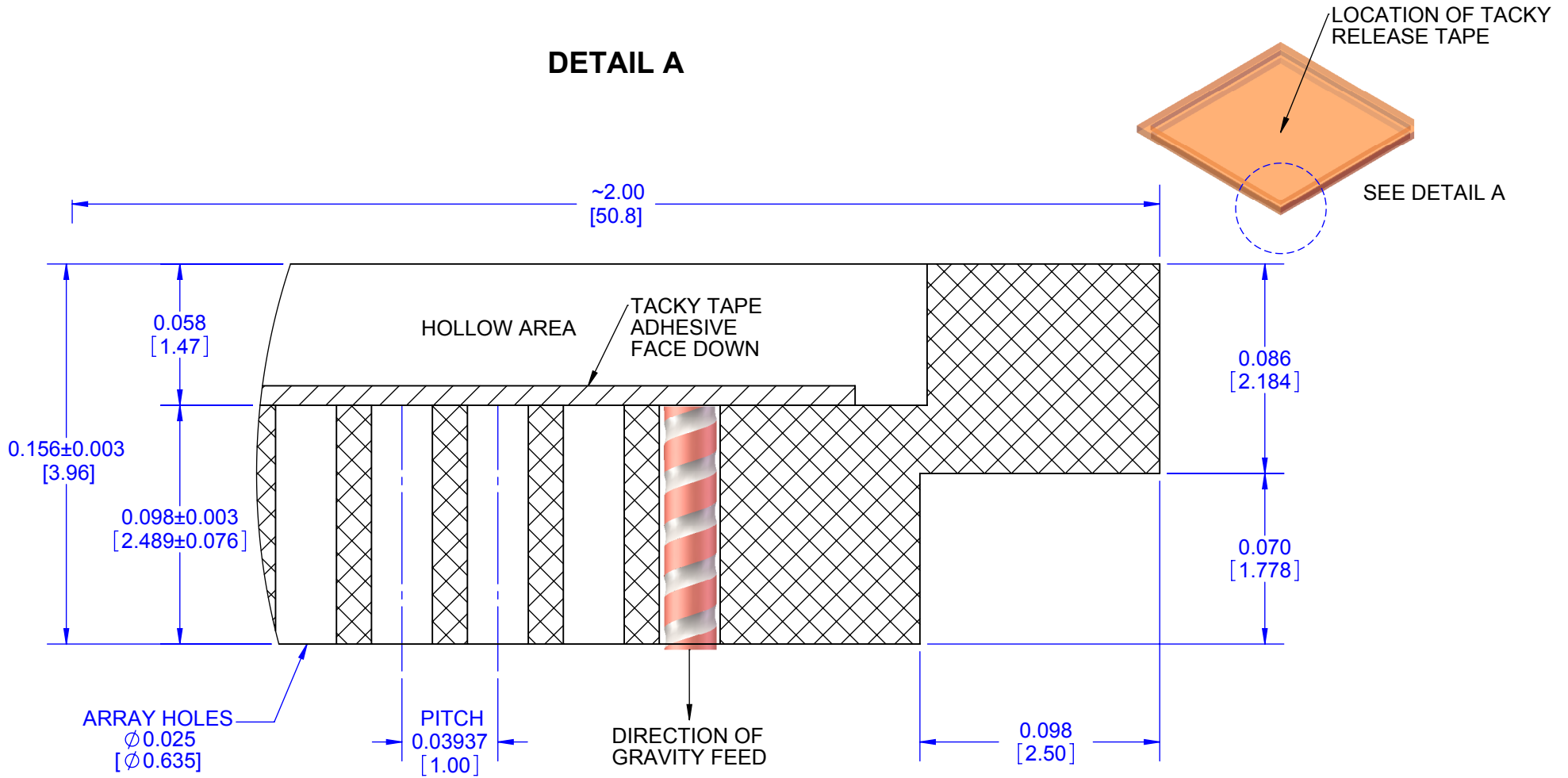

EXAMPLES OF COLUMNS

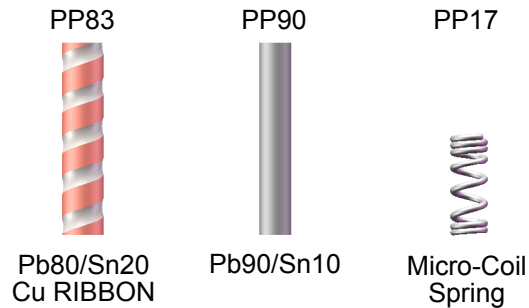

NOTES:
1. DIMENSIONS INCHES [MM].

TopLine®			
TITLE PP896 PIN-PACK™ CCGA COLUMN CARRIER			
SCALE	SIZE	DRAWING NO.	REV
16:1	A	001300	A
DO NOT SCALE DRAWING			SHEET 2 OF 8

PART NUMBER TABLE

PIN-PACK™	Pins	Pitch	Matrix	COLUMN				Empty DWG	Filled DWG
				Alloy	Construction	∅ Dia	Length		
PP83C896E20x100A PP90U896E20x100A PP17P896E20x50A	896	1.0mm	30x30	Pb80 Pb90 MCS	Cu Ribbon Plain Micro Coil	0.51mm	2.54mm 2.54mm 1.27mm	001300	831300 901300 171300

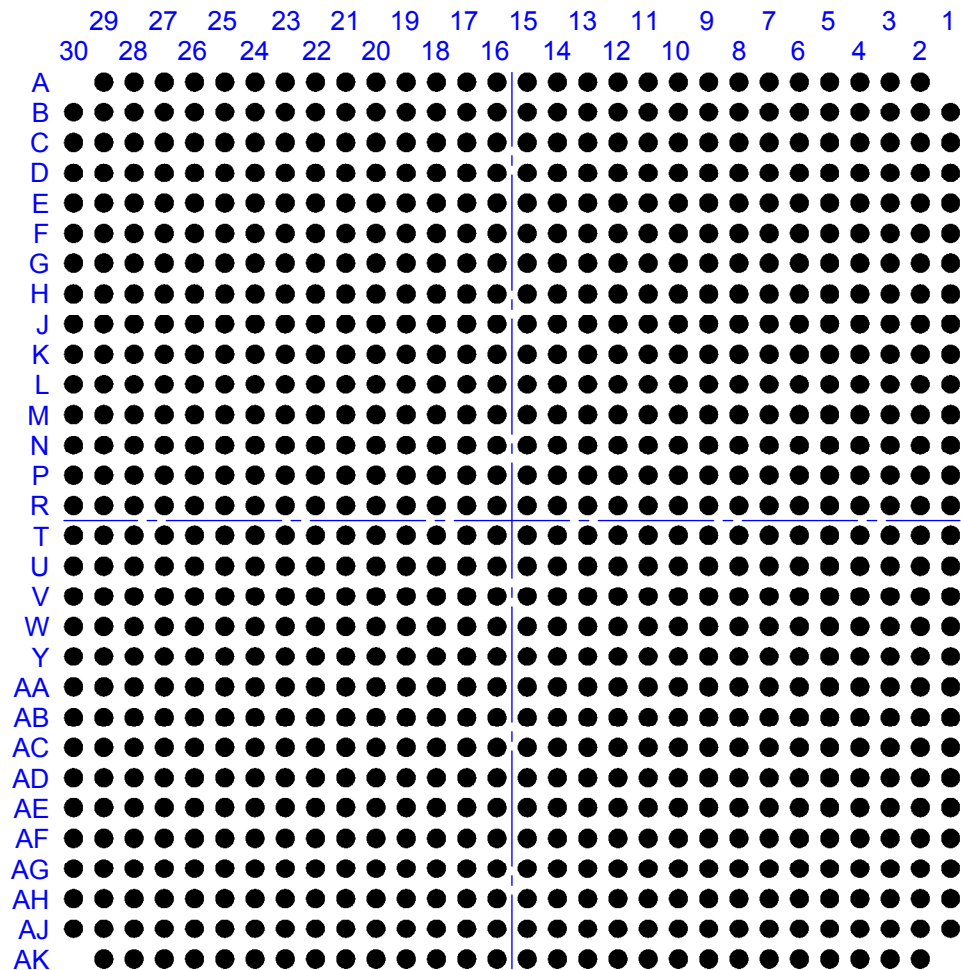

NOTE: DEPOPULATED A1, A30, AK1, AK30.

EXAMPLES OF COLUMNS

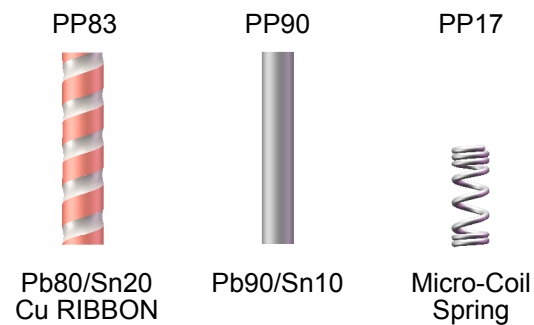

TITLE			
PP896 PIN-PACK™ CCGA COLUMN CARRIER			
SCALE	SIZE	DRAWING NO.	REV
NONE	A	001300	A
DO NOT SCALE DRAWING			SHEET 3 OF 8

PIN-PACK™ PART NUMBERING SYSTEM

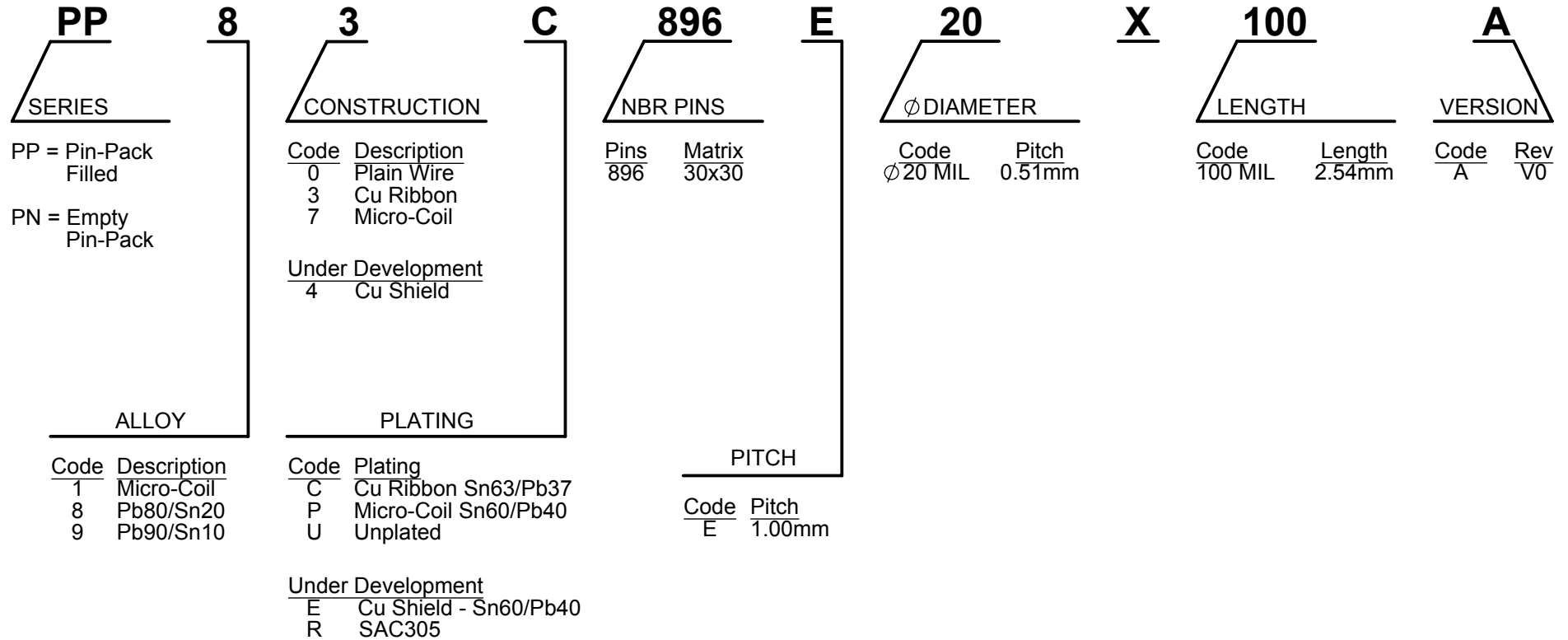

EXAMPLES OF COLUMNS

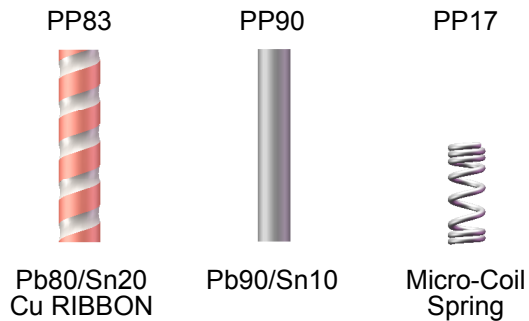

NOTE 1: PP83, PP90 and PP93 REQUIRES TRIMMING TO FINISHED LENGTH.
 NOTE 2: COLUMN 2.54mm TO BE TRIMMED TO 2.21mm AFTER ATTACHMENT.

TopLine®			
TITLE PP896 PIN-PACK™ CCGA COLUMN CARRIER			
SCALE 10:1	SIZE A	DRAWING NO. 001300	REV A
DO NOT SCALE DRAWING			SHEET 4 OF 8

PIN-PACK™ DRAWING NUMBERING SYSTEM

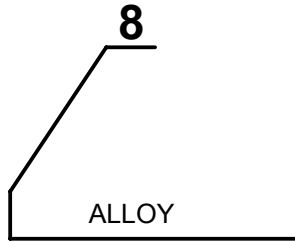

Code	Description
00	Empty
1	Micro-Coil
8	Pb80/Sn20
9	Pb90/Sn10

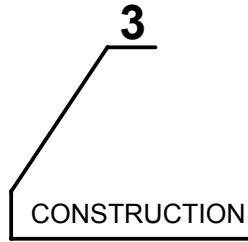

Code	Description
0	Plain Wire
3	Cu Ribbon
7	Micro-Coil

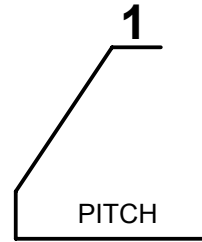

Code	Pitch
1	1.0mm

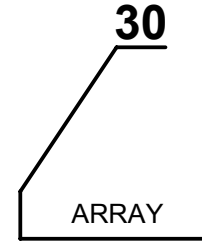

Code	Matrix
30	30x30

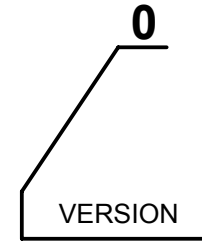

Code	Rev
0	896 PINS

Under Development

4	Cu + Sn60/Pb40
5	Cu + SAC
6	Sn60/Pb40

EXAMPLES OF COLUMNS

PP83



Pb80/Sn20
Cu RIBBON

PP90



Pb90/Sn10

PP17



Micro-Coil
Spring

TopLine®

TITLE PP896 PIN-PACK™
CCGA COLUMN CARRIER

SCALE	SIZE	DRAWING NO.	REV
10:1	A	001300	A

DO NOT SCALE DRAWING

SHEET 5 OF 8

PIN-PACK™ OUTLINE

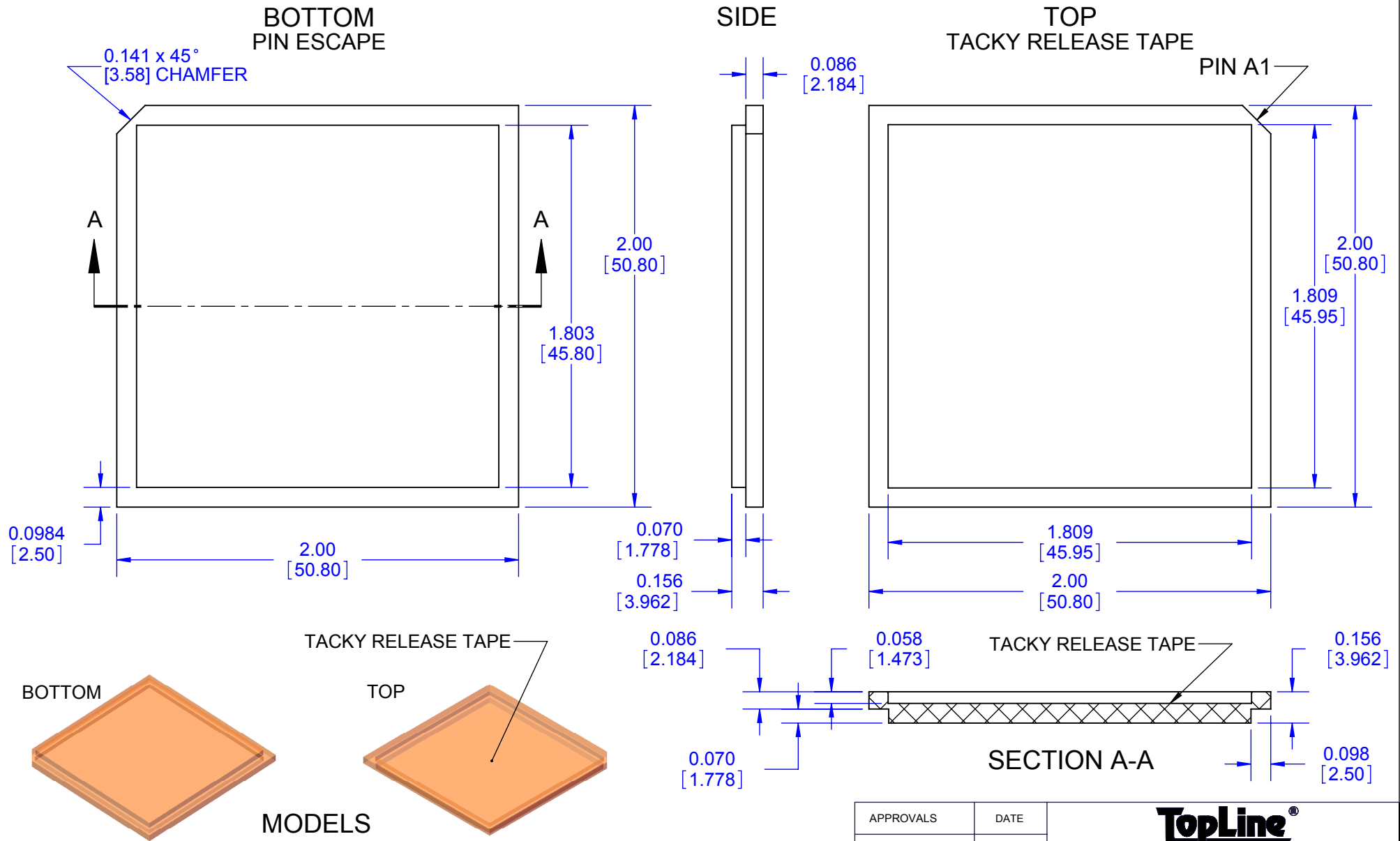

- NOTES:
1. DIMENSIONS INCHES [MM].
 2. SHOWN WITHOUT HOLES FOR CLARITY.
 3. PIN-PACK™ IS TRADEMARK OF TOPLINE.
 4. PIN-PACK™ PATENT PENDING.

APPROVALS	DATE	TopLine®			
DRAWN T.Au	10/02/14				
ENG M. Hart	10/02/14	TITLE PP896 PIN-PACK™ CCGA COLUMN CARRIER			
MFG		SCALE	SIZE	DRAWING NO.	REV
QA		3:2	A	001300	A
CUST		DO NOT SCALE DRAWING			SHEET 6 OF 8
REVISED					

TACKY RELEASE TAPE TOP VIEW

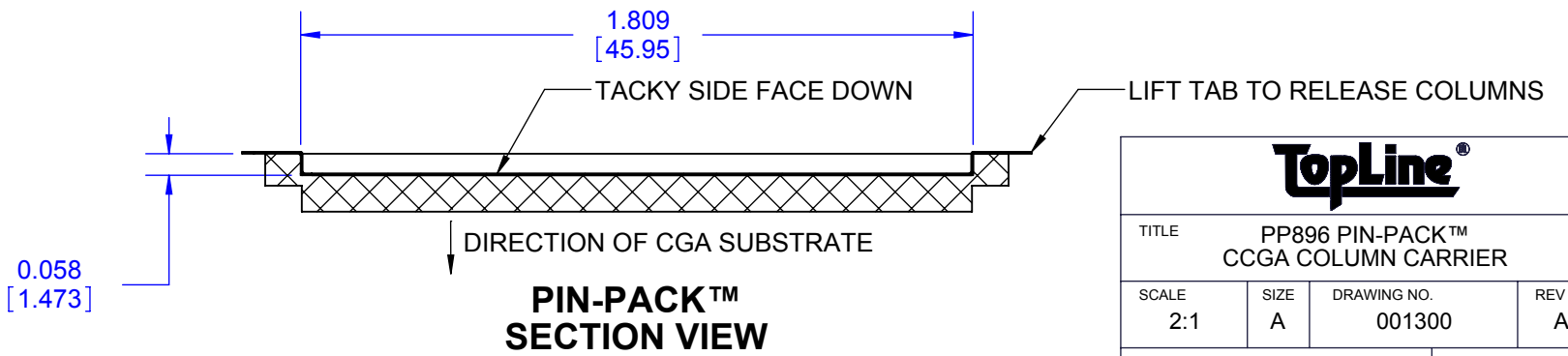
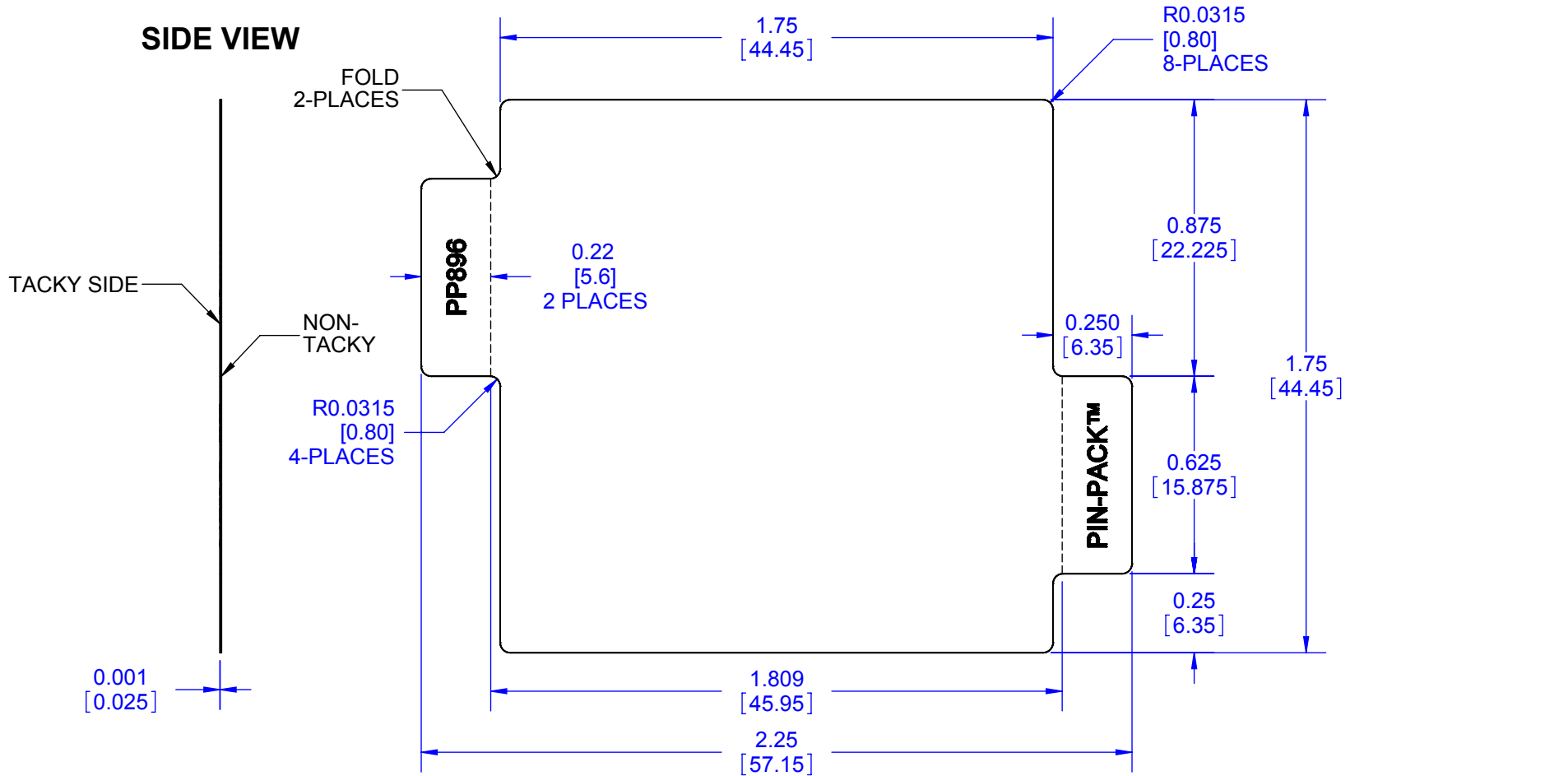

TopLine®			
TITLE PP896 PIN-PACK™ CCGA COLUMN CARRIER			
SCALE 2:1	SIZE A	DRAWING NO. 001300	REV A
DO NOT SCALE DRAWING			SHEET 7 OF 8

TACKY RELEASE TAPE MODEL

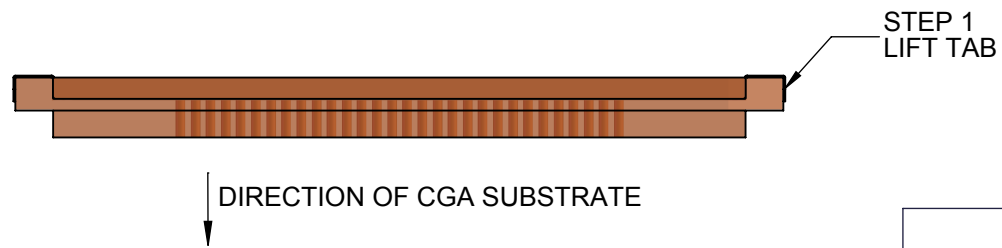
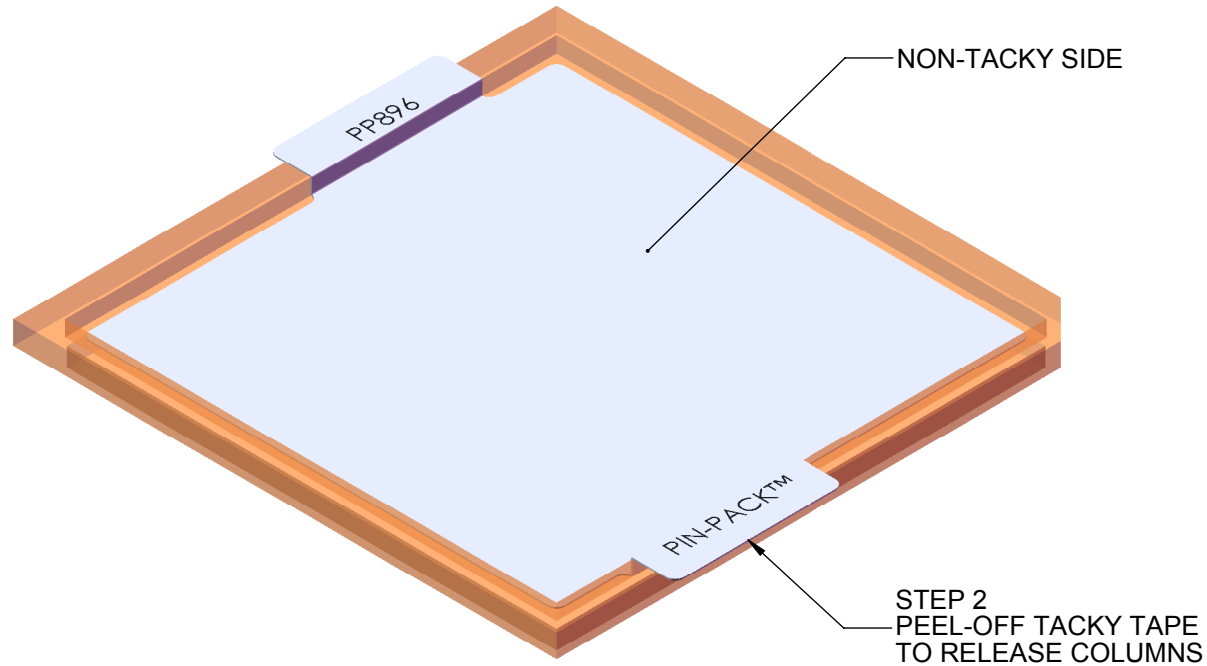

TopLine®			
TITLE PP896 PIN-PACK™ CCGA COLUMN CARRIER			
SCALE 2:1	SIZE A	DRAWING NO. 001300	REV A
DO NOT SCALE DRAWING			SHEET 8 OF 8