

9LH9F=CF`J`9K

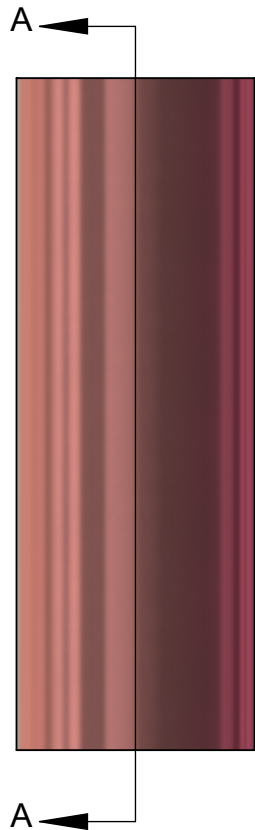

G97H=CB`J`9K

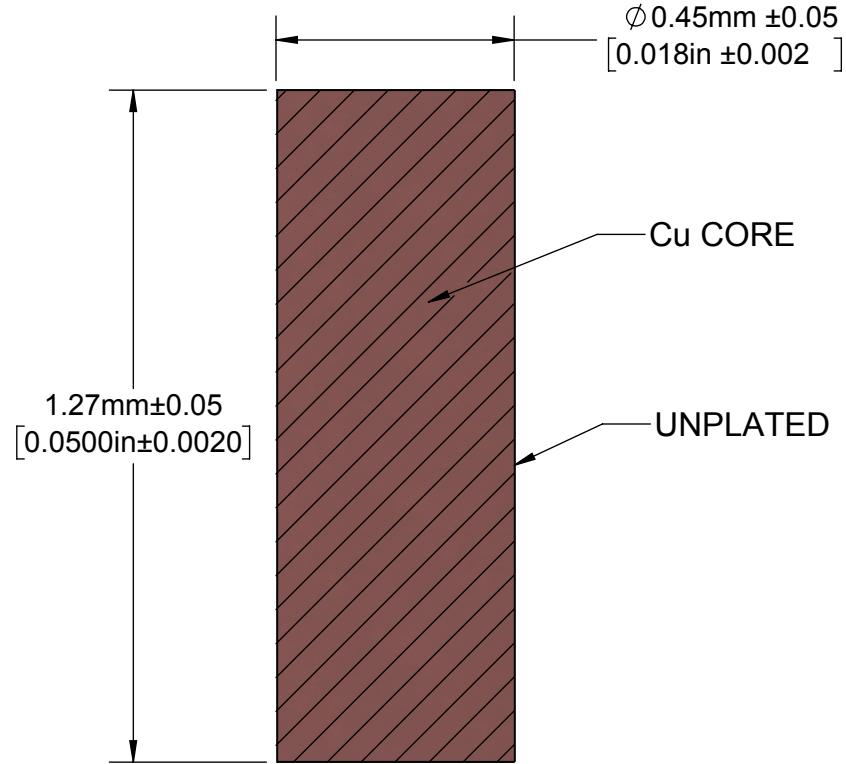

77; 5`!`@ B8`D58

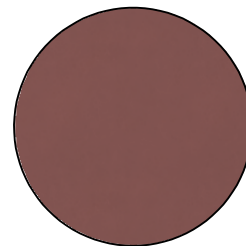
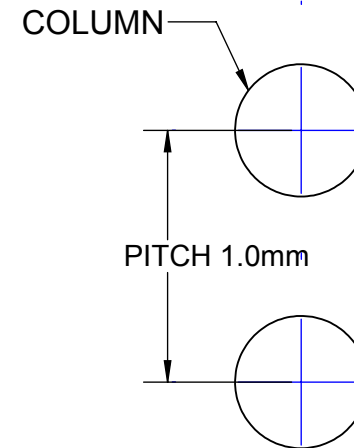
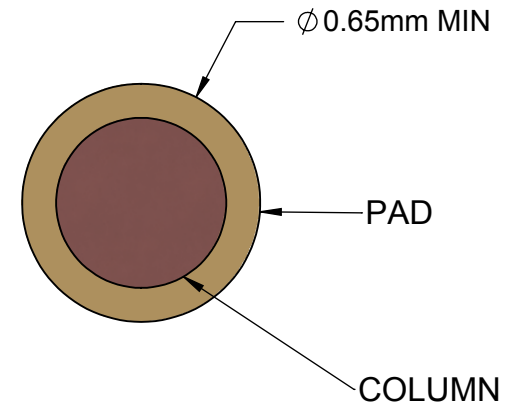

9B8`J`9K

- Notes: (Unless Otherwise Specified).  
 1) DIMENSIONS IN mm [INCHES].  
 2) MATERIAL: Cu ALLOY CDA101 Cu99.99 (4N)  
 3) PLATING: UNPLATED - NO SURFACE TREATMENT.  
 4) PACKAGING: JAR IN VACUUM SEAL BAG N2 (Nitrogen Flush)

APPROVALS	DATE	<b>TopLine®</b>			
DRAWN T. Au	9/19/2018				
ENG M. Hart	9/19/2018	TITLE CU101U18x50-N2 COPPER PILLAR			
MFG		SCALE	SIZE	DRAWING NO.	REV
QA		50:1	A	401850	A
CUST		DO NOT SCALE DRAWING			SHEET 1 OF 1
REVISED					