

# GLASS CHIPS WITHOUT METALLIZATION

## TOP VIEW

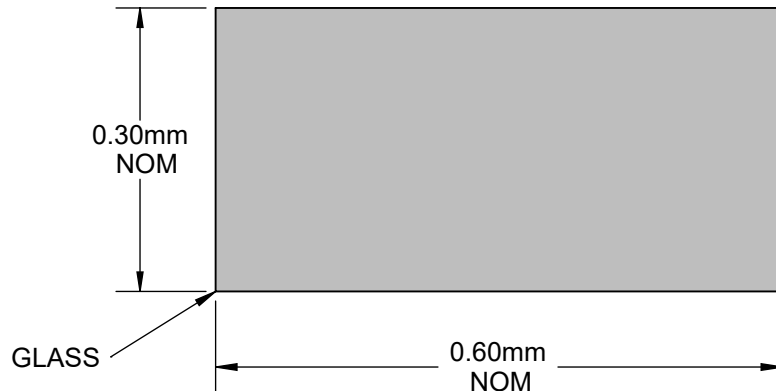

## SIDE VIEW

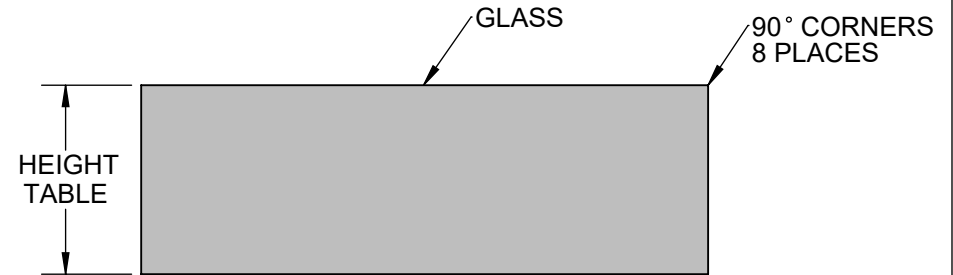

### NOTES:

1. DIMENSION: mm EXCEPT AS NOTED.
2. METALLIZATION: NONE.
3. Pb-FREE AND HALOGEN FREE.
4. COLORS: TRANSLUCENT.
5. CORNER CHIPOUT 50um TYP.
6. MATERIAL: BOROSILICATE GLASS.

PART NUMBER	HEIGHT +/-0.025mm (1.0 mil)		
	mm	um	mil
GCC020108-D-E7A	0.20mm	200um	7.9mil
GCC020109-D-E7A	0.23mm	230um	9.0mil
GCC020110-D-E7A	0.25mm	250um	9.8mil
GCC020111-D-E7A	0.28mm	280um	11.0mil
GCC020112-D-E7A	0.31mm	310um	12.2mil
GCC020113-D-E7A	0.33mm	330um	13.0mil
GCC020114-D-E7A	0.35mm	350um	13.8mil
GCC020115-D-E7A	0.38mm	380um	15.0mil
GCC020116-D-E7A	0.40mm	400um	15.8mil
GCC020117-D-E7A	0.43mm	430um	17.0mil
GCC020118-D-E7A	0.46mm	460um	18.0mil
GCC020119-D-E7A	0.48mm	480um	19.0mil
GCC020120-D-E7A	0.50mm	500um	19.7mil

### NOTES:

1. OTHER SIZES AND HEIGHTS AVAILABLE.
2. CARRIER TAPE CODE SUBJECT TO CHANGE from E7A to P7A.
3. SURFACE ROUGHNESS 2000Å RA (TOP/BOTTOM)

## MODEL

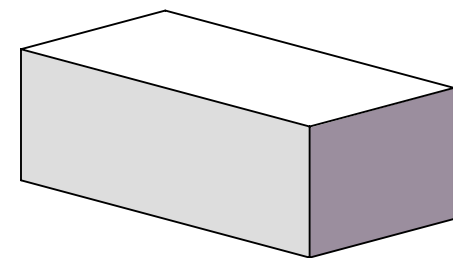

APPROVALS	DATE	<b>TopLine®</b>			
DRAWN T. Au	12/12/2023	TITLE GCC0201 PRECISION HEIGHT NON-METALLIZED CHIPS			
ENG M. Hart	12/12/2023				
MFG		SCALE	SIZE	DRAWING NO.	REV
QA		125:1	A	020105	B
CUST		DO NOT SCALE DRAWING			SHEET 1 OF 4
REVISED					

# PART NUMBERING SYSTEM

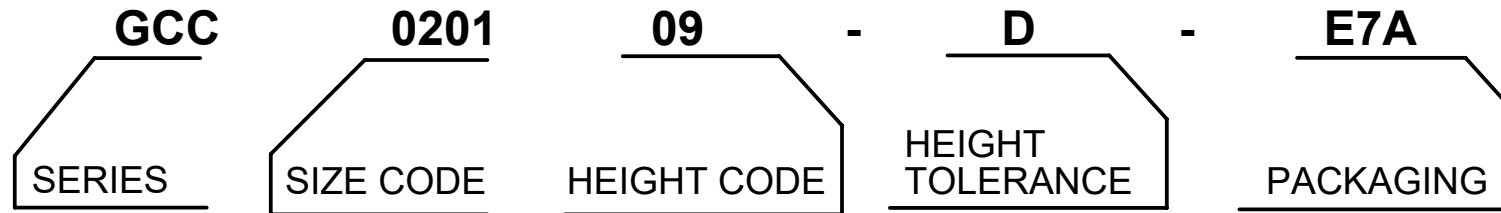

GCC =  
BOROSCILICATE  
GLASS CHIP  
NON-METALLIZED

0201 =  
0.6x 0.3mm  
NOMINAL  
±0.05mm

08 = 0.20mm  
09 = 0.23mm  
10 = 0.25mm  
11 = 0.28mm  
12 = 0.31mm  
13 = 0.33mm  
14 = 0.35mm  
15 = 0.38mm  
16 = 0.40mm  
17 = 0.43mm  
18 = 0.46mm  
19 = 0.48mm  
20 = 0.50mm  
Other Available

D = ± 0.025mm  
± 1.0mil

C = ±0.013mm  
±0.50mil

BLANK = HEIGHT  
TOLERANCE  
NOT STATED

E7A = PLASTIC  
CARRIER TAPE  
AND REEL

P7A = PAPER  
CARRIER TAPE  
AND REEL

B = BULK

E = CUT TAPE  
WITHOUT REEL

W = 2" WAFFLE  
PACK

**TopLine®**

TITLE GCC0201 PRECISION HEIGHT  
NON-METALLIZED CHIPS

SCALE NONE	SIZE A	DRAWING NO. 020105	REV B
---------------	-----------	-----------------------	----------

DO NOT SCALE DRAWING

SHEET 2 OF 4

# W8P2 CARRIER TAPE DIMENSION

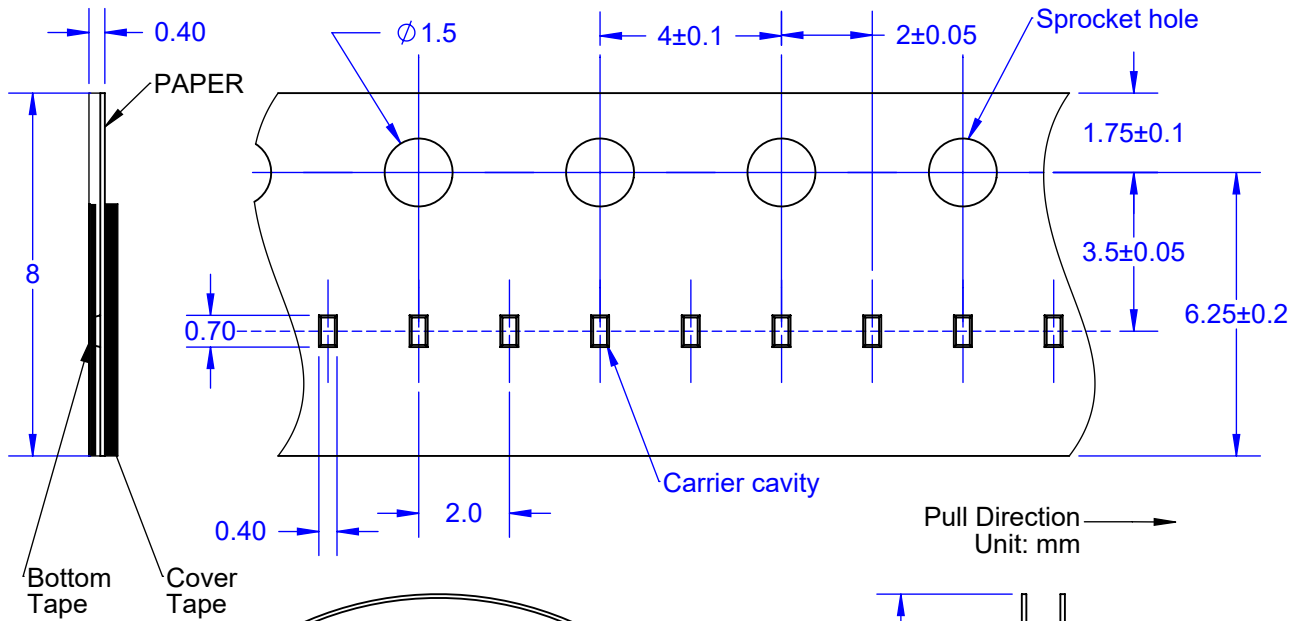

PACK CODE			
CODE	0201	PACKAGE	TAPE
P7A	3,000	REEL	PAPER
P4A	1,000	REEL	PAPER

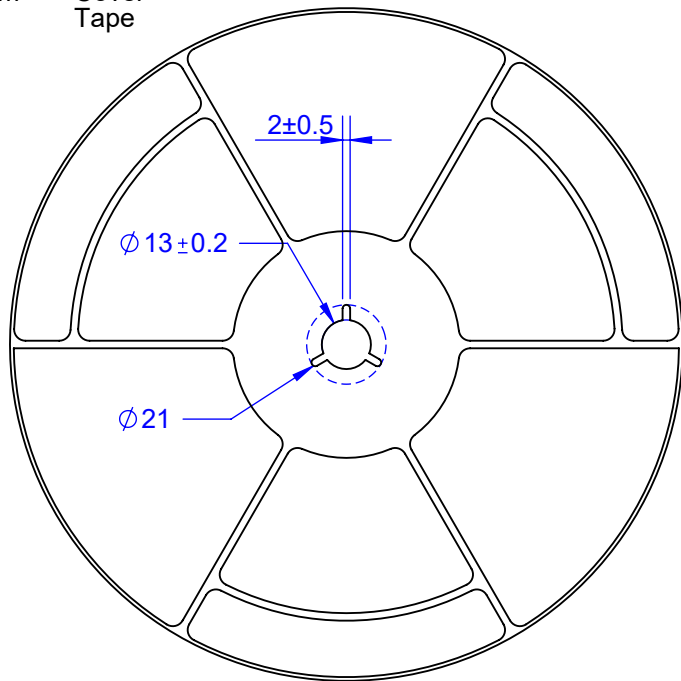

## REEL DIMENSIONS

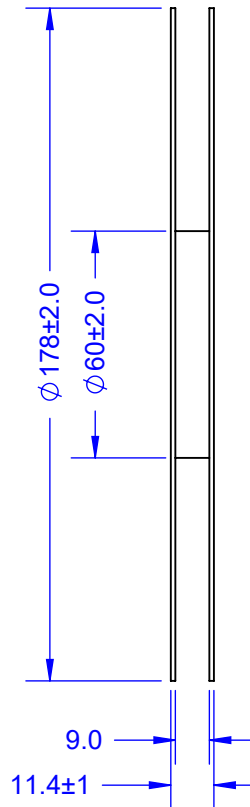

**PRELIMINARY**

			
TITLE GCC0201 PRECISION HEIGHT NON-METALLIZED CHIPS			
SCALE NONE	SIZE A	DRAWING NO. 020105	REV B
DO NOT SCALE DRAWING			SHEET 3 OF 4

REVISED

# W8P4 CARRIER TAPE DIMENSION

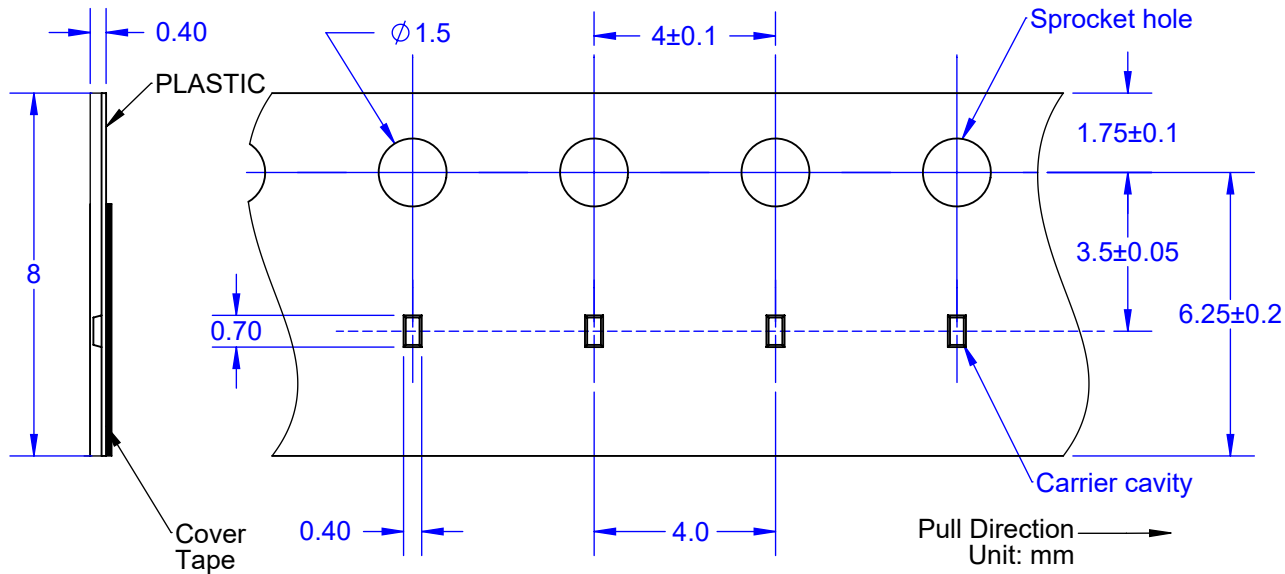

PACK CODE			
CODE	0201	PACKAGE	TAPE
E7A	3,000	REEL	PLASTIC
E4A	1,000	REEL	PLASTIC

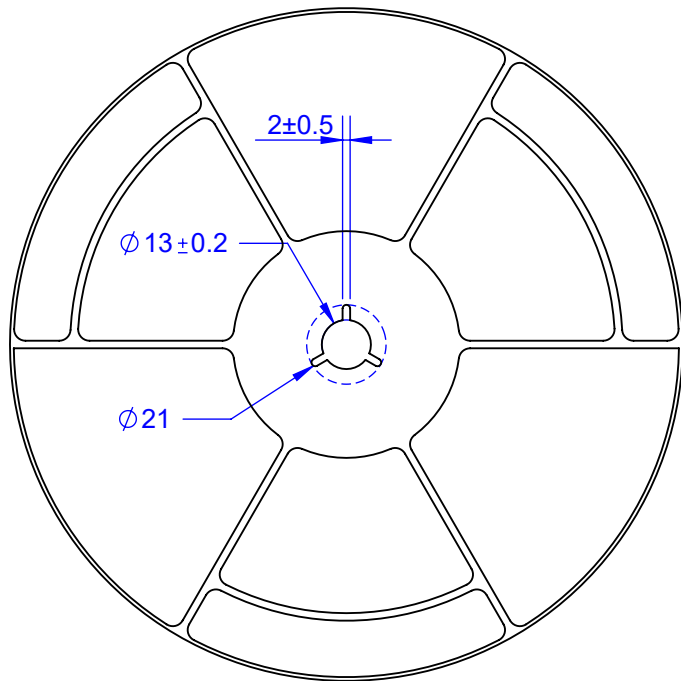

## REEL DIMENSIONS

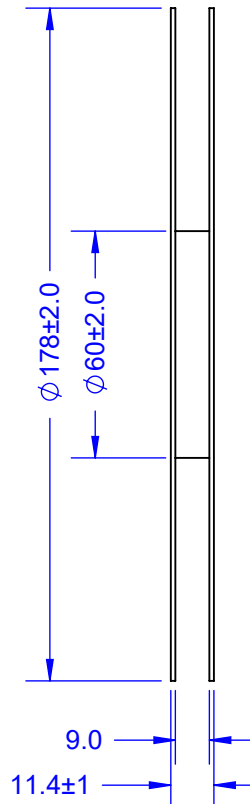

**PRELIMINARY**

<b>TopLine®</b>			
TITLE GCC0201 PRECISION HEIGHT NON-METALLIZED CHIPS			
SCALE NONE	SIZE A	DRAWING NO. 020105	REV B
DO NOT SCALE DRAWING			SHEET 4 OF 4

REVISED