

TOP VIEW

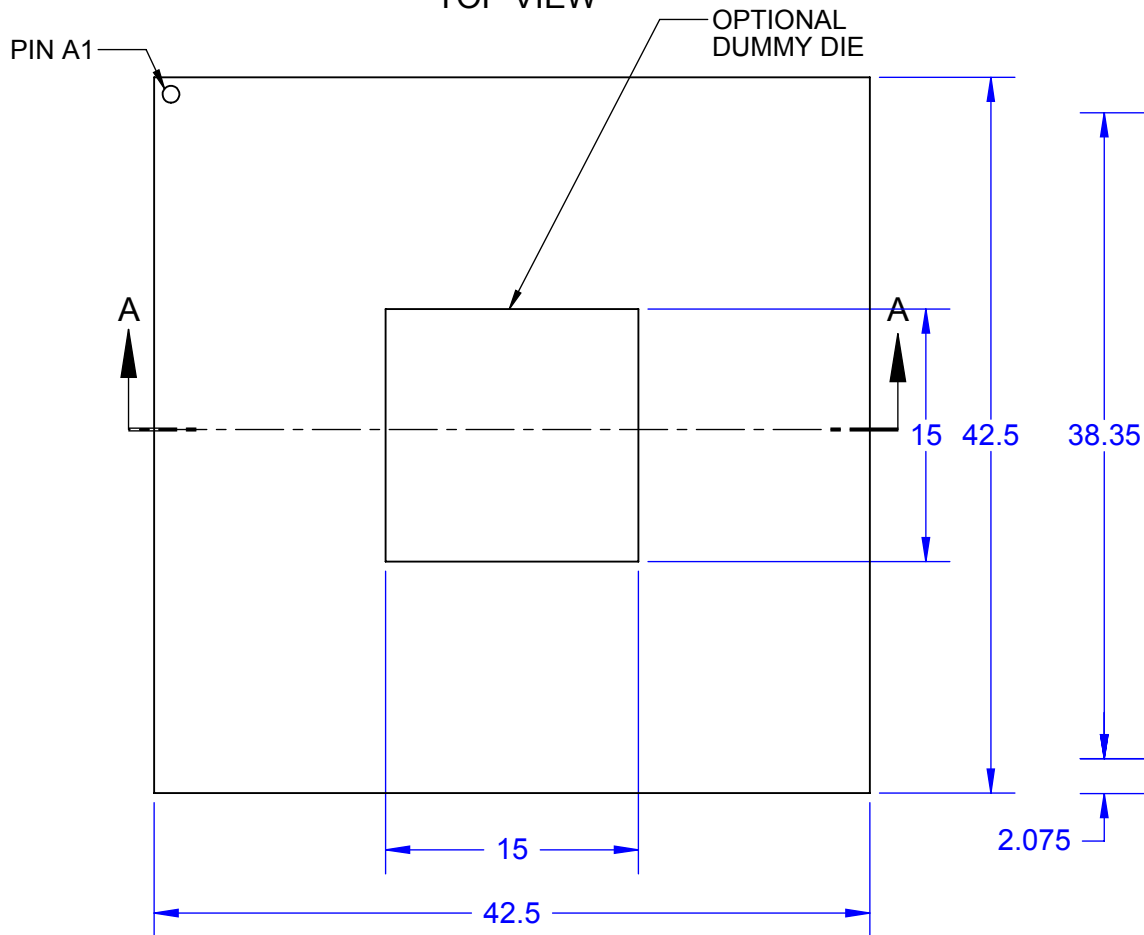

BALL VIEW

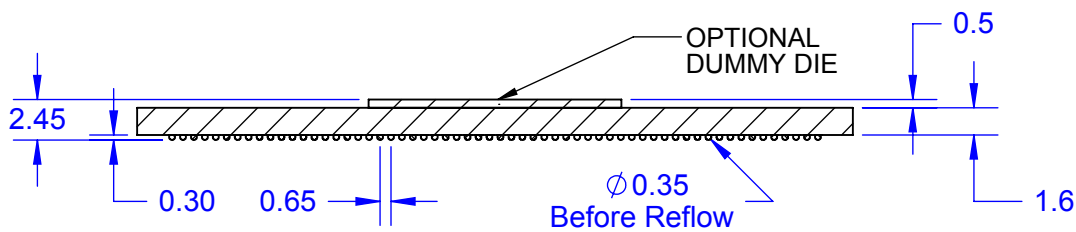
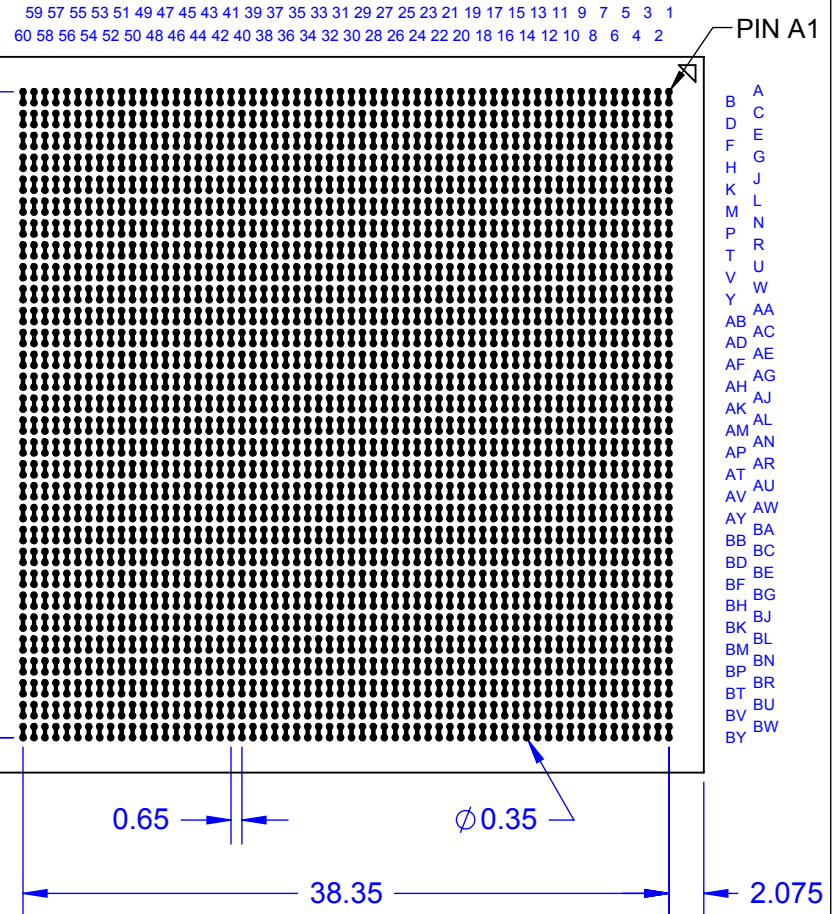

SECTION A-A

Notes: (Unless Otherwise Specified).

- 1) ALL DIMENSIONS ARE IN MM.
- 2) SOLDER BALL ALLOY: SEE PART NUMBER TABLE.
- 3) BALL DIAMETER (BEFORE REFLOW): 0.35mm (14 MIL).
- 4) SOLDER MASK DEFINED PAD OPENING: 0.33mm (13 MIL).
- 5) PAD Cu DIAMETER: 0.457mm (18 MIL).
- 6) SUBSTRATE MATERIAL: FR4 (ALTERNATE BT or Polyimide).
- 7) DUMMY DIE IS OPTIONAL.
- 8) DAISY CHAIN PATTERN (SEE PAGE 2).
- 9) MSL-3 RECOMMENDED BAKING 24 HOURS @ 125°C TO REMOVE MOISTURE PRIOR SOLDERING TO PC BOARD.

PART NUMBER TABLE

PART NUMBER	BALL ALLOY	Pb-Free	RoHS	Si DIE
LBGA3600T.65C-DC609	Sn96.5/Ag3.0/Cu0.5	YES	YES	NO
LBGA3600T.65C-DC609D	Sn96.5/Ag3.0/Cu0.5	YES	YES	YES
LBGA3600T.65-DC609	Sn63/Pb37	NO	NO	NO
LBGA3600T.65-DC609D	Sn63/Pb37	NO	NO	YES

APPROVALS	DATE				
DRAWN T.Au	11/1/2011	TITLE LBGA3600T.65-DC609 DAISY CHAIN DUMMY			
ENG M. Hart	11/1/2013				
MFG					
QA		SCALE 2.2:1	SIZE A	DRAWING NO. 566091	REV A
CUST		DO NOT SCALE DRAWING			SHEET 1 OF 3
REVISED					

## BALL VIEW

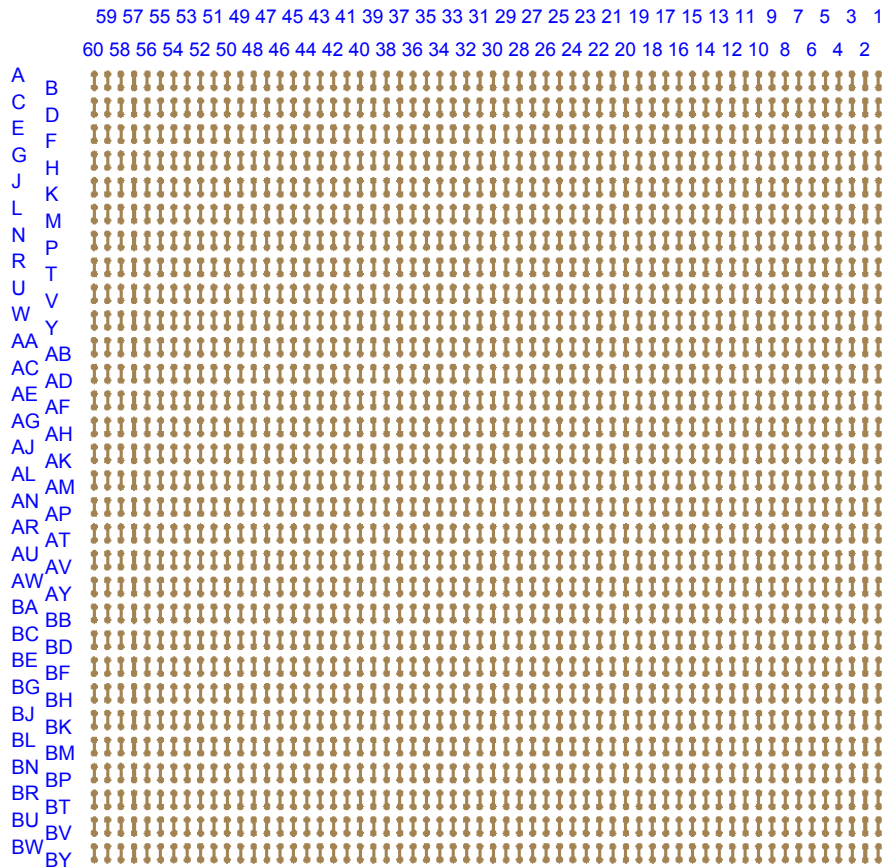

## BOTTOM SIDE (TOP X-RAY VIEW)



**Notes:**

- 1) PCB BOARD DIMENSIONS ARE PRESENTED ONLY AS A GUIDELINE. DESIGNERS SHOULD USE THEIR OWN EXPERIENCE WHEN DESIGNING PCB.
- 2) PCB Cu BALL PAD DIAMETER 0.457mm (18 MIL).
- 3) PCB DAISY CHAIN TRACING LINE WIDTH 0.152mm (6 MIL).
- 4) SMD (SOLDER MASK DEFINED) PAD OPENING: 0.33mm (13 MIL).

<b>TopLine®</b>			
TITLE		LBGA3600T.65-DC609 DAISY CHAIN DUMMY	
SCALE	SIZE	DRAWING NO.	REV
2.7:1	A	566091	A
DO NOT SCALE DRAWING			SHEET 2 OF 3

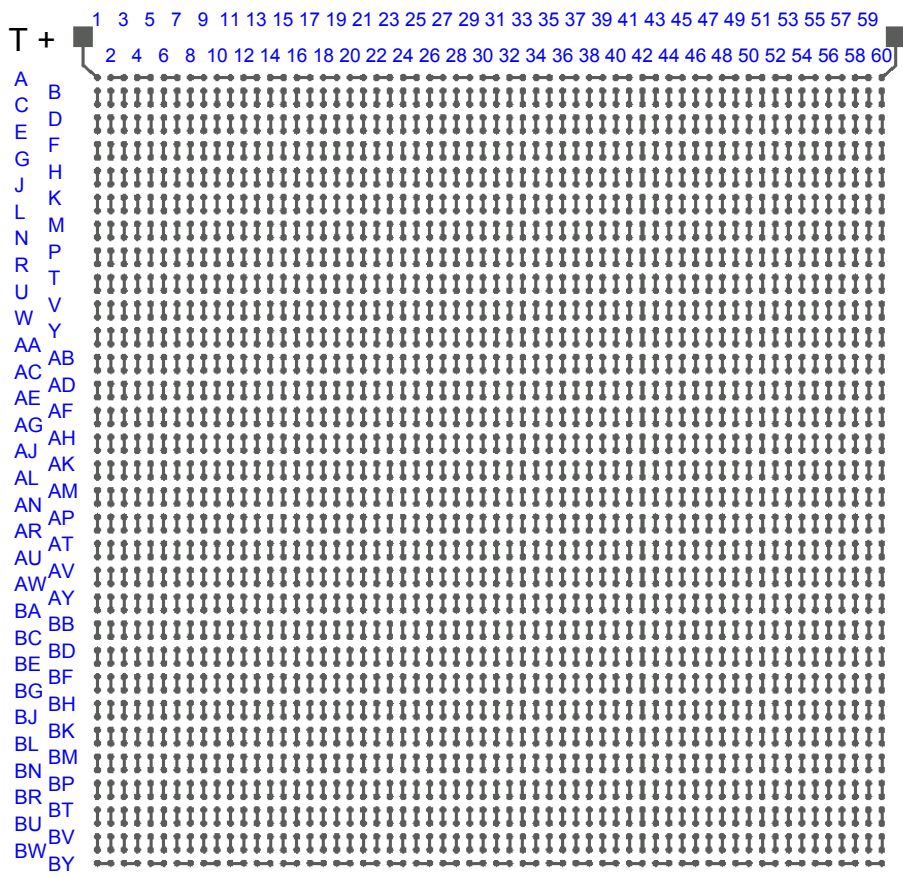

TEST VEHICLE BOARD

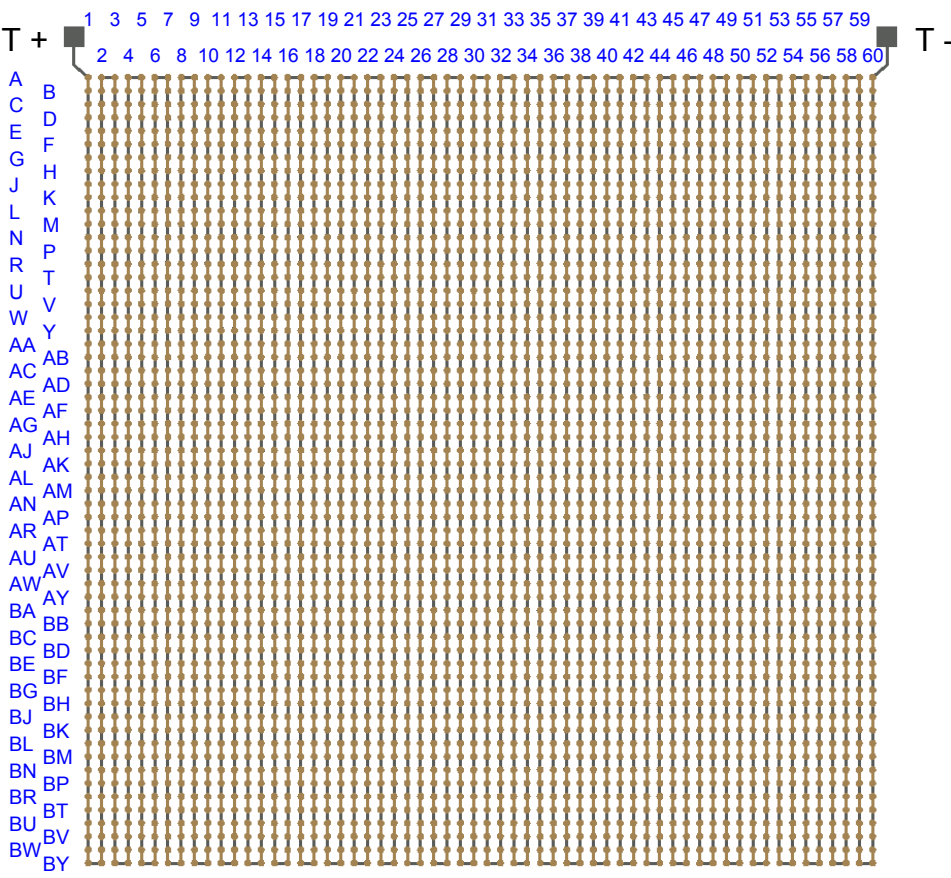

AFTER MOUNTING

- Notes:
- 1) PCB BOARD DIMENSIONS ARE PRESENTED ONLY AS A GUIDELINE. DESIGNERS SHOULD USE THEIR OWN EXPERIENCE WHEN DESIGNING PCB.
  - 2) PCB Cu BALL PAD DIAMETER 0.457mm (18 MIL).
  - 3) PCB DAISY CHAIN TRACING LINE WIDTH 0.152mm (6 MIL).
  - 4) SMD (SOLDER MASK DEFINED) PAD OPENING: 0.33mm (13 MIL).

<b>TopLine®</b>			
TITLE		LBGA3600T.65-DC609 DAISY CHAIN DUMMY	
SCALE	SIZE	DRAWING NO.	REV
2.7:1	A	566091	A
DO NOT SCALE DRAWING			SHEET 3 OF 3