

TOP VIEW

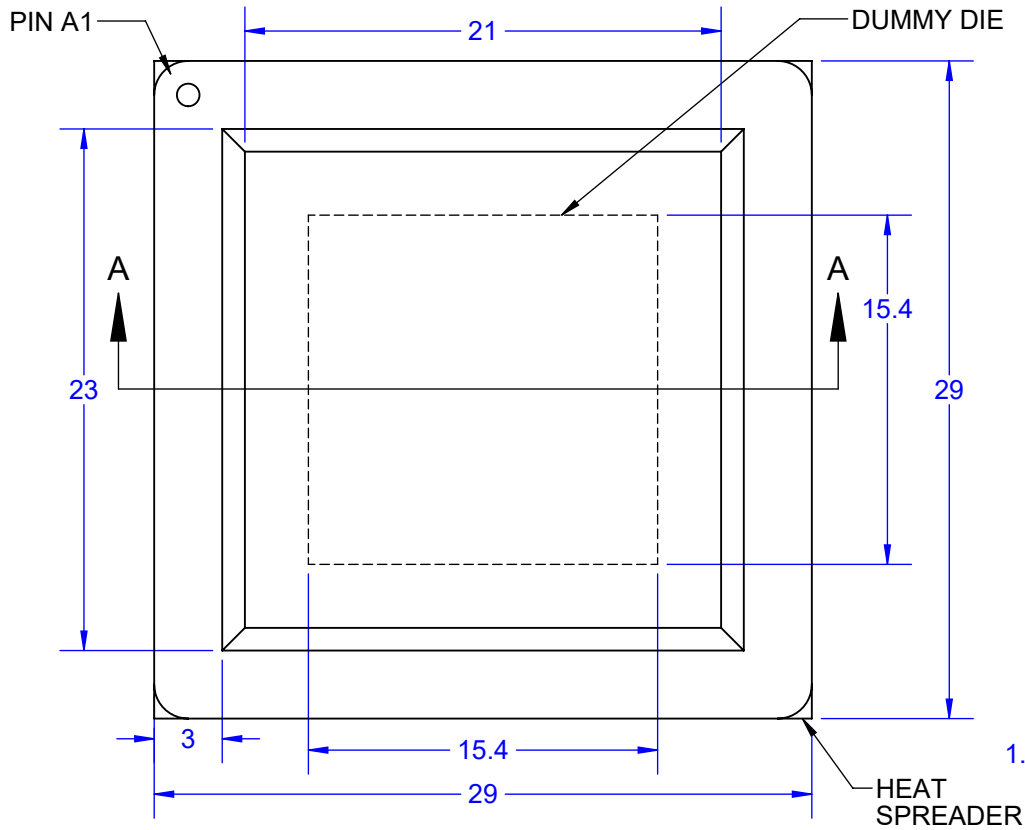

BALL VIEW

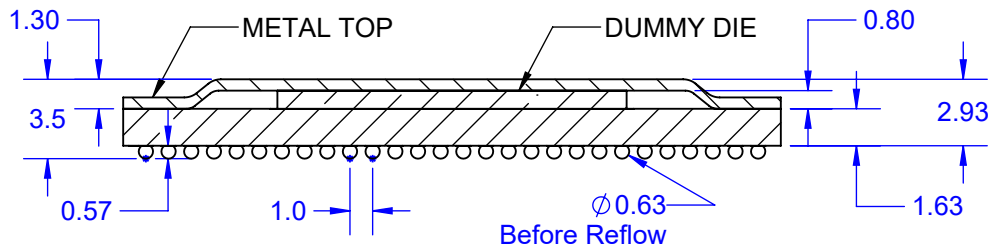
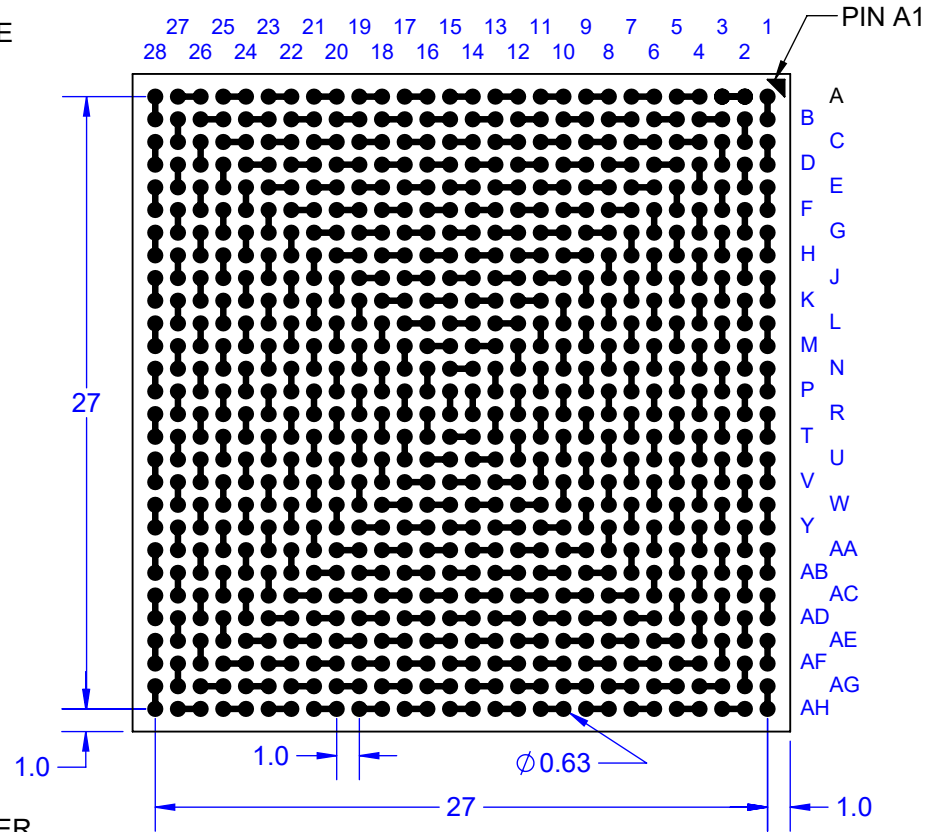

SECTION A-A

Notes: (Unless Otherwise Specified).

- 1) ALL DIMENSIONS ARE IN MM.
- 2) SOLDER BALL ALLOY: SEE PART NUMBER TABLE.
- 3) BALL DIAMETER (BEFORE REFLOW): 0.635mm (25 MIL).
- 4) SOLDER MASK DEFINED PAD OPENING: 0.508mm (20 MIL).
- 5) PAD Cu DIAMETER: 0.635mm (25 MIL).
- 6) SUBSTRATE MATERIAL: BT.
- 7) DAISY CHAIN PATTERN (SEE PAGE 2).
- 8) MSL-3 RECOMMENDED BAKING 24 HOURS @ 125°C TO REMOVE MOISTURE PRIOR SOLDERING TO PC BOARD.

PART NUMBER TABLE				
PART NUMBER	BALL ALLOY	BALL ALLOY	RoHS	Si DIE
SBGA783T1.0C-DC289D	Sn96.5/Ag3.0/Cu0.5	SAC305	YES	YES
SBGA783T1.0-DC289D	Sn63/Pb37	Sn63	NO	YES

APPROVALS	DATE	TopLine®		
DRAWN T. Au	7/13/2024			
ENG M. Hart	7/13/2024	TITLE SBGA784T1.0C-DC289D DAISY CHAIN DUMMY		
MFG		SCALE 3:1	SIZE A	DRAWING NO. 512895
QA				REV A
CUST				
REVISED		DO NOT SCALE DRAWING		SHEET 1 OF 9

BALL VIEW

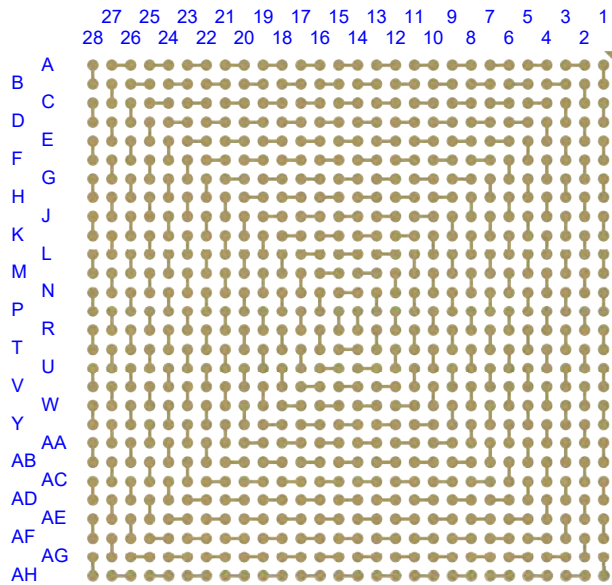

BOTTOM SIDE (TOP X-RAY VIEW)

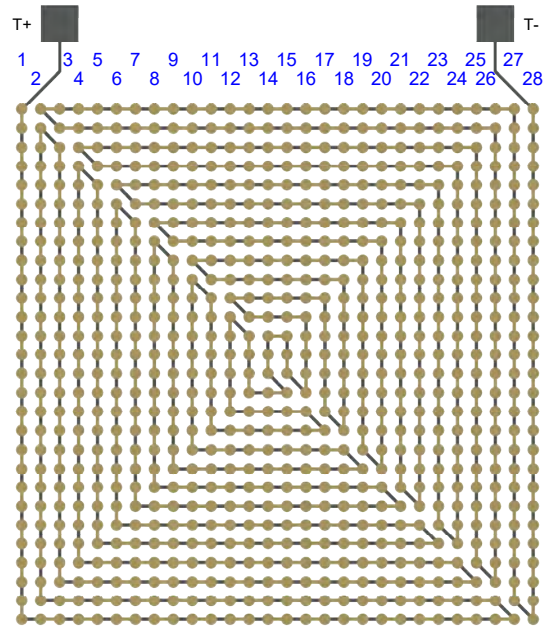
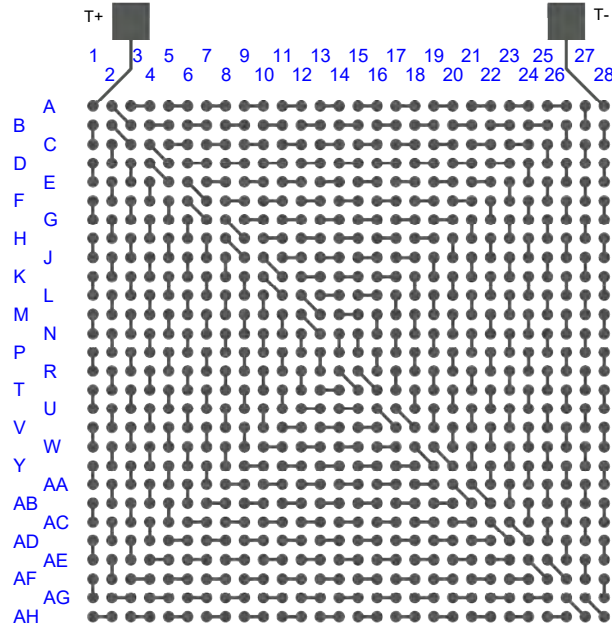
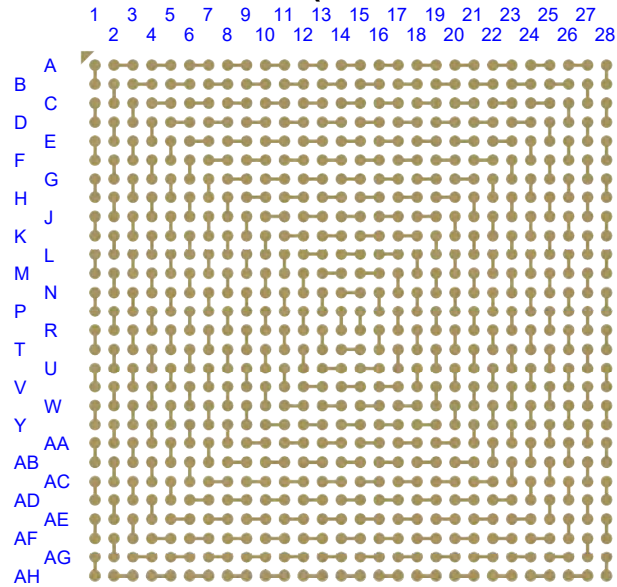

TEST VEHICLE BOARD

AFTER MOUNTING

Notes:

- 1) PCB BOARD DIMENSIONS ARE PRESENTD ONLY AS A GUIDELINE. DESIGNERS SHOULD USE THEIR OWN EXPERIENCE WHEN DESIGNING PCB.
- 2) PCB Cu BALL PAD DIAMETER 0.635mm [25 MIL].
- 3) PCB DAISY CHAIN TRACING LINE WIDTH 0.204mm [8 MIL].
- 4) SMD (SOLDER MASK DEFINED) PAD OPENING 0.508mm [20 MIL].



TITLE			
SBGA784T1.0C-DC289D DAISY CHAIN DUMMY			
SCALE	SIZE	DRAWING NO.	REV
2.5:1	A	512895	A
DO NOT SCALE DRAWING			SHEET 2 OF 9

BALL VIEW

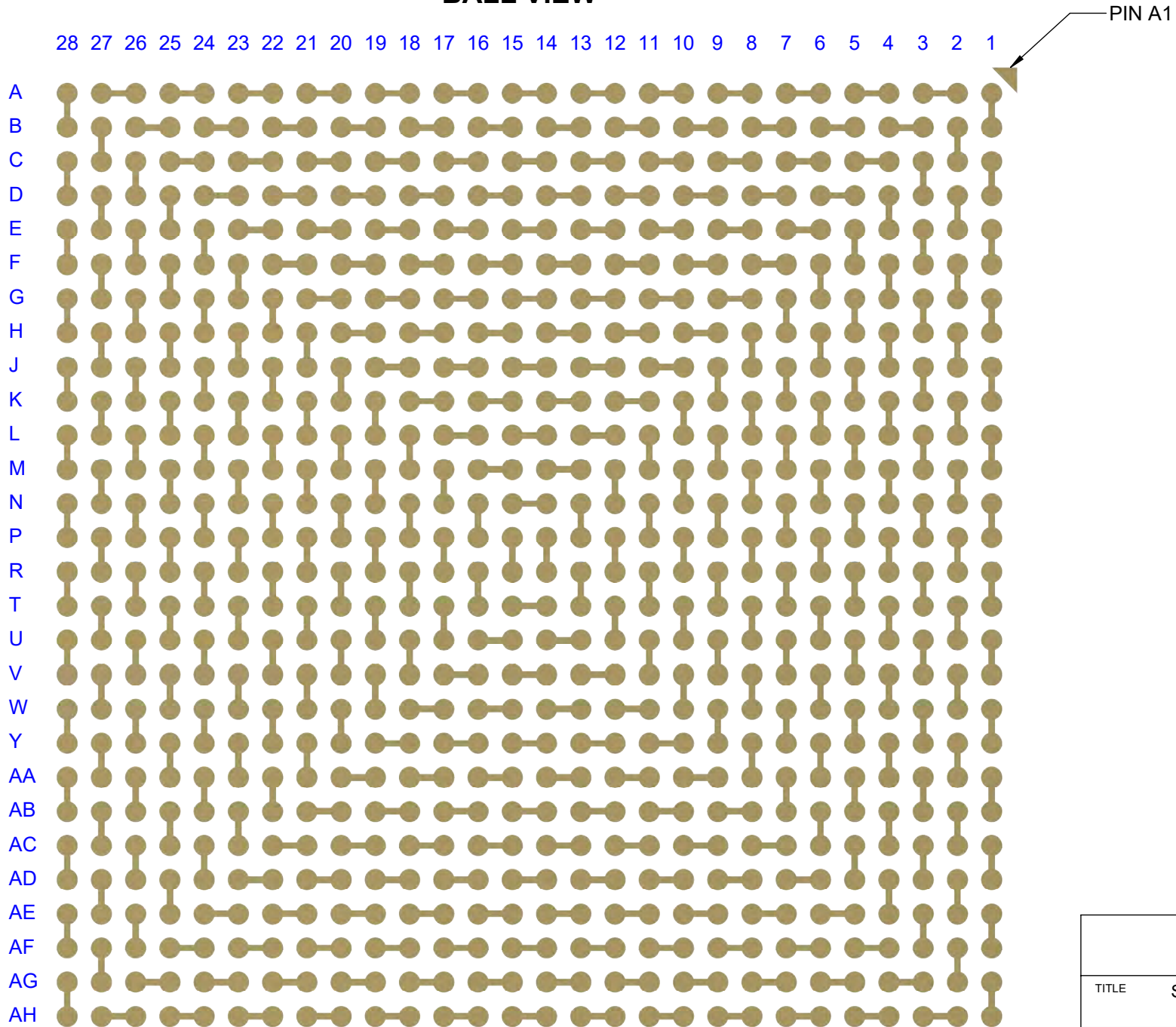

TopLine®			
TITLE SBGA784T1.0C-DC289D DAISY CHAIN DUMMY			
SCALE 6:1	SIZE A	DRAWING NO. 512895	REV A
DO NOT SCALE DRAWING		SHEET 3 OF 9	

BOTTOM SIDE (TOP X-RAY VIEW)

PIN A1

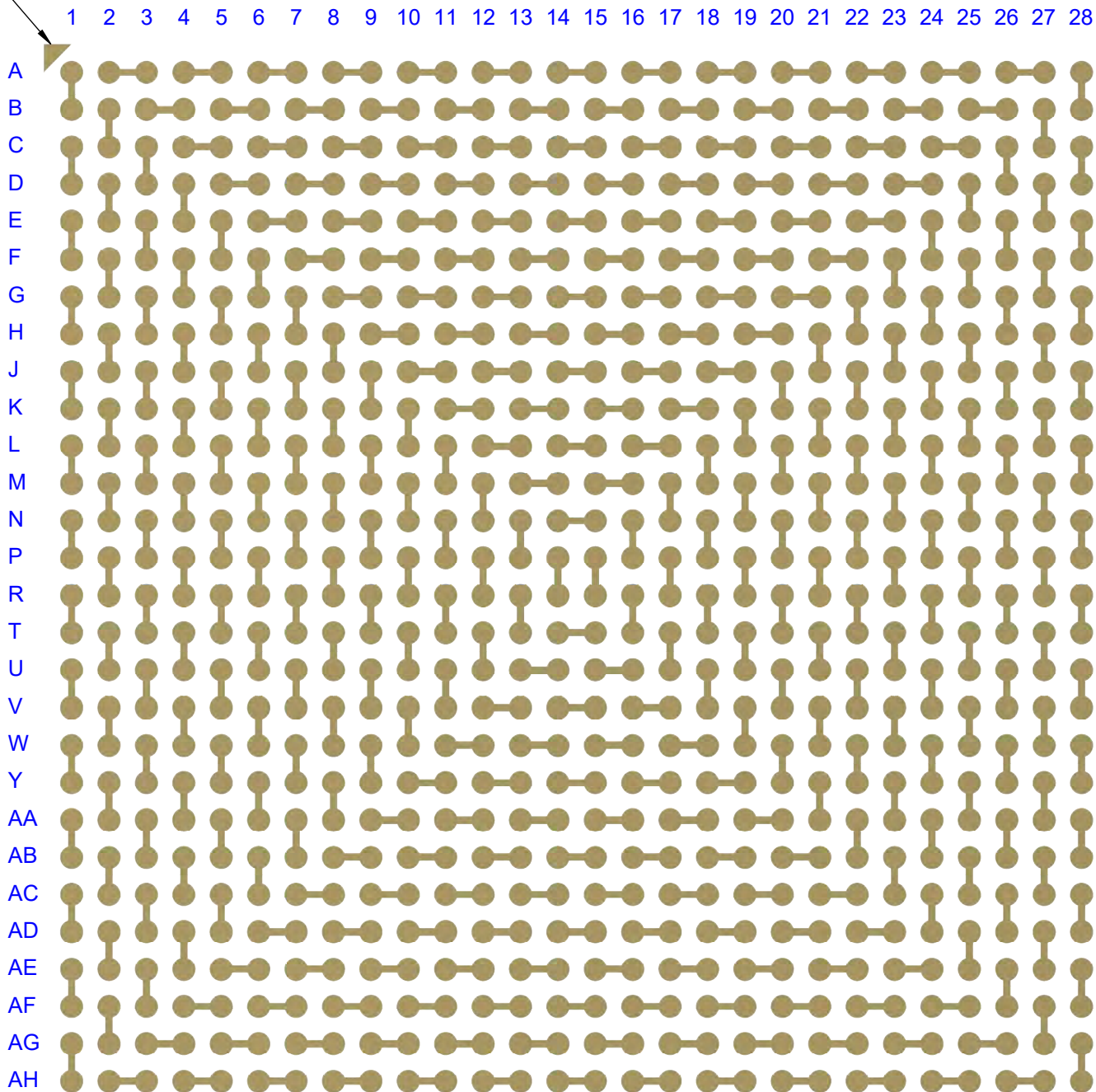

TopLine[®]			
TITLE SPGA784T1.0C-DC289D DAISY CHAIN DUMMY			
SCALE	SIZE	DRAWING NO.	REV
6:1	A	512895	A
DO NOT SCALE DRAWING			SHEET 4 OF 9

TEST VEHICLE BOARD

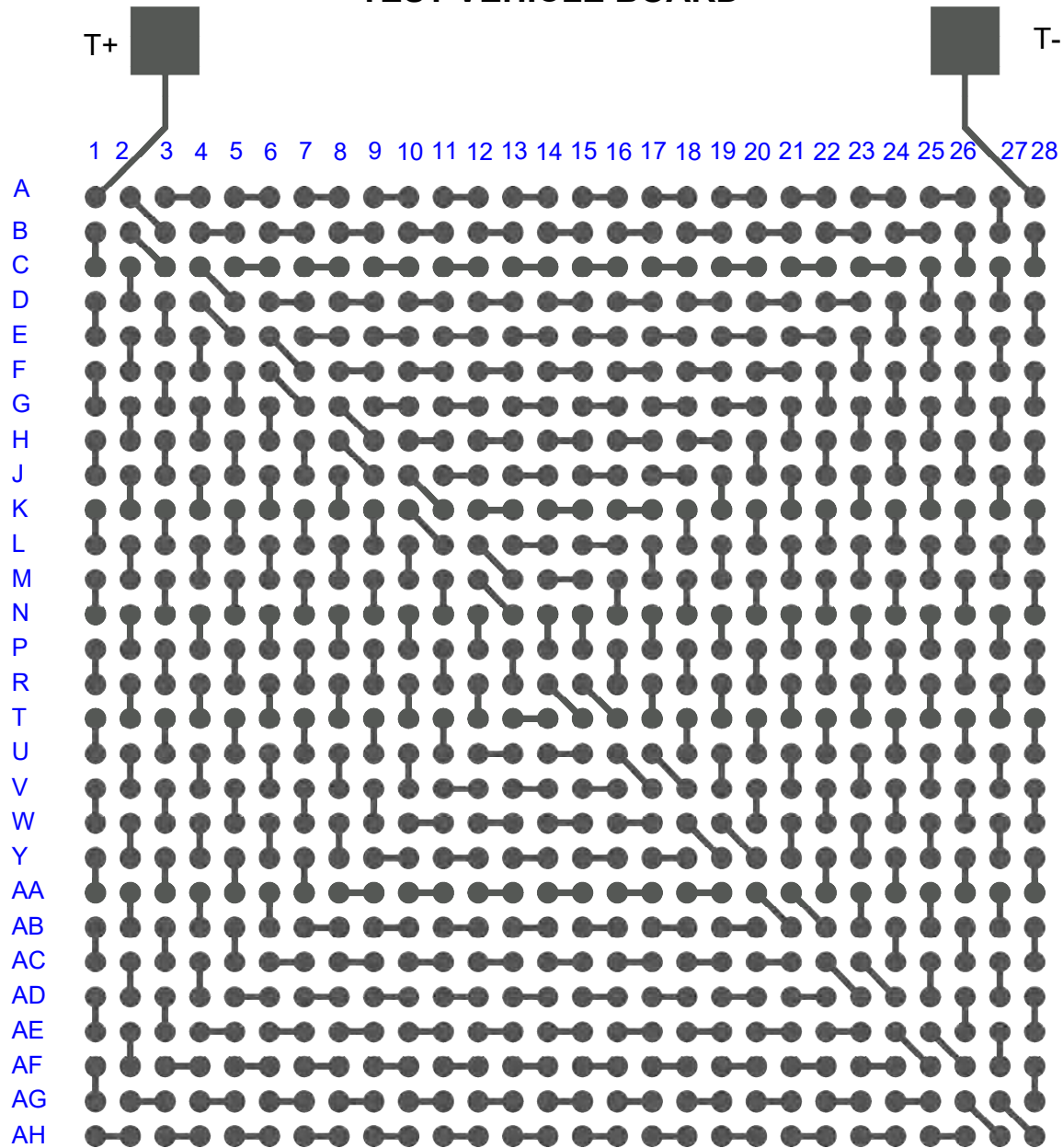

Notes:

- 1) PCB BOARD DIMENSIONS ARE PRESENTD ONLY AS A GUIDELINE. DESIGNERS SHOULD USE THEIR OWN EXPERIENCE WHEN DESIGNING PCB.
- 2) PCB Cu BALL PAD DIAMETER 0.635mm [25 MIL].
- 3) PCB DAISY CHAIN TRACING LINE WIDTH 0.204mm [8 MIL].
- 4) SMD (SOLDER MASK DEFINED) PAD OPENING 0.508mm [20 MIL].

TopLine[®]			
TITLE		SBGA784T1.0C-DC289D DAISY CHAIN DUMMY	
SCALE	SIZE	DRAWING NO.	REV
5:1	A	512895	A
DO NOT SCALE DRAWING			SHEET 5 OF 9

AFTER MOUNTING

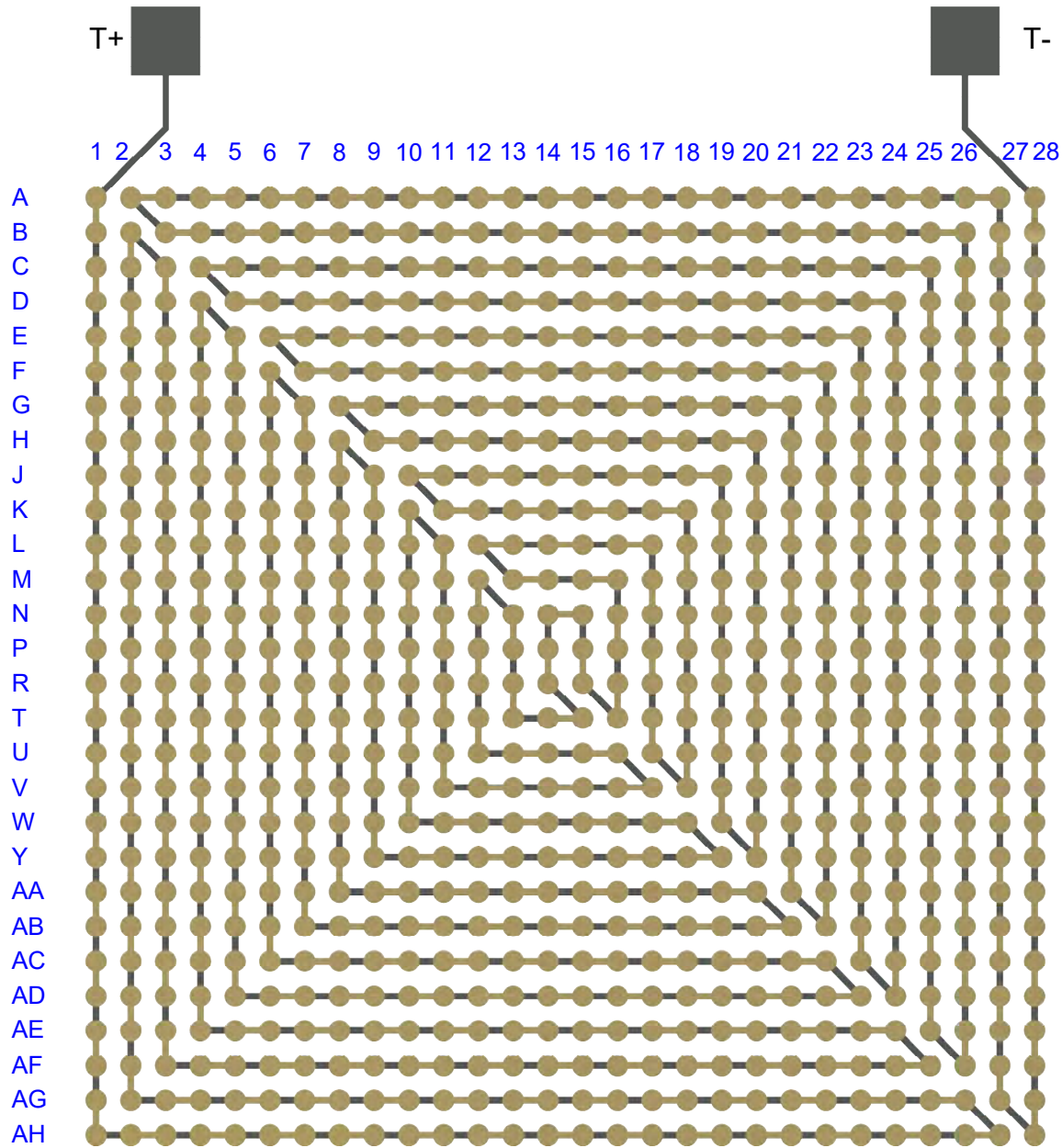

TopLine[®]

TITLE SBGA784T1.0C-DC289D
DAISY CHAIN DUMMY

SCALE 3.5:1	SIZE A	DRAWING NO. 512895	REV A
----------------	-----------	-----------------------	----------

DO NOT SCALE DRAWING

SHEET 6 OF 9

HEAT SPREADER

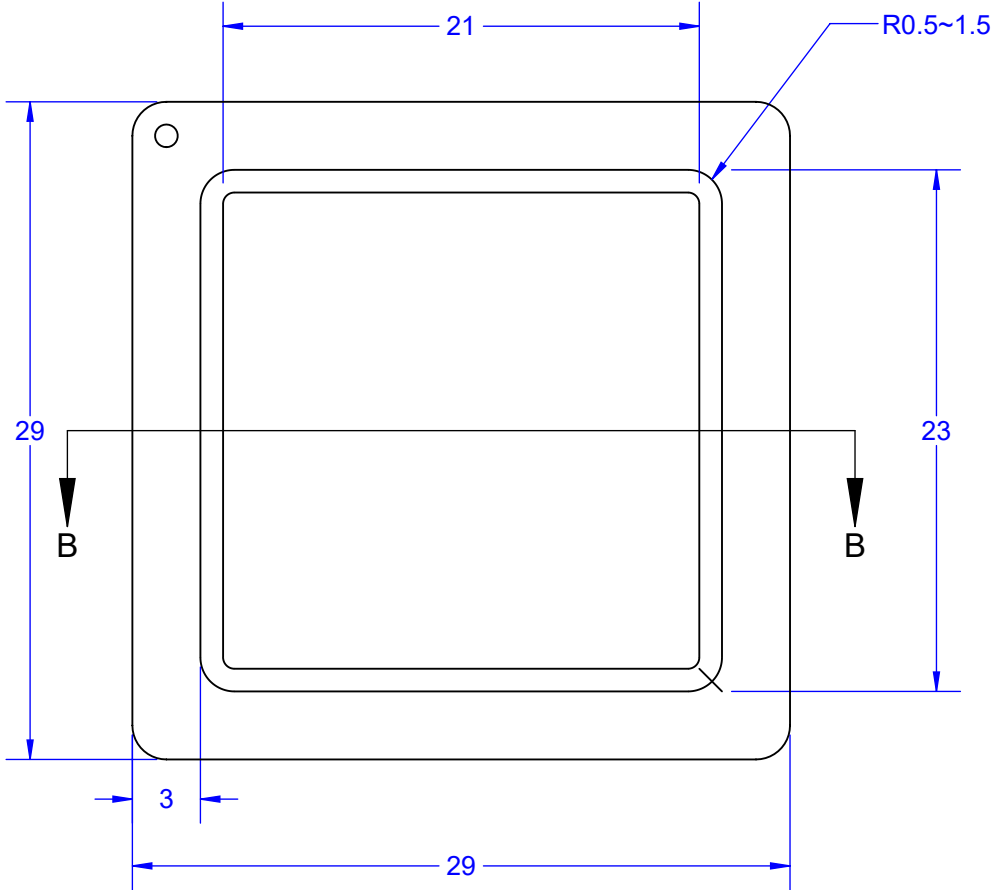

TOP

MODEL

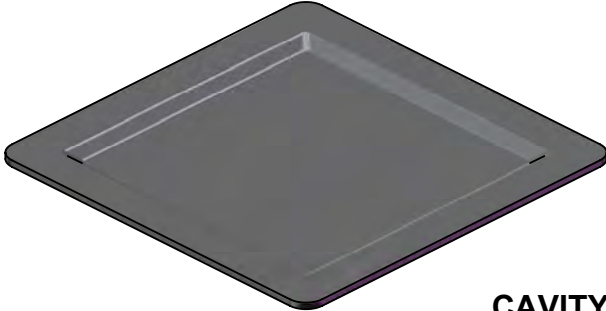

CAVITY

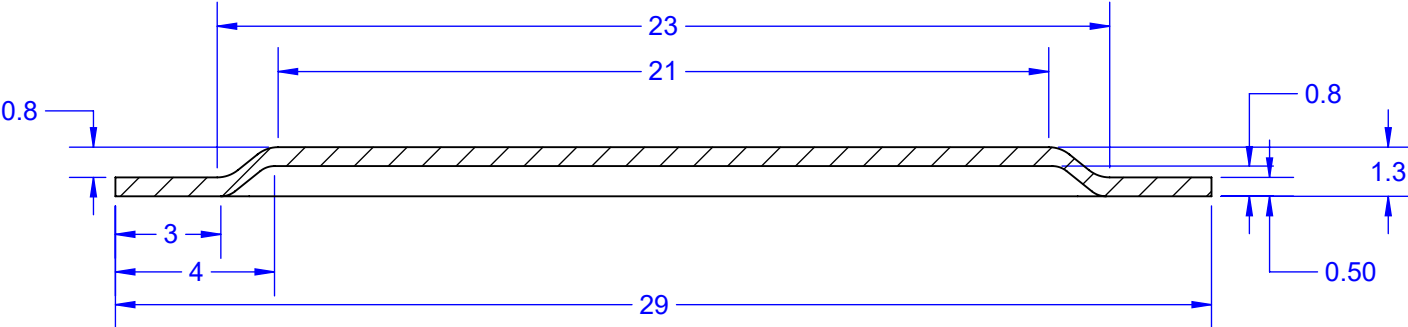

SECTION B-B
SCALE 3 : 1

TopLine®			
TITLE SBGA784T1.0C-DC289D DAISY CHAIN DUMMY			
SCALE 3:1	SIZE A	DRAWING NO. 512815	REV A
DO NOT SCALE DRAWING			SHEET 7 OF 9

MODEL

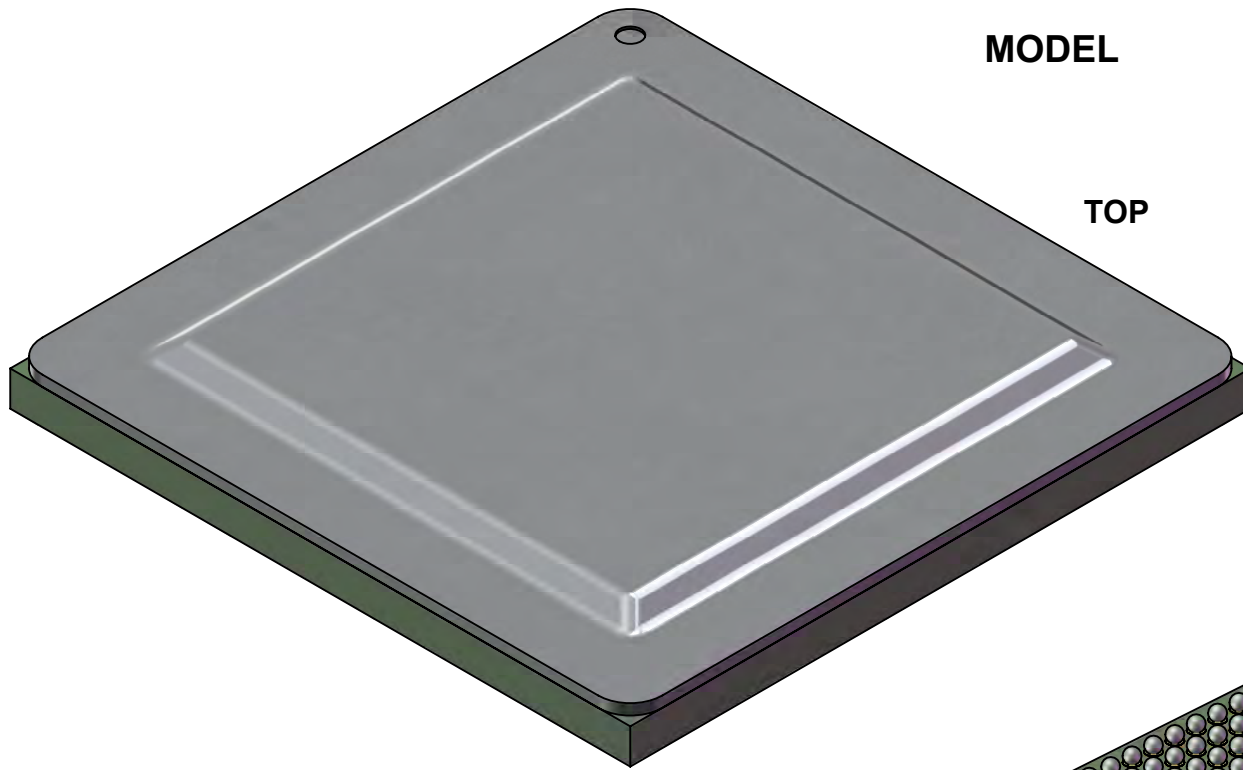

TOP

BALL VIEW

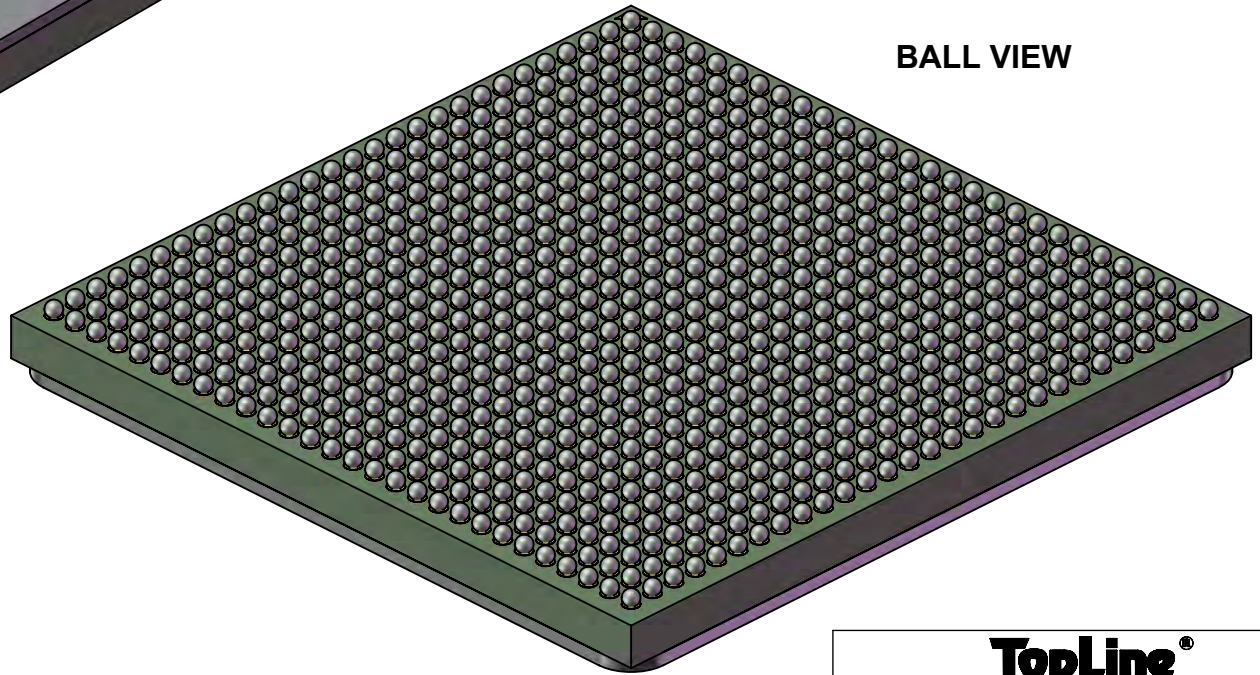

TopLine[®]

TITLE SBGA784T1.0C-DC289D
DAISY CHAIN DUMMY

SCALE 2:1	SIZE A	DRAWING NO. 512895	REV A
--------------	-----------	-----------------------	----------

DO NOT SCALE DRAWING

SHEET 8 OF 9

BOTTOM SOLDER MASK (RIGHT READING)

28 27 26 25 24 23 22 21 20 19 18 17 16 15 14 13 12 11 10 9 8 7 6 5 4 3 2 1

A
B
C
D
E
F
G
H
J
K
L
M
N
P
R
T
U
V
W
Y
AA
AB
AC
AD
AE
AF
AG
AH

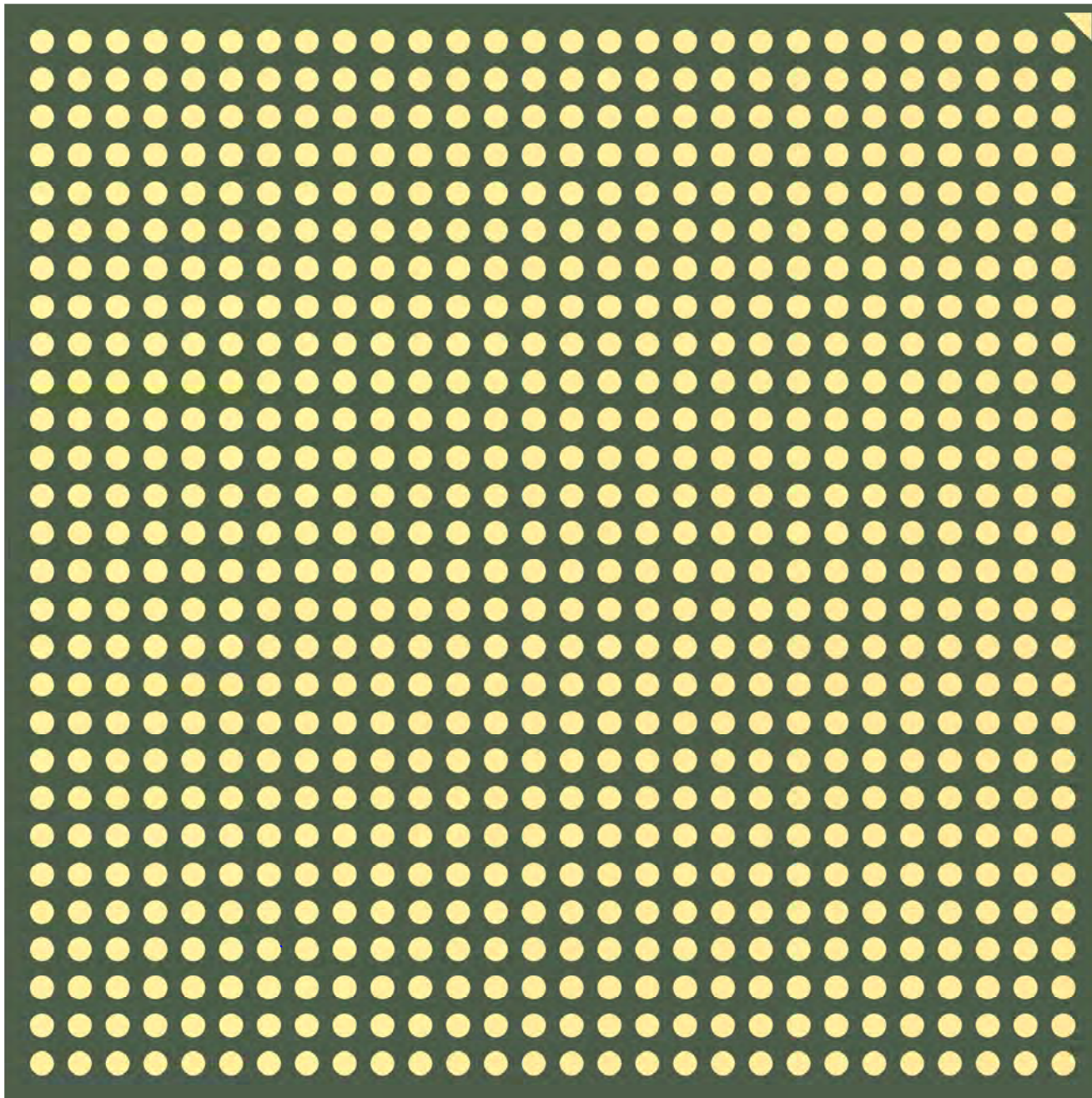

TopLine®			
TITLE SBGA784T1.0C-DC289D DAISY CHAIN DUMMY			
SCALE 6:1	SIZE A	DRAWING NO. 512895	REV A
DO NOT SCALE DRAWING			SHEET 9 OF 9