

### TOP VIEW

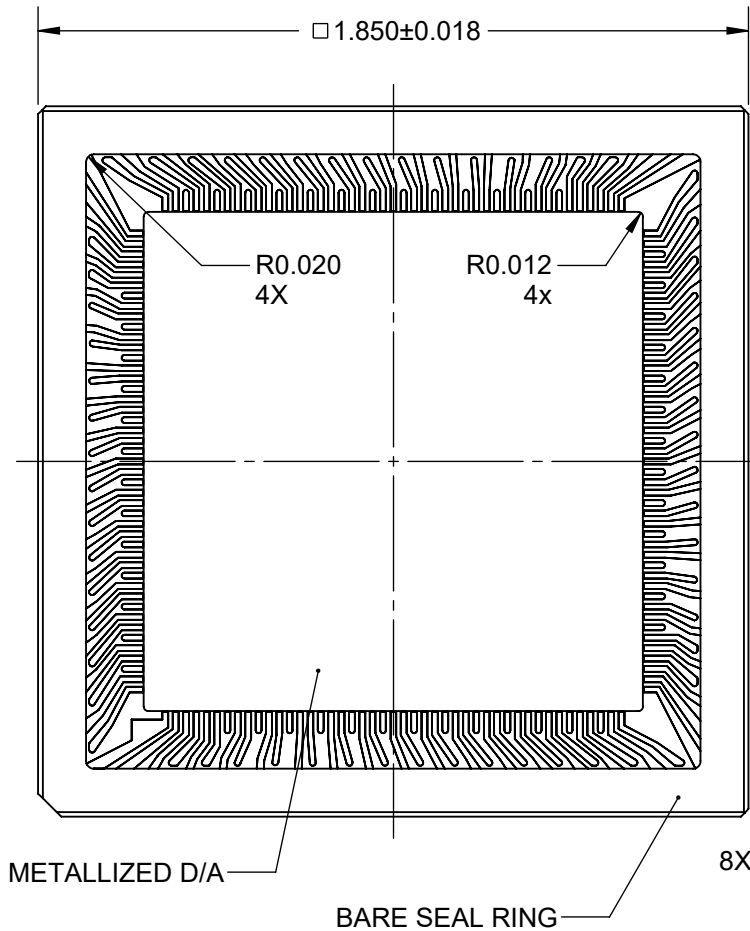

### SIDE VIEW

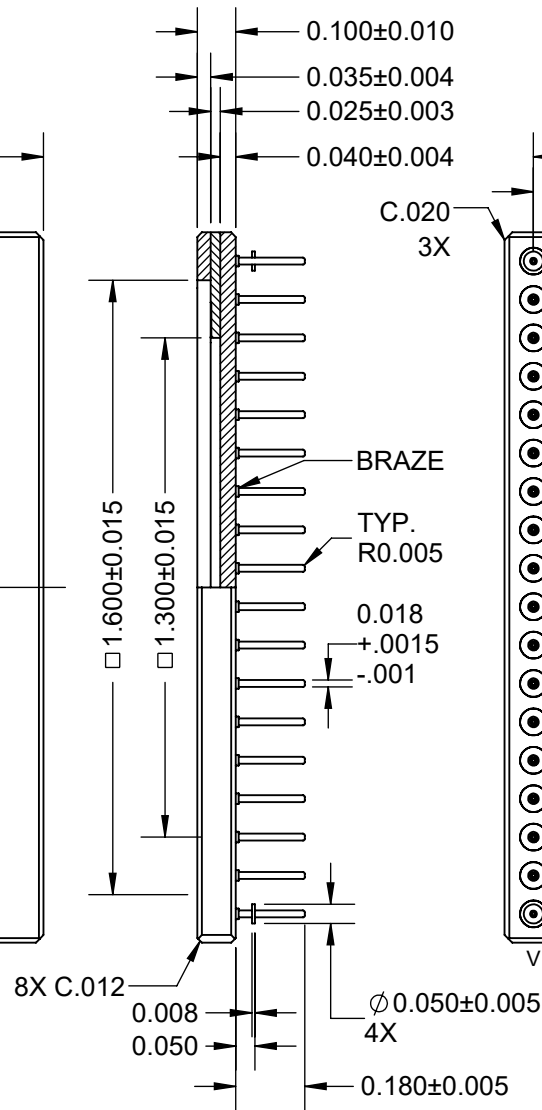

### BOTTOM VIEW

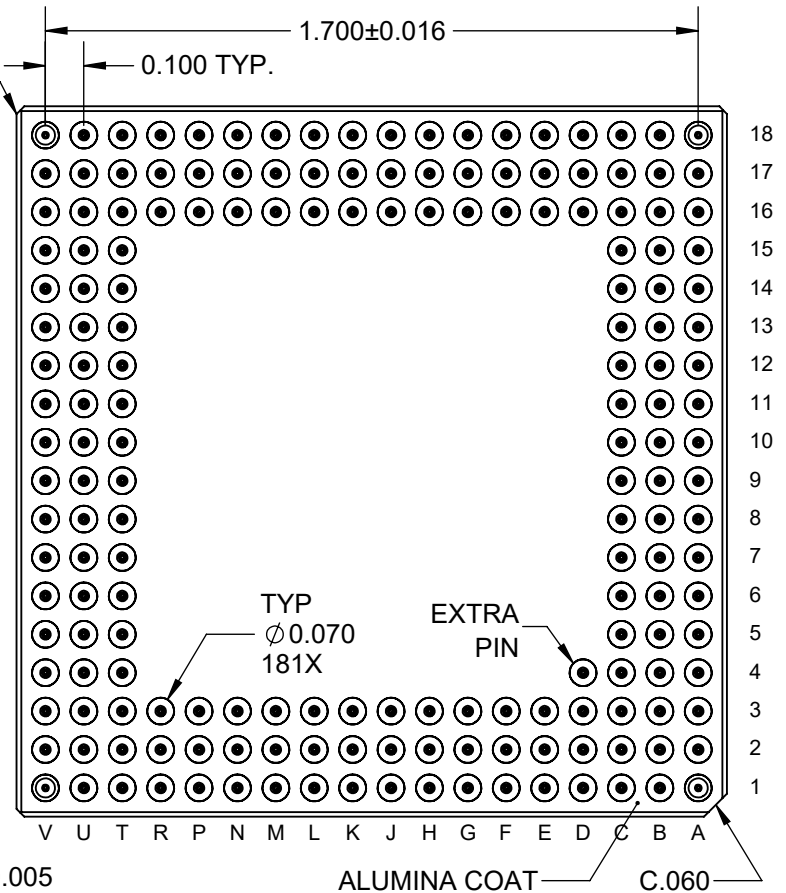

Notes: (Unless Otherwise Specified).

- 1) DIMENSIONS IN inches.
- 2) ALL EXPOSED METAL AND METALLIZED AREA SHALL BE GOLD PLATED 60 MICRO INCH MIN. THK. OVER NICKEL PLATED. 50~350 MICRO-INCH.
- 3) DIE ATTACH AREA SHALL BE METALLIZED AND CONNECTED TO PIN A1.
- 4) EXTRA PIN (D4) ISOLATED.
- 5) LEAD RESISTANCE: 500 Milli OHM MAXIMUM.
- 6) SEAL RING IS BARE WITHOUT METAL.

APPROVALS		DATE				
DRAWN	T. Au	12/30/2019				
ENG	M. Hart	12/30/2019	TITLE CPGA181T18x18-N1300 CERAMIC PIN GRID ARRAY			
MFG			SCALE	SIZE	DRAWING NO.	REV
QA			2:1	A	183534	A
CUST			DO NOT SCALE DRAWING			SHEET 1 OF 5
REVISED						

# BOND PAD

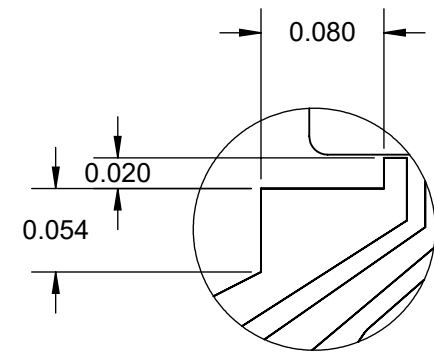
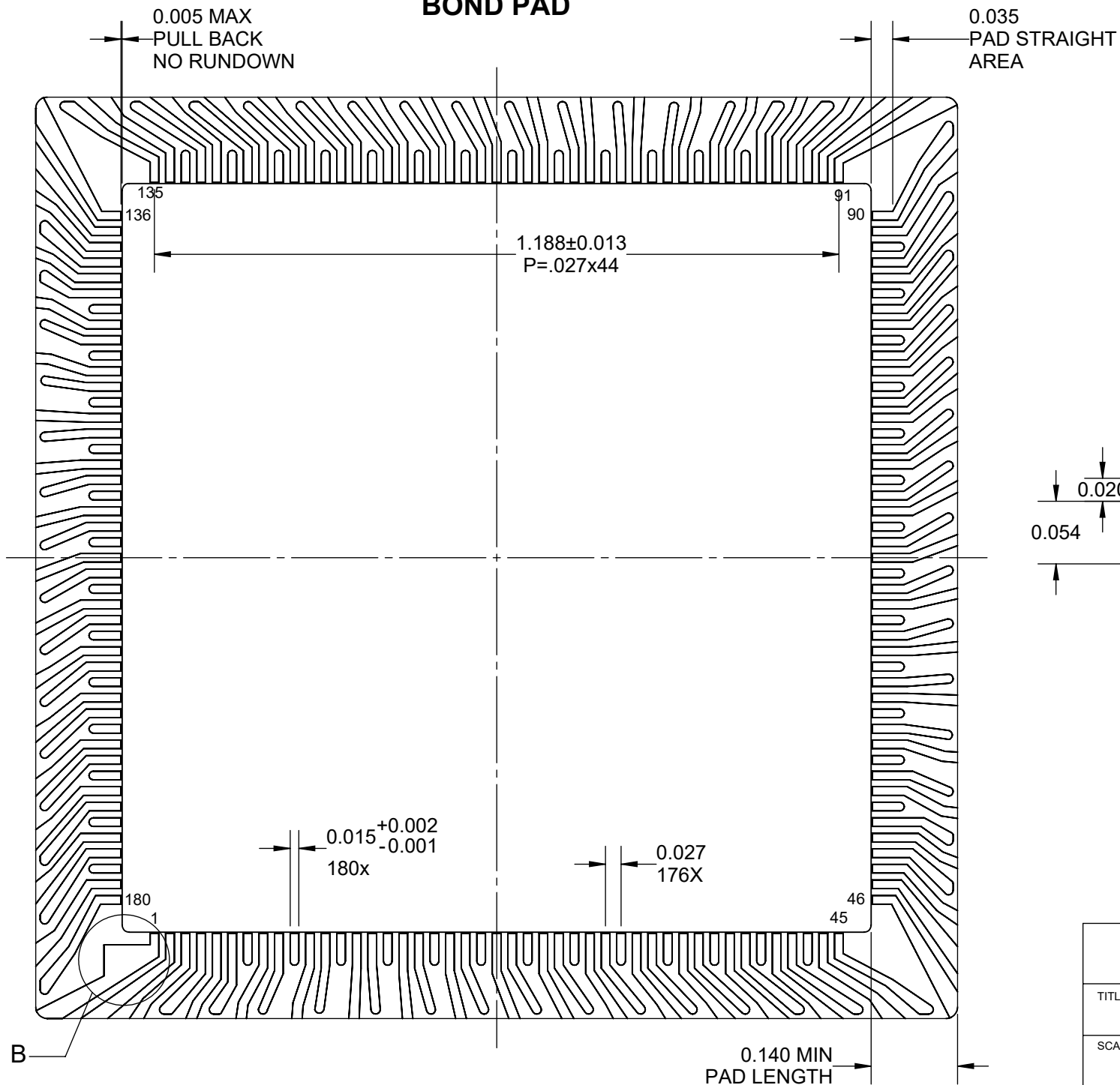

DETAIL B  
SCALE 8 : 1  
NO.1 INDEX MARK

**TopLine®**

TITLE CPGA181T18x18-N1300  
CERAMIC PIN GRID ARRAY

SCALE 4:1	SIZE A	DRAWING NO. 183534	REV A
--------------	-----------	-----------------------	----------

DO NOT SCALE DRAWING

SHEET 2 OF 5

## BOND PAD NET LIST

PAD	PIN
1	A1
2	B1
3	C1
4	C2
5	D1
6	D2
7	D3
8	E1
9	E2
10	E3
11	F1
12	F2
13	F3
14	G1
15	G2
16	G3
17	H1
18	H2
19	H3
20	J1
21	J2
22	J3
23	K1
24	K2
25	K3
26	L1
27	L2
28	L3
29	M1
30	M2

PAD	PIN
31	M3
32	N1
33	N2
34	N3
35	P1
36	P2
37	P3
38	R1
39	R2
40	R3
41	S1
42	S2
43	S3
44	T1
45	T2
46	U1
47	U2
48	U3
49	T3
50	U4
51	T4
52	S4
53	U5
54	T5
55	S5
56	U6
57	T6
58	S6
59	U7
60	T7

PAD	PIN
61	S7
62	U8
63	T8
64	S8
65	U9
66	T9
67	S9
68	U10
69	T10
70	S10
71	U11
72	T11
73	S11
74	U12
75	T12
76	S12
77	U13
78	T1
79	S13
80	U14
81	T14
82	S14
83	U15
84	T15
85	S15
86	U16
87	T16
88	S16
89	U17
90	T17

PAD	PIN
91	U18
92	T18
93	S18
94	S17
95	R18
96	R17
97	R16
98	P18
99	P17
100	P16
101	N18
102	N17
103	N16
104	M18
105	M17
106	M16
107	L18
108	L17
109	L16
110	K18
111	K17
112	K16
113	J18
114	J17
115	J16
116	H18
117	H17
118	H16
119	G18
120	G17

PAD	PIN
121	G16
122	F18
123	F17
124	F16
125	E18
126	E17
127	E16
128	D18
129	D17
130	D16
131	C18
132	C17
133	C16
134	B18
135	B17
136	A18
137	A17
138	A16
139	B16
140	A15
141	B15
142	C15
143	A14
144	B14
145	C14
146	A13
147	B13
148	C13
149	A12
150	B12

PAD	PIN
151	C12
152	A11
153	B11
154	C11
155	A10
156	B10
157	C10
158	A9
159	B9
160	C9
161	A8
162	B8
163	C8
164	A7
165	B7
166	C7
167	A6
168	B6
169	C6
170	A5
171	B5
172	C5
173	A4
174	B4
175	C4
176	A3
177	B3
178	C3
179	A2
180	B2

PAD	PIN
N/C	D4

			
TITLE CPGA181T18x18-N1300 CERAMIC PIN GRID ARRAY			
SCALE NONE	SIZE A	DRAWING NO. 183534	REV A
DO NOT SCALE DRAWING		SHEET 3 OF 5	

# SECTION / STACK UP VIEW

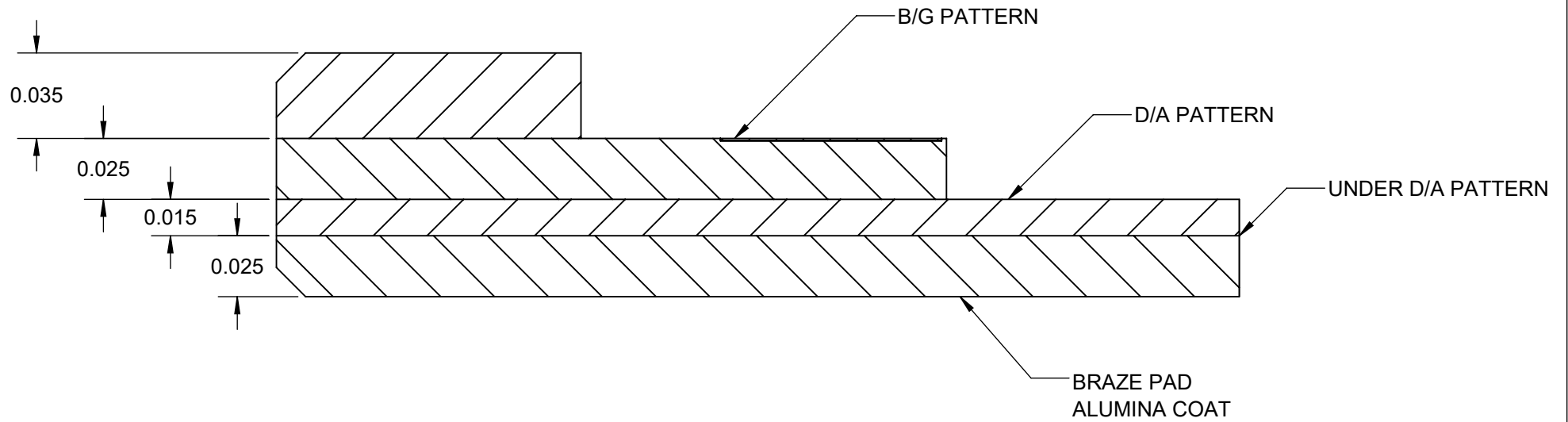

**TopLine®**

TITLE CPGA181T18x18-N1300  
CERAMIC PIN GRID ARRAY

SCALE 16:1	SIZE A	DRAWING NO. 183534	REV A
---------------	-----------	-----------------------	----------

DO NOT SCALE DRAWING

SHEET 4 OF 5

# MODEL

TOP

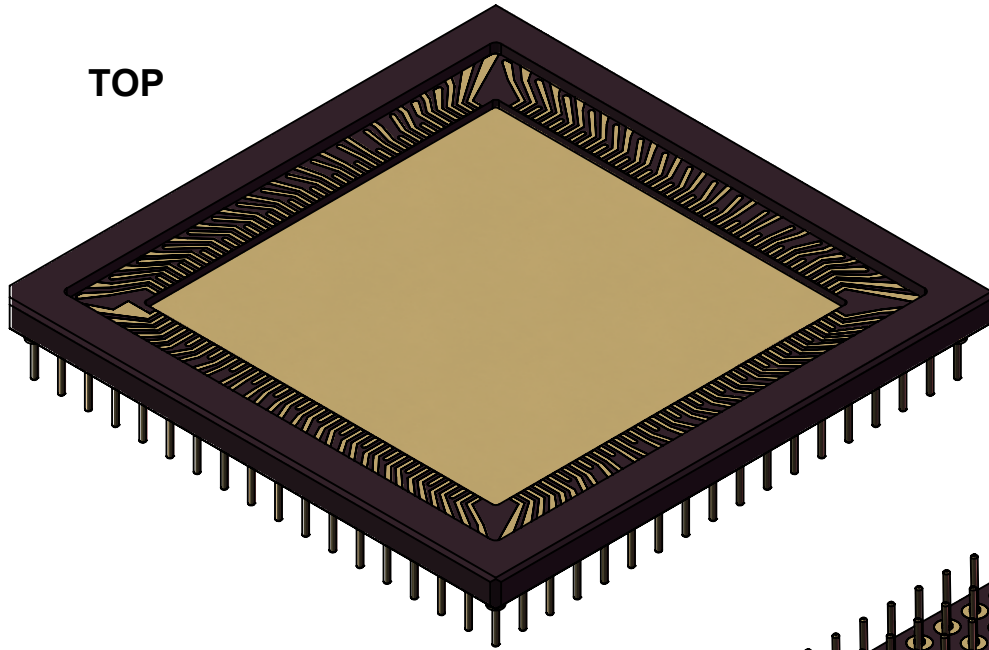

BOTTOM

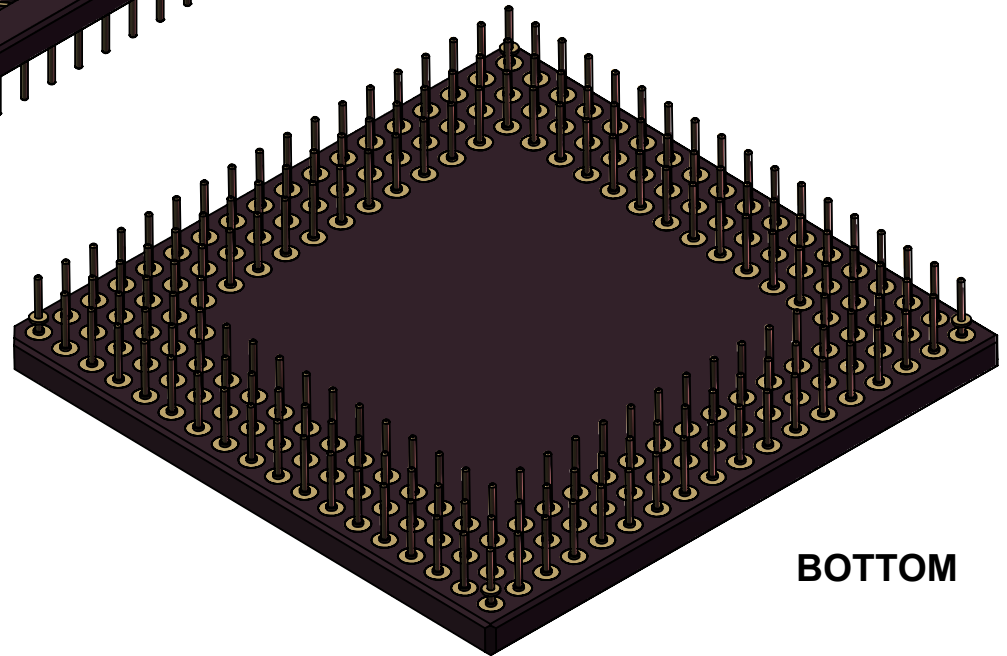

**TopLine**<sup>®</sup>

TITLE CPGA181T18x18-N1300  
CERAMIC PIN GRID ARRAY

SCALE 2:1	SIZE A	DRAWING NO. 183534	REV A
--------------	-----------	-----------------------	----------

DO NOT SCALE DRAWING

SHEET 5 OF 5