

**TOP VIEW**

**BOTTOM VIEW**

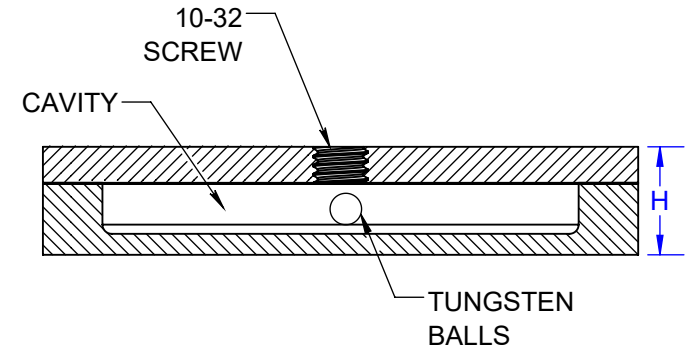
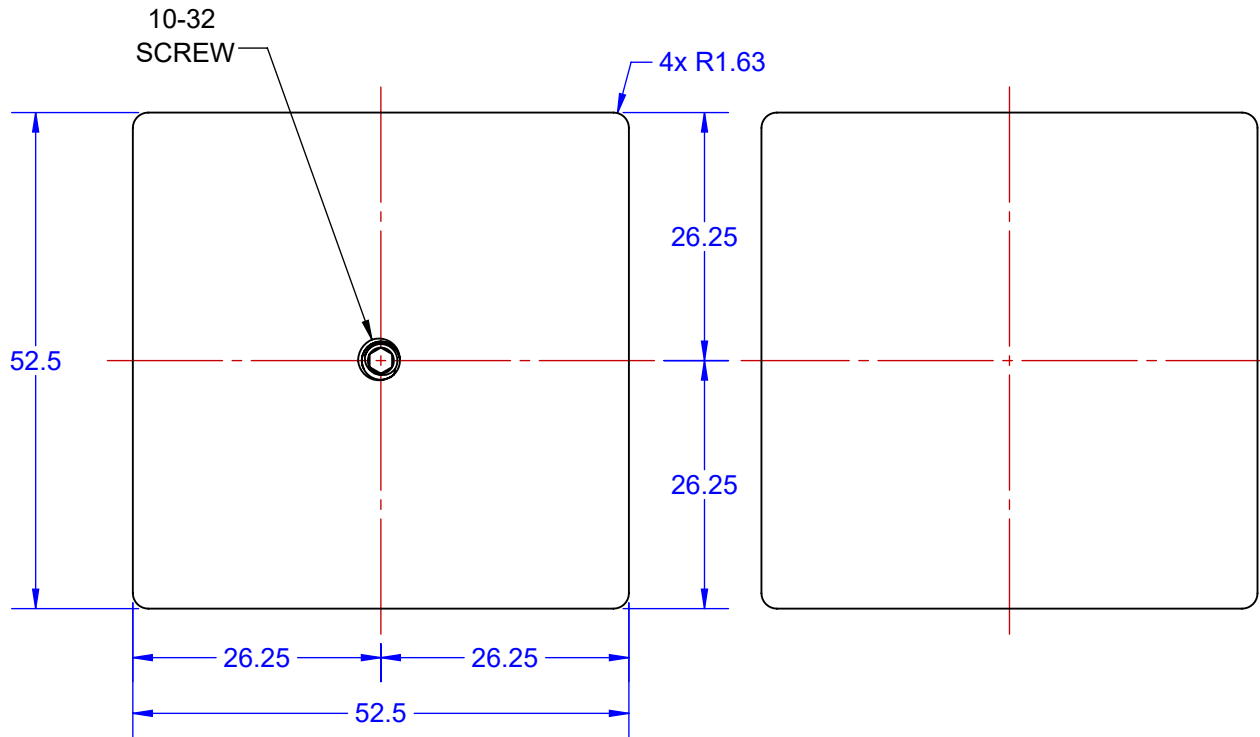

**SECTION VIEW**

**MODEL**

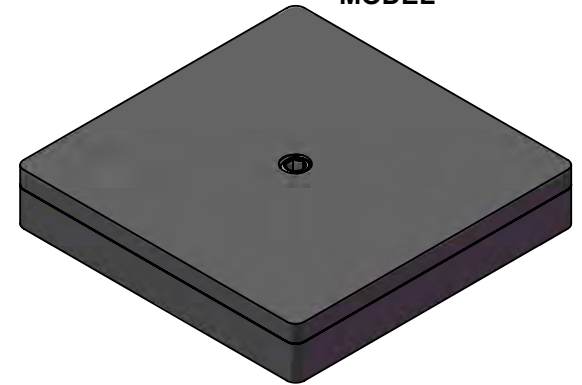

**U.S. PATENTS 10041558,  
10021779, 10704639,  
10704639, D842351**

**DIMENSION AND WEIGHT (MASS) TABLE**

H HEIGHT ±10%	PCB MASS NOM	TUNGSTEN BALLS IN CAVITY				Est. PID MASS	SCREW ADJUST	SCREW HEX HEAD
		∅ DIA	Per Ball	QTY	MASS			
9.5mm	450g	4mm	0.58g	~80	45g	~90g	10-32	3/32"

NOTES: (Unless Otherwise Specified).

1. DIMENSIONS: mm.
2. MOUNTING: Glue or Adhesive.
3. Alternative mounting screws. See DWG 120451

APPROVALS	DATE	<b>TopLine®</b>			
DRAWN T. Au	7/10/2024				
ENG M. Hart	7/10/2024	TITLE FA45SQ52.5x9.5A PID VIBRATION DAMPER			
MFG		SCALE	SIZE	DRAWING NO.	REV
QA		1.25:1	A	130452	A
CUST		DO NOT SCALE DRAWING			SHEET 1 OF 9
REVISED					

# MODEL

TOP

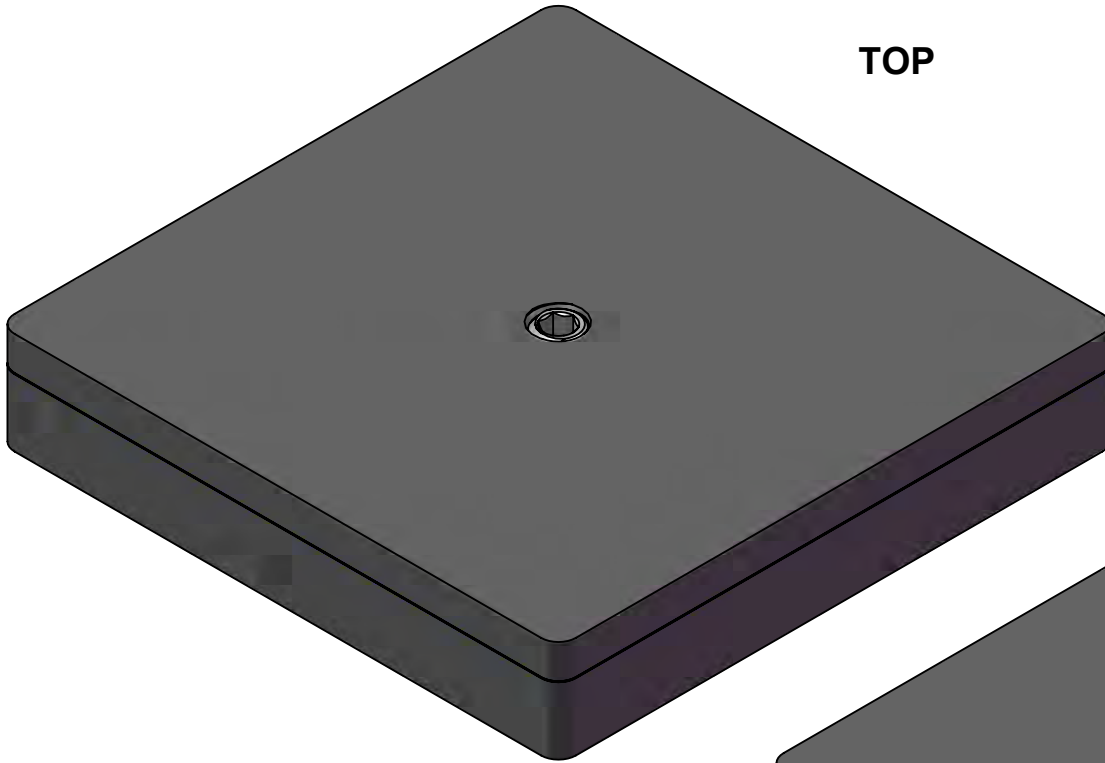

BOTTOM

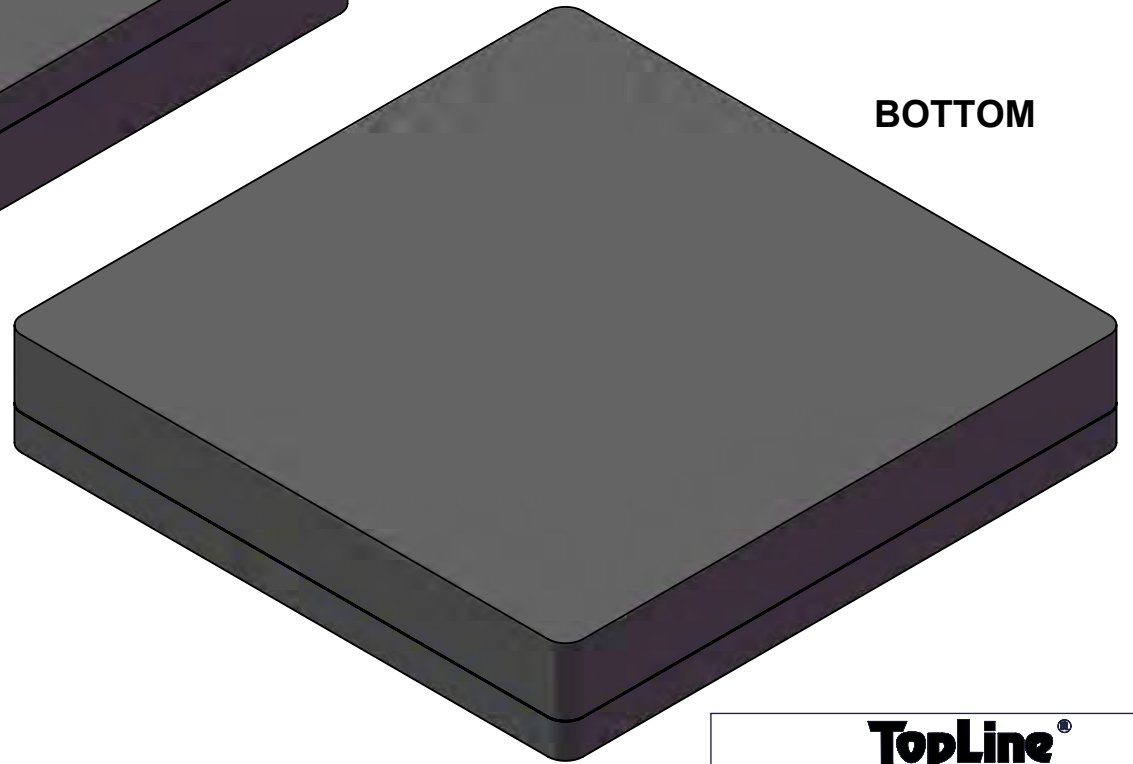

**NOTES:**

1. CONTACT TOPLINE FOR OTHER MOUNTING OPTIONS.

**TopLine**<sup>®</sup>

TITLE FA45SQ52.5x9.5A  
PID VIBRATION DAMPER

SCALE 2:1	SIZE A	DRAWING NO. 130452	REV A
--------------	-----------	-----------------------	----------

DO NOT SCALE DRAWING

SHEET 2 OF 9

<u>F</u>	<u>A</u>	<u>45</u>	<u>SQ</u>	<u>52.5x</u>	<u>9.5</u>	<u>A</u>
Series	Mounting on PCB	Tungsten Payload Grams	Exterior Shape	XY Size	Height	Version/Option
<b>Filled</b>	<b>Mounting Style</b>	<b>Code Grams</b>	<b>Code Shape</b>	<b>Code Size</b>	<b>Code Height</b>	<b>Code Version</b>
F = FR4	A = ADHESIVE GLUE  S = SCREW MOUNT	45 = 45gm  Other Mass Available	SQ Square R Rectangle C Cylindrical T Toroid Z Custom	52.5X = 52.5mm SQ  Other Sizes Available	9.5 = 9.5mm  Other Sizes Available	A = STANDARD  Other Version Available

### Order Number

<u>1</u>	<u>3</u>	<u>045</u>	<u>2</u>
DESCRIPTION	Mount Style	Mass (gm) 9 = Decimal	Option Code
<u>Code</u> <u>Description</u>	<u>Code</u> <u>Description</u>	<u>Code</u> <u>MASS</u>	<u>Code</u> <u>Option</u>
1 = Filled PID	2 = Screw 3 = Adhesive 9 = Custom 0 = Master DWG	045 = 45 gm	2 = VERSION B

**TopLine®**

TITLE      FA45SQ52.5x9.5A  
PID VIBRATION DAMPER

SCALE NONE	SIZE A	DRAWING NO. 130452	REV A
---------------	-----------	-----------------------	----------