

TOP VIEW

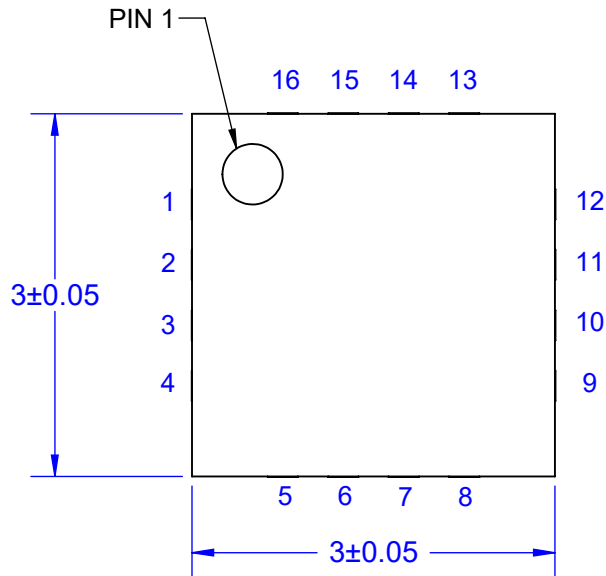

SIDE VIEW

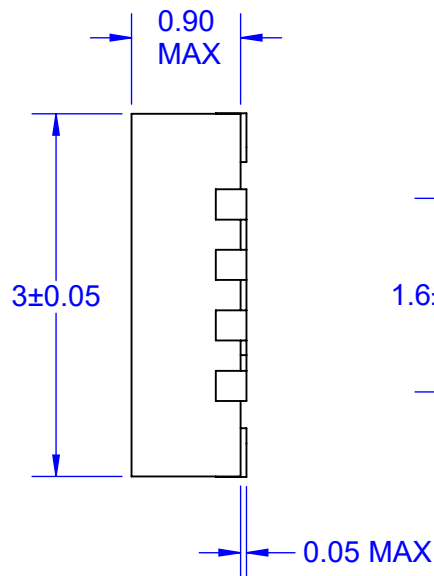

BOTTOM VIEW

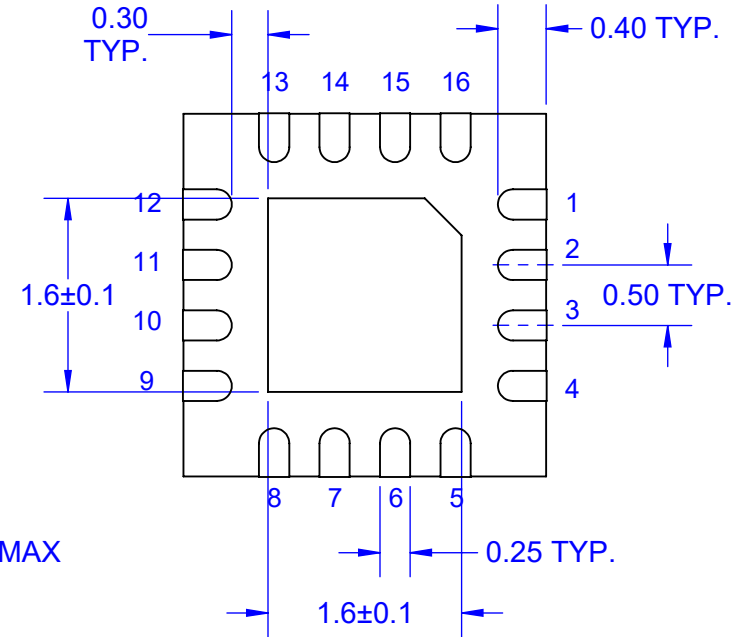

MODEL

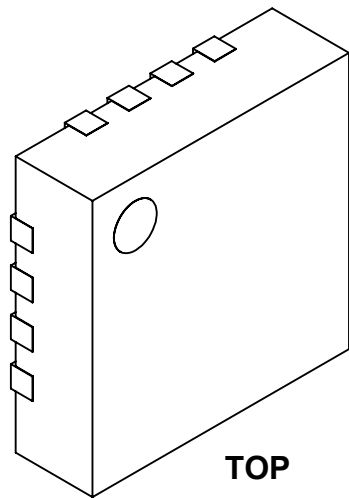

TOP

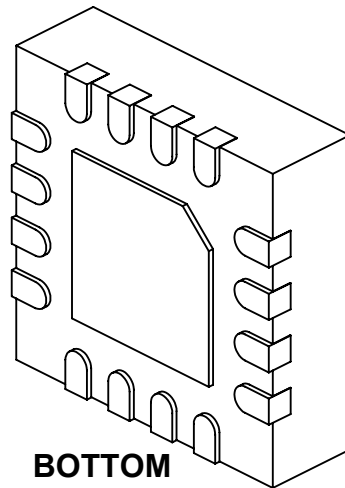

BOTTOM

Notes: (Unless Otherwise Specified).

- 1) BODY: PLASTIC, SEMICONDUCTOR GRADE.
- 2) LEAD FRAME: COPPER, C-194 F/H.
- 3) LEAD FRAME PLATING: Sn MATTE TIN.
- 4) FRAME THICKNESS: 0.203mm.
- 5) DIE PAD: 1.6 X 1.6 mm EXPOSED BOTTOM.
- 6) JEDEC OUTLINE: MO-220.
- 7) DIMENSIONS IN mm.

APPROVALS	DATE	TopLine®			
DRAWN T. Au	7/28/2021				
ENG M. Hart	7/28/2021	TITLE 16-LEAD 3mm P0.5mm QFN DAISY CHAIN			
MFG		SCALE	SIZE	DRAWING NO.	REV
QA		16:1	A	451644	A
CUST		DO NOT SCALE DRAWING			SHEET 1 OF 5
REVISED					

DAISY CHAIN PATTERN

TOP VIEW

SIDE VIEW

BOTTOM VIEW

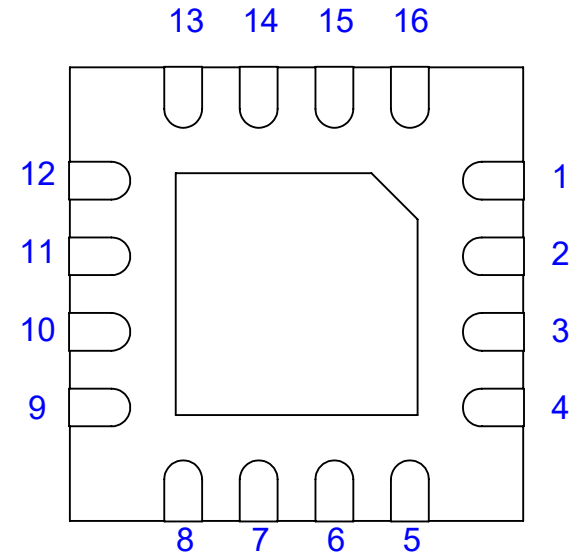
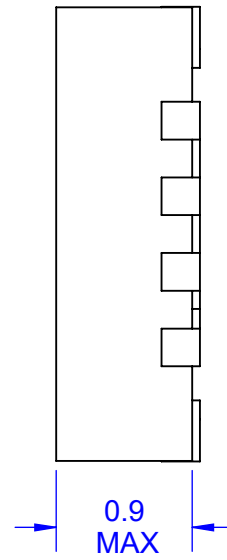
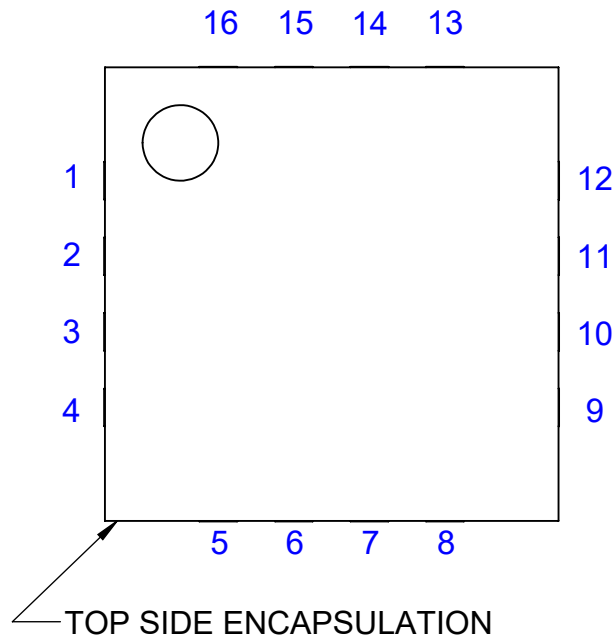

NOTE:
1. PACKAGE DAISY CHAIN BY WIRE BONDING TO INTERNAL BOND PADS.

TopLine®			
TITLE 16-LEAD 3mm P0.5mm QFN DAISY CHAIN			
SCALE 20:1	SIZE A	DRAWING NO. 451644	REV A
DO NOT SCALE DRAWING			SHEET 2 OF 5

16L QFN DAISY CHAIN TOP VIEW

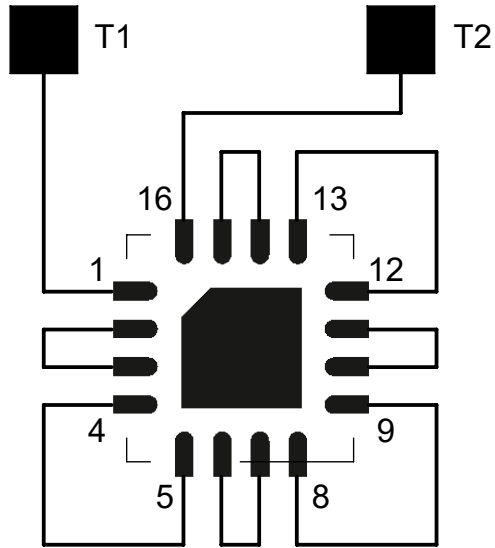

**RECOMMENDED
PCB PADS**

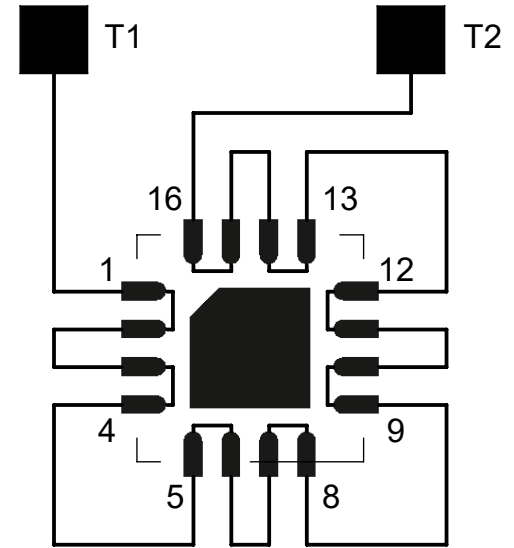

**AFTER MOUNTING
ON PCB**

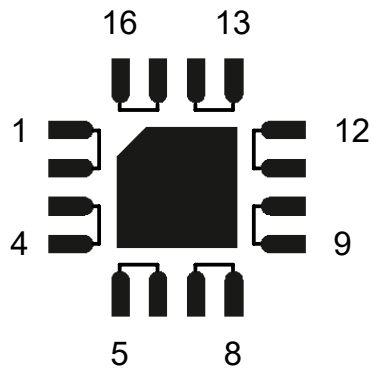

VIEW FROM TOP

DAISY CHAIN NET LIST

PINS	PINS
1 ~ 2	3 ~ 4
5 ~ 6	7 ~ 8
9 ~ 10	11 ~ 12
13 ~ 14	15 ~ 16

TopLine®

TITLE 16-LEAD 3mm P0.5mm
QFN DAISY CHAIN

SCALE 10:1	SIZE A	DRAWING NO. 451644	REV A
---------------	-----------	-----------------------	----------

DO NOT SCALE DRAWING

SHEET 3 OF 5

PART NUMBERING SYSTEM

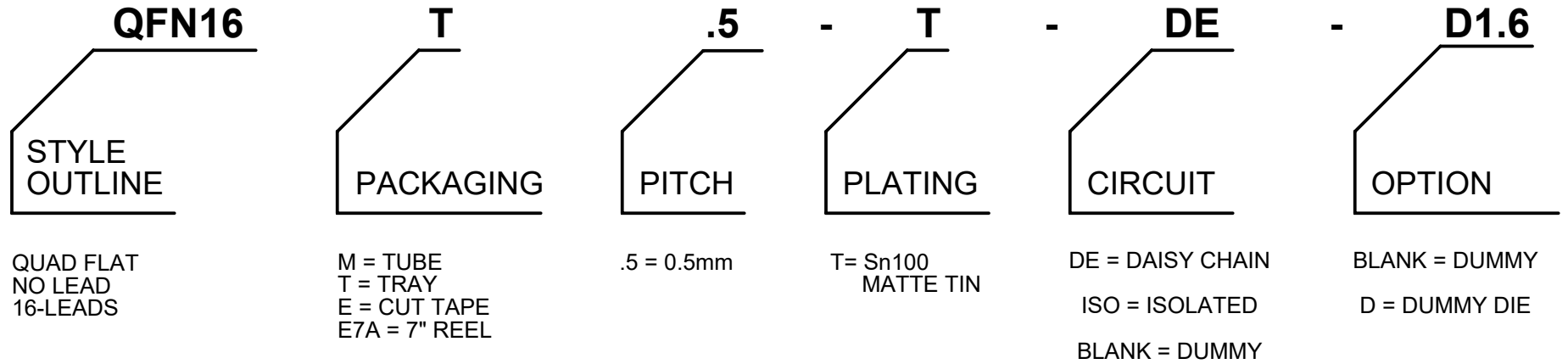

PART NUMBER	DAISY CHAIN	PACKAGING	RoHS Pb-FREE	Plating	DUMMY DIE
QFN16T.5-T-DE-D1.6	YES	JEDEC TRAY	YES	Sn100	YES
QFN16E7A.5-T-DE-D1.6	YES	TAPE & REEL	YES	Sn100	YES
QFN16E.5-T-DE-D1.6	YES	CUT TAPE	YES	Sn100	YES
QFN16E7A.5-T-ISO	ISOLATED	JEDEC TRAY	YES	Sn100	NO

OTHER PART NUMBER COMBINATIONS AVAILABLE. CONTACT TOPLINE.

TopLine®			
TITLE 16-LEAD 3mm P0.5mm QFN DAISY CHAIN			
SCALE NONE	SIZE A	DRAWING NO. 451644	REV A
DO NOT SCALE DRAWING			SHEET 5 OF 5