

TOP VIEW

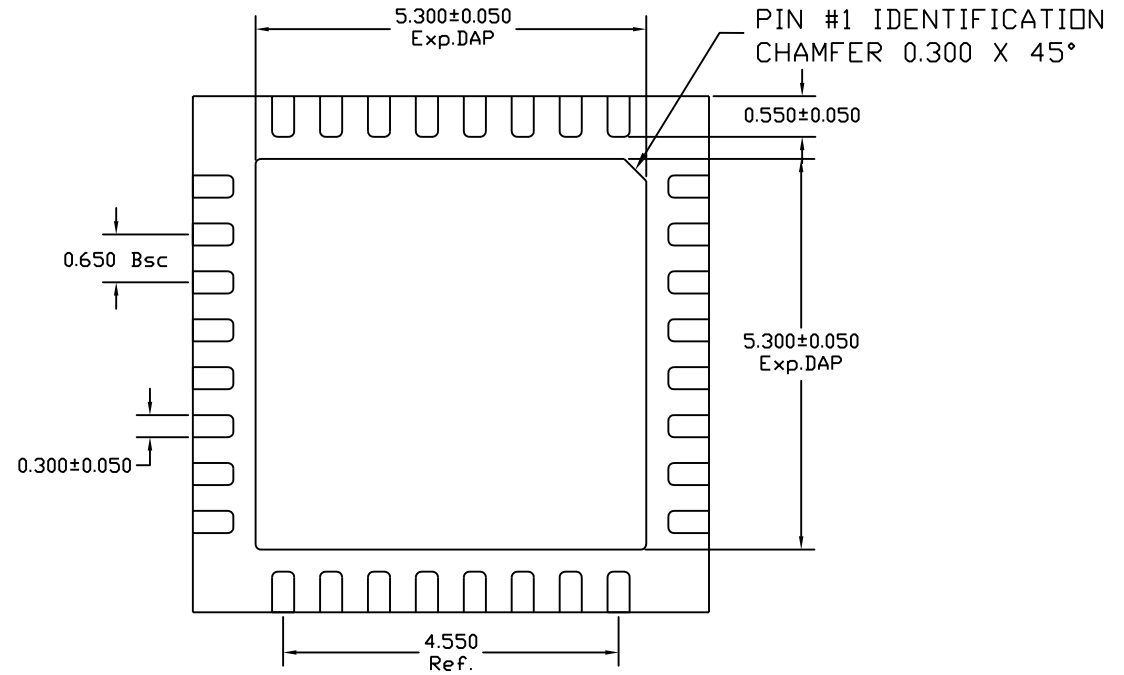

BOTTOM VIEW

NOTE:

1) TSLP AND SLP SHARE THE SAME EXPOSE OUTLINE BUT WITH DIFFERENT THICKNESS:

A		TSLP	SLP
	MAX.	0.800	0.900
NOM.	0.750	0.850	
MIN.	0.700	0.800	

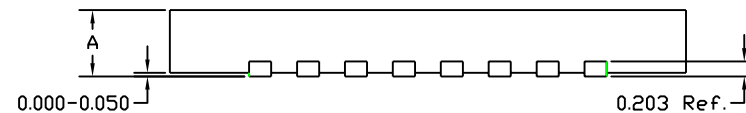

SIDE VIEW

DESIGNED: ANDREW TAN	
APPD: CW CHAI	
APPD: GC TAN	
APPD: RIZAL	
APPD: WH LAI	DATE: _____
DWG. NO: PO-32(T/SLP)7X7-5.30X5.30	REV.: 02

7x7 mm
(PACKAGE OUTLINE)

SHEET NO

TOLERANCES

REFER TO SPECIFICATION A

UNIT:	SCALE:
MM	NTS
SYMBOL	

		13/02/06	ANDREW	CE
		17/04	BENJAMIN	CE
REV.	DESCRIPTION	DATE	BY	APPD