

PSSO36 (slug up) mechanical outline

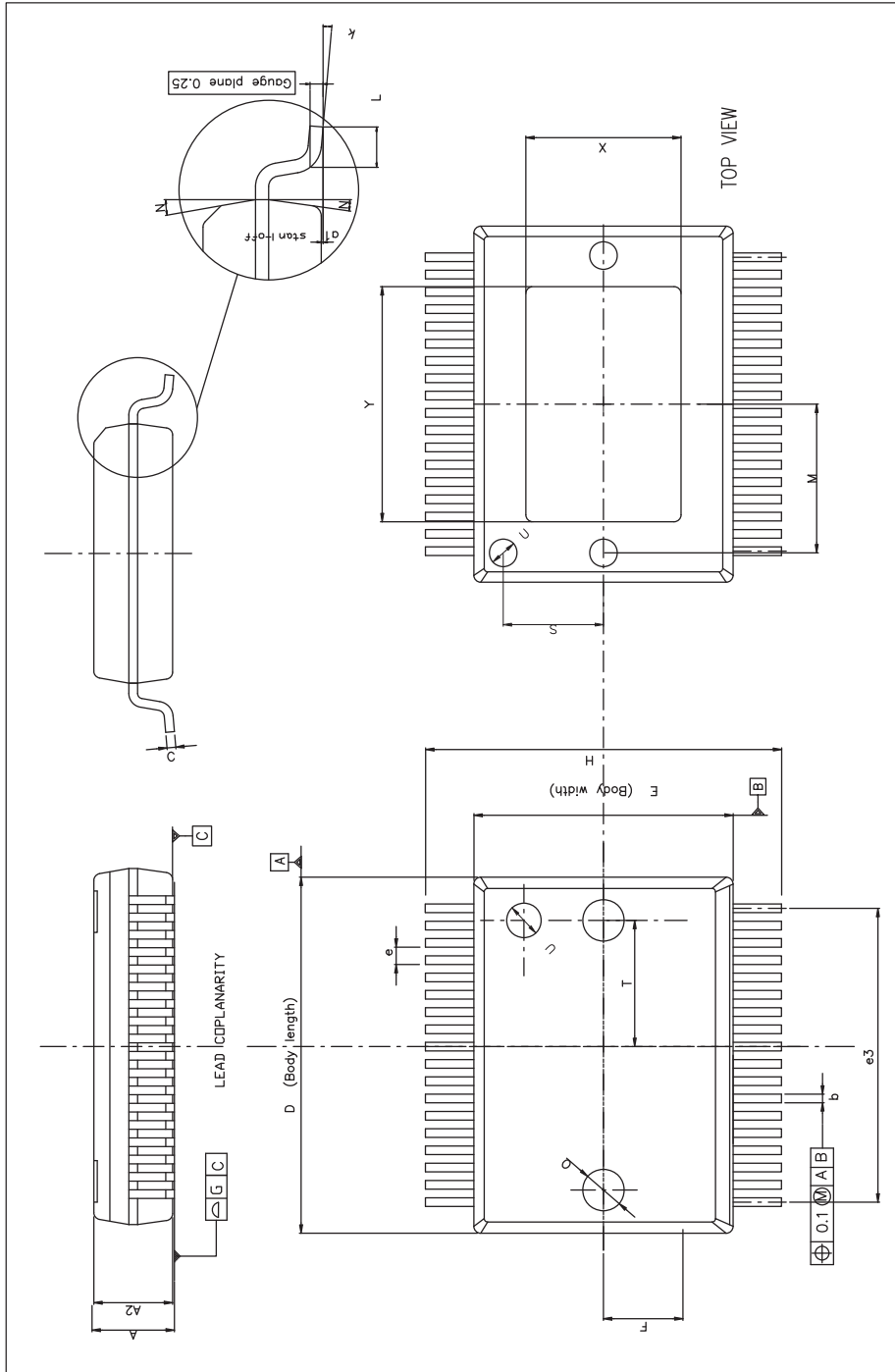

PSSO36 Exposed Pad up dimensions

Symbol	Dimensions in mm.			Dimensions in inch.		
	Min.	Typ.	Max.	Min.	Typ.	Max.
A	2.15	-	2.45	0.085	-	0.096
A2	2.15	-	2.35	0.085	-	0.092
a1	0	-	0.1	0.00	-	0.004
b	0.18	-	0.36	0.007	-	0.014
c	0.23	-	0.32	0.009	-	0.013
D	10.10	-	10.50	0.398	-	0.413
E	7.4	-	7.6	0.291	-	0.299
e	-	0.5	-	-	0.020	-
e3	-	8.5	-	-	0.335	-
F	-	2.3	-	-	0.091	-
G	-	-	0.1	-	-	0.004
H	10.1	-	10.5	-	-	0.413
h	-	-	0.4	-	-	0.016
k	0 deg	-	8 deg	0 deg	-	8 deg
L	0.55	-	0.85	0.022		0.033
M	-	4.3	-	-	0.169	-
N	-	-	10 deg	-	-	10 deg
O	-	1.2	-	-	0.047	-
Q	-	0.8	-	-	0.031	-
S	-	2.9	-	-	0.114	-
T	-	3.65	-	-	0.114	-
U	-	1.0	-	-	0.039	-