

## TOP VIEW

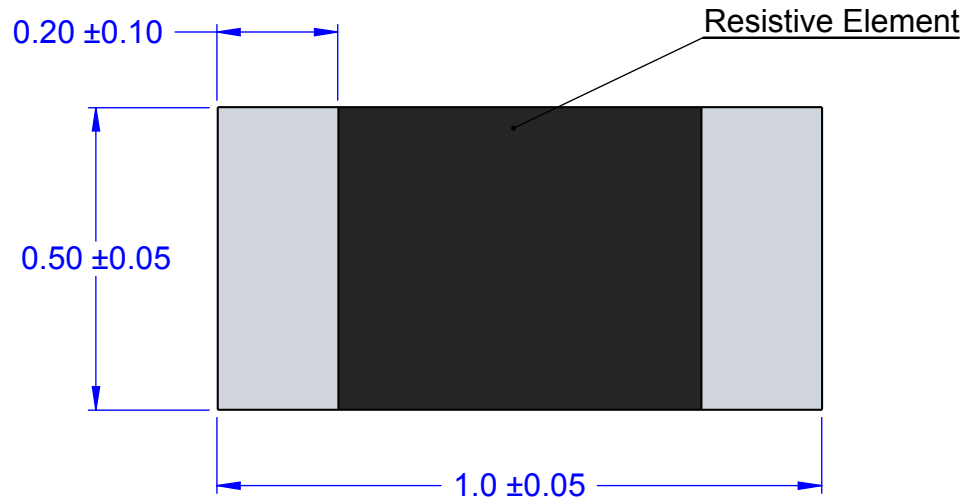

## RECOMMENDED PCB PATTERN

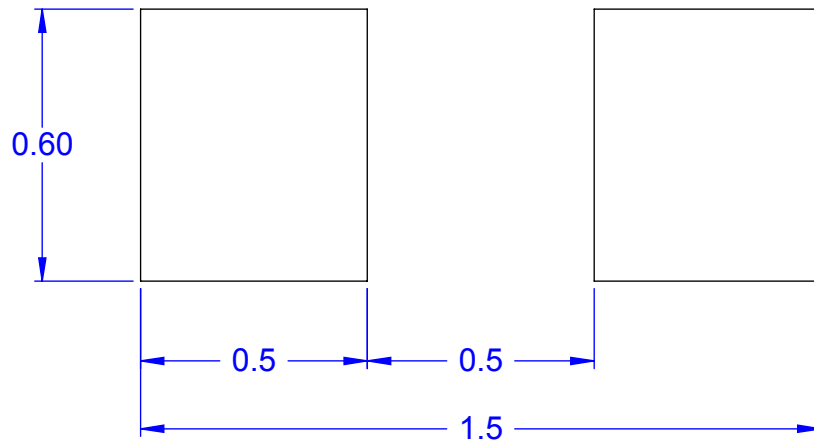

PCB DIMENSIONS ARE PRESENTED ONLY AS A GUIDELINE. DESIGNERS SHOULD USE THEIR OWN KNOWLEDGE BASE WHEN DESIGNING THE PCB.

## STRUCTURE

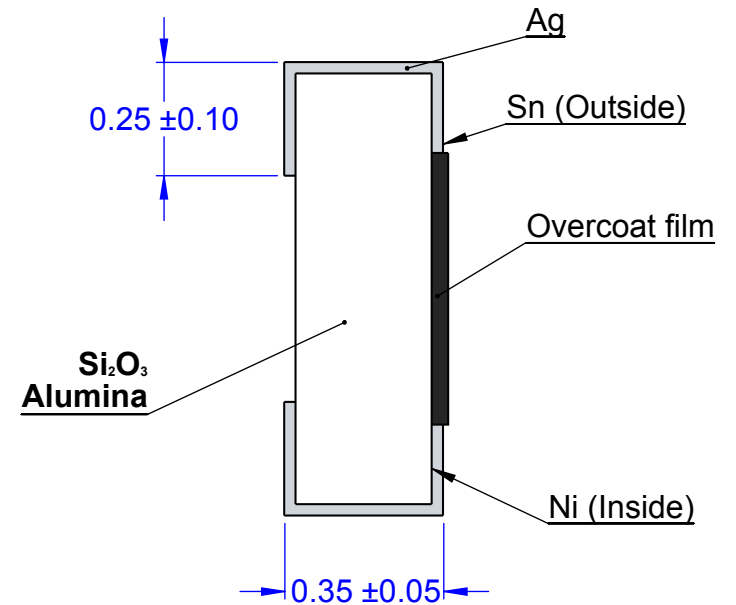

NOTES: Current Rating 1A @ 50WVDC

1. DIMENSIONS IN mm.
2. TERMINATION: Tin (Sn).
3. Pb-FREE AND HALOGEN FREE.

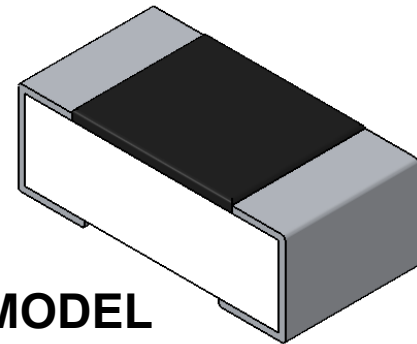

## MODEL

APPROVALS	DATE	<b>TopLine®</b>			
DRAWN T. Au	08/03/12				
ENG M. Hart	08/03/12	TITLE SR0402 SMT RESISTOR			
MFG		SCALE	SIZE A	DRAWING NO. 120401	REV A
QA					
CUST		DO NOT SCALE DRAWING			SHEET 1 OF 2
REVISED					

# W8P2 CARRIER TAPE DIMENSION

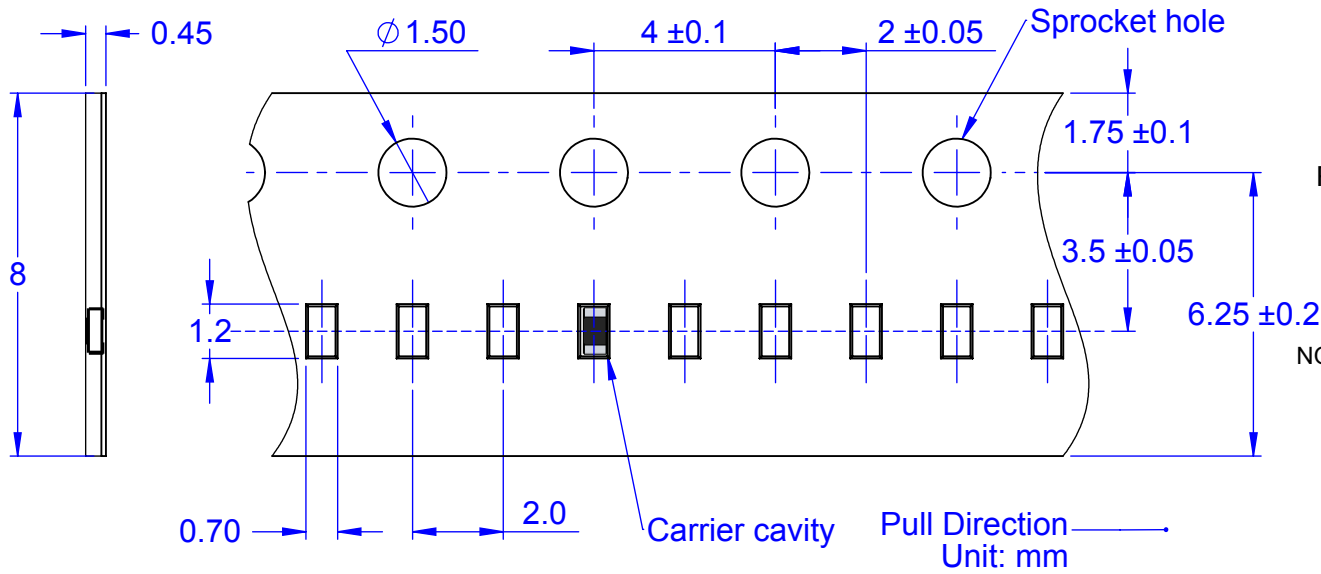

## PART NUMBER SYSTEM

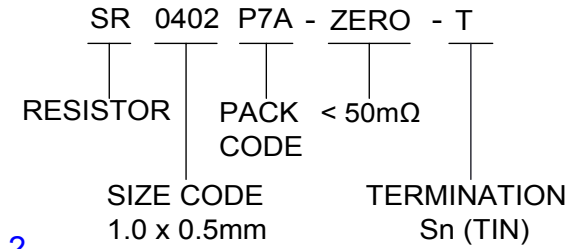

NOTE: For dummy resistor replace ZERO with blank

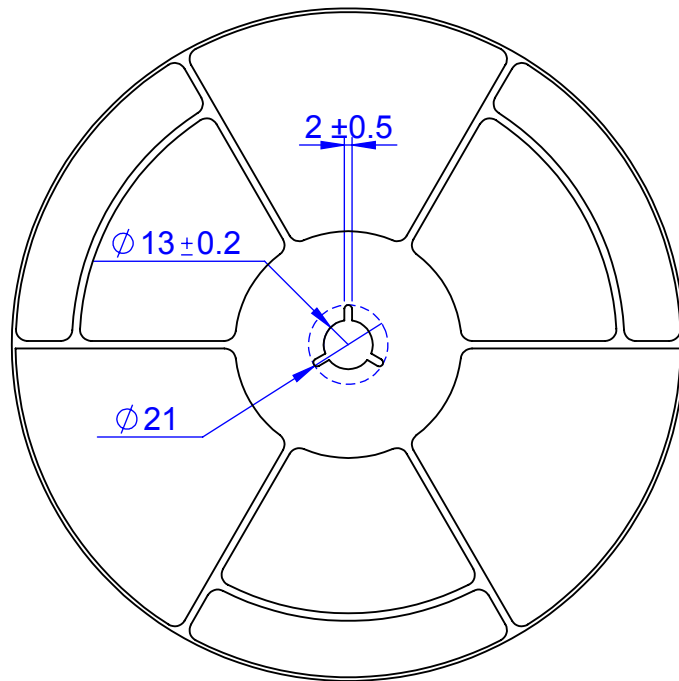

## REEL DIMENSIONS

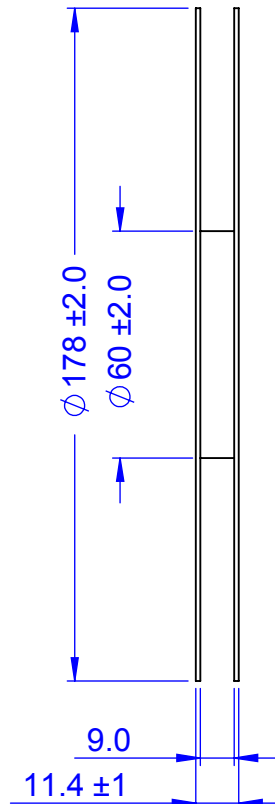

PACK CODE		
CODE	QTY	PACKAGE
P7A	10,000	REEL
P4A	1,000	REEL

APPROVALS	DATE				
DRAWN T. Au	06/22/12				
ENG M. Hart	06/22/12	TITLE SR0402 SMT RESISTOR			
MFG		SCALE	SIZE A	DRAWING NO.	REV
QA				120401	A
CUST		DO NOT SCALE DRAWING			SHEET 2 OF 2
REVISED					