

TOP VIEW

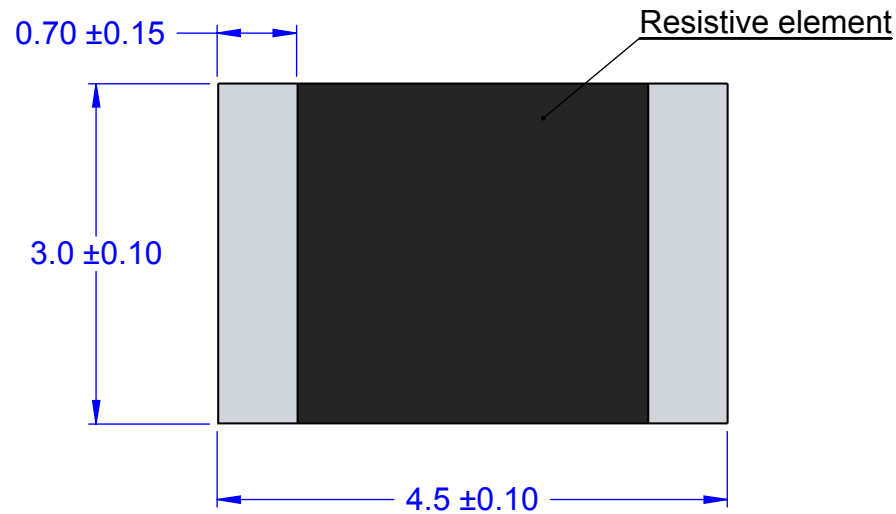

RECOMMENDED PCB PATTERN

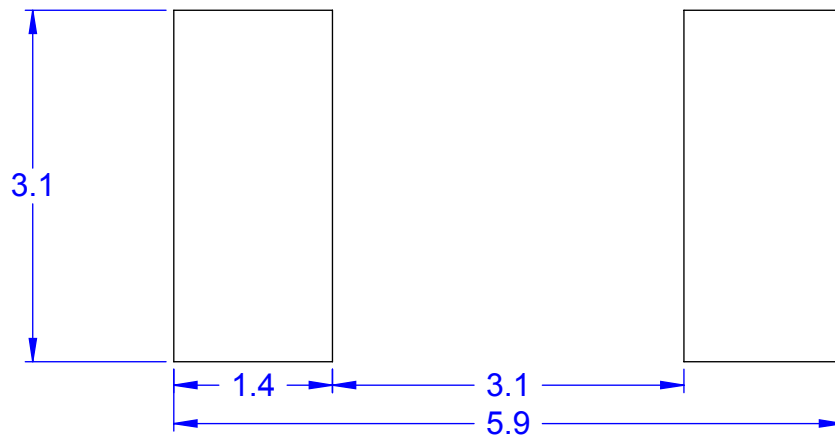

PCB DIMENSIONS ARE PRESENTED ONLY AS A GUIDELINE. DESIGNERS SHOULD USE THEIR OWN KNOWLEDGE BASE WHEN DESIGNING THE PCB.

STRUCTURE

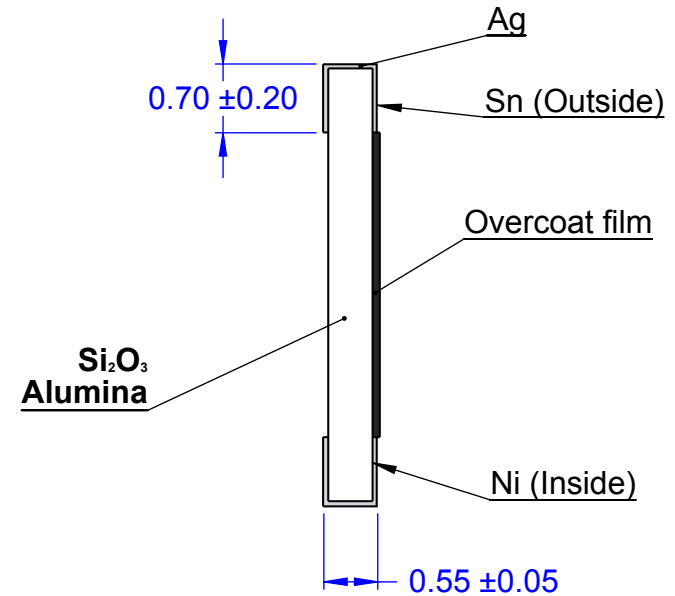

NOTES: Current Rating 2A @ 100WVDC

1. DIMENSIONS IN mm.
2. TERMINATION: Tin (Sn).
3. Pb-FREE AND HALOGEN FREE.

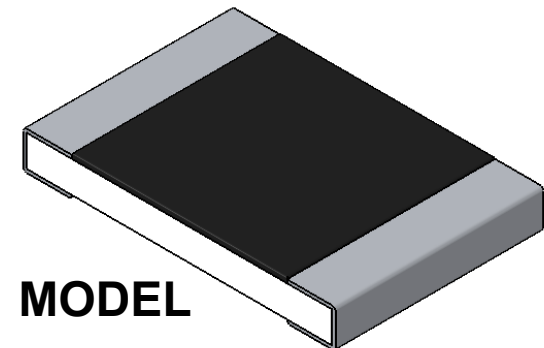

MODEL

APPROVALS		DATE				
DRAWN	T. Au	11/29/12				
ENG	M. Hart	11/29/12	SCALE		SIZE	DRAWING NO.
MFG					A	121812
QA						REV
CUST						A
REVISED			DO NOT SCALE DRAWING			SHEET 1 OF 2

W12P4 CARRIER TAPE DIMENSION

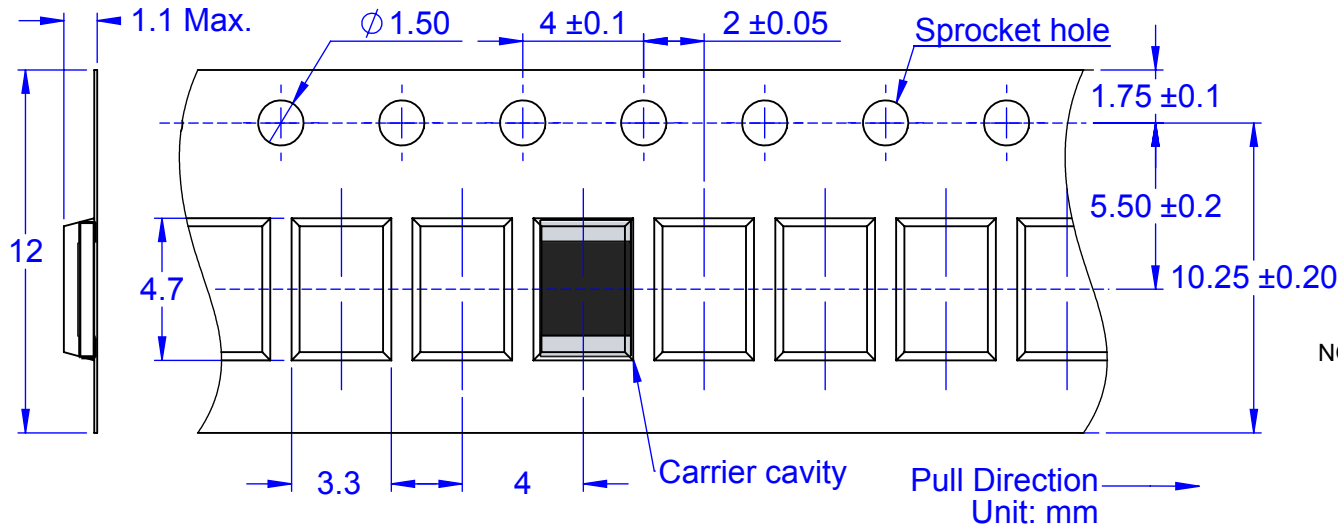

PART NUMBER SYSTEM
 SR 1812 E7A - ZERO - T
 RESISTOR PACK CODE < 50mΩ
 SIZE CODE TERMINATION
 4.5 x 3.0mm Sn (TIN)
 NOTE: For dummy resistor replace ZERO with blank

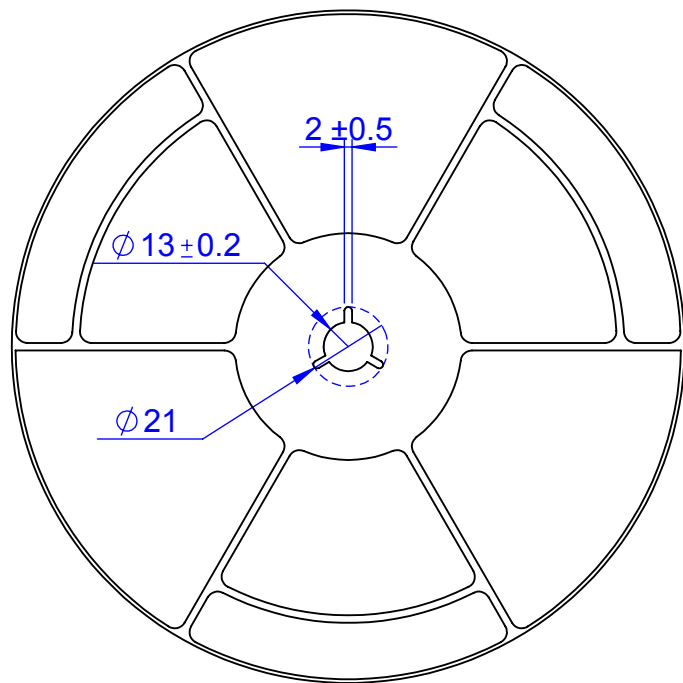

REEL DIMENSIONS

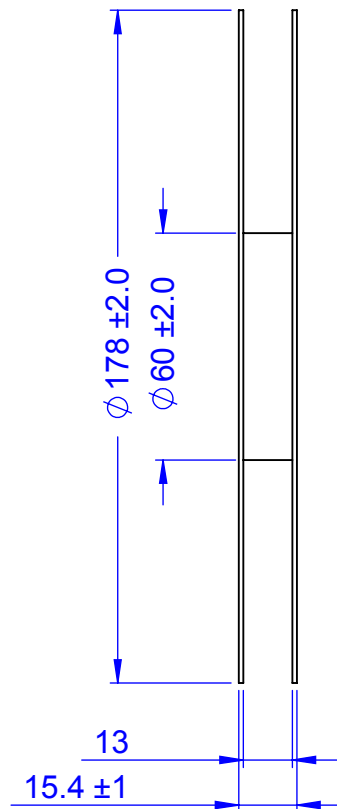

PACK CODE		
*CODE	QTY	PACKAGE
E7A	4,000	REEL
E4A	500	REEL

APPROVALS	DATE	TopLine®			
DRAWN T. Au	11/29/12				
ENG M. Hart	11/29/12	TITLE SR1812 SMT RESISTOR			
MFG		SCALE	SIZE A	DRAWING NO.	REV
QA				121812	A
CUST		DO NOT SCALE DRAWING			SHEET 2 OF 2
REVISED					