

ITEM	NAME	MATERIAL / COMPOSED PARTS	QTY
1	LID	Fe-Ni-Co ALLOY	1

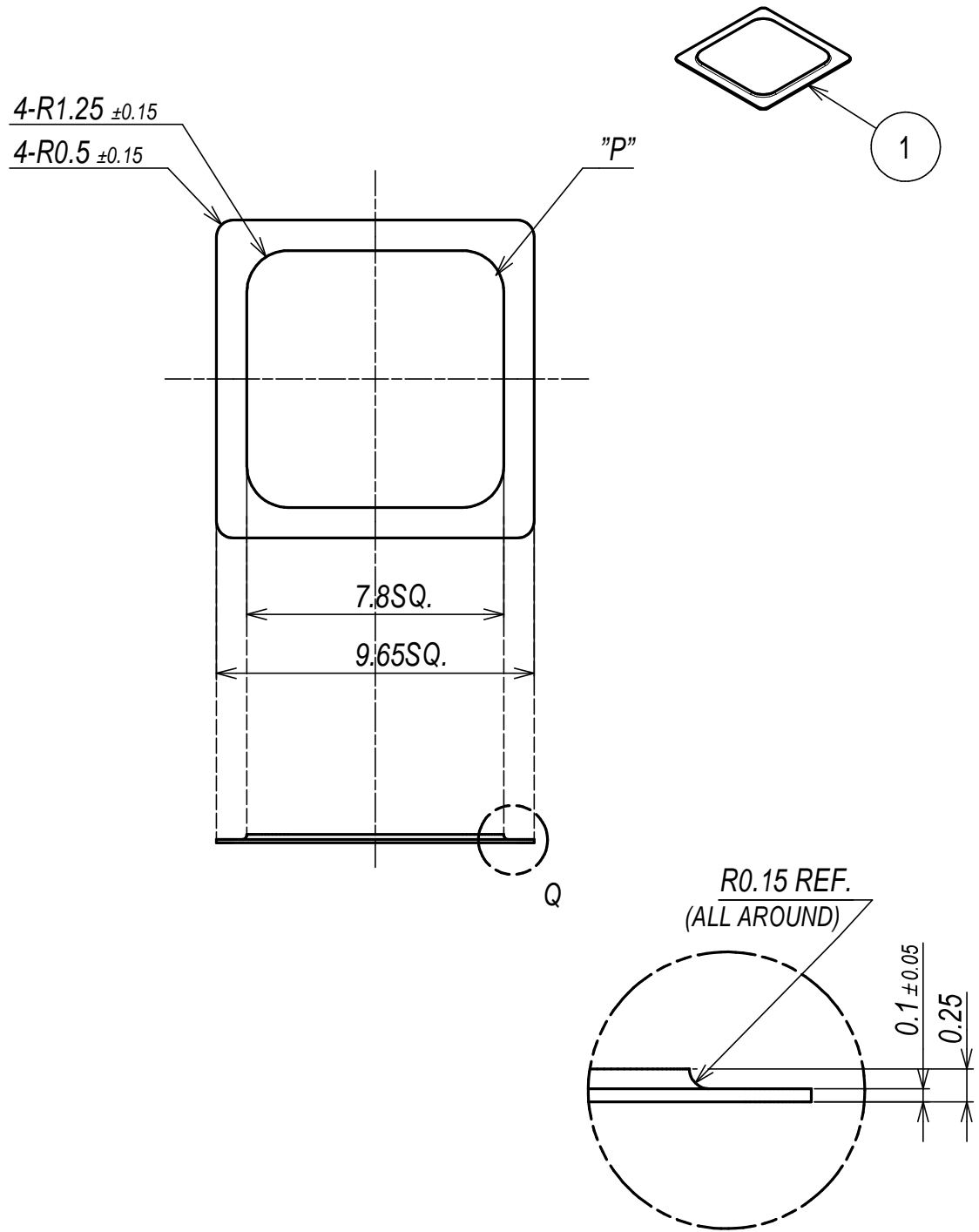

**NOTES**

1. FINISH: Ni PLATE + Au PLATE 1.0  $\mu$ mMIN.  
PLATING THICKNESS MEASURED ON POINT 'P'.
2. NO BLISTERS ON Au AFTER 3MINUTES (IN AIR OVEN) AT 400°C AS SEEN UNDER 10X MAGNIFICATION.
3. PLATING RACK POINT MARKS TO BE PERMITTED ON ALL AROUND EDGES. (NOT APPLY NOTE.1,2)
4. GENERAL SPECIFICATION: MS-1001(LATEST VERSION)  
VISUAL INSPECTION SPECIFICATION: MDS-1001(LATEST VERSION)

**DETAIL "Q"**  
(20 : 1)

NAME		UNITS mm
LID FOR RA6142		
TOLERANCES UNLESS OTHERWISE SPECIFIED	DWG No.	1 1
±0.12	PGMR-A9389	