

Matching Lid for DWG 121450

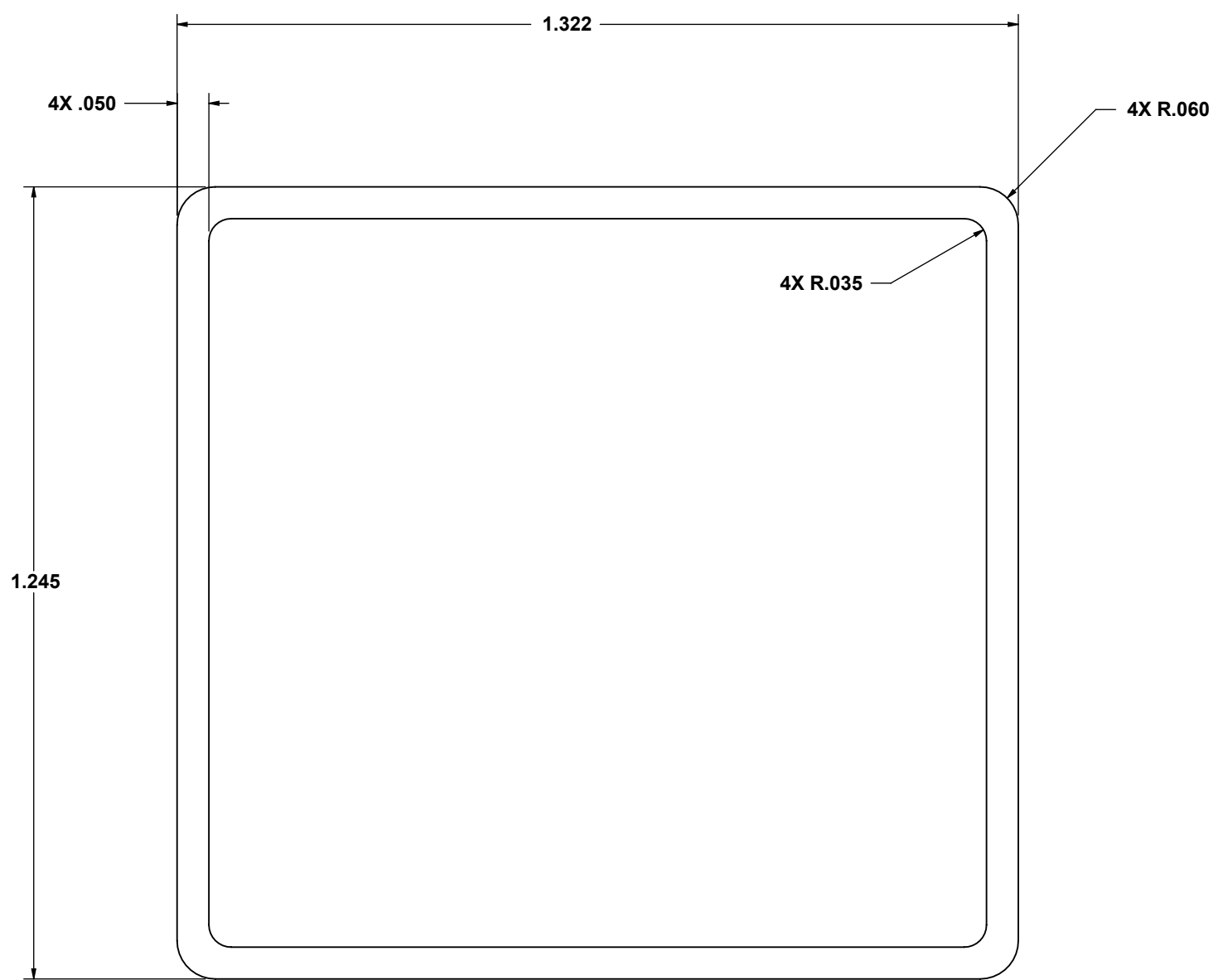

1. MATERIAL: ASTM F15 ALLOY KOVAR

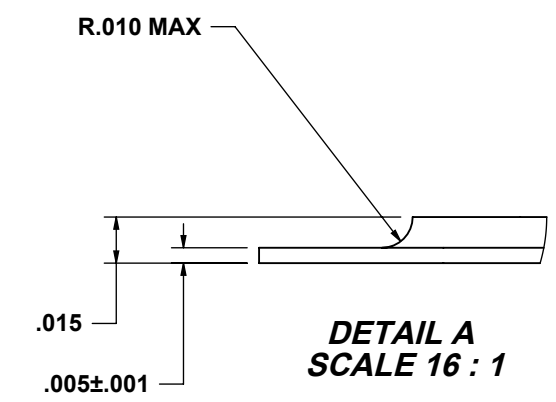

PLATING REQUIREMENTS						
	BODY/FRAME			LEADS		
	THICKNESS	TYPE	PER SPEC	THICKNESS	TYPE	PER SPEC
NICKEL	100-300 μ"	ELECTROLESS	MIL-C-26074	- μ"	ELECTROLESS	MIL-C-26074
	2.54-7.62 μm			- μm		
GOLD	100-MIN μ"	ELECTROLYTIC	MIL-G-45204 TYPE III, GRADE A	- μ"	ELECTROLYTIC	MIL-G-45204 TYPE III, GRADE A
	2.54-MIN μm			- μm		

UNLESS OTHERWISE SPECIFIED DIMENSIONS ARE IN INCHES		
TOLERANCES:		
2 PLACE DECIMALS ±	<b>.01</b>	
3 PLACE DECIMALS ±	<b>.003</b>	
ANGLES ±	<b>1°</b>	
FRACTIONS ±	<b>1/64</b>	
SURFACE FINISH (MAXIMUM)	<b>63</b>	

DRAWN BY	05/15/13	DWG NAME	<b>Step Lid SL1.245x1.322G</b>	
DESIGN ENG		DWG NUMBER	<b>169695</b>	
CHECKED BY				SHEET