

### TOP VIEW

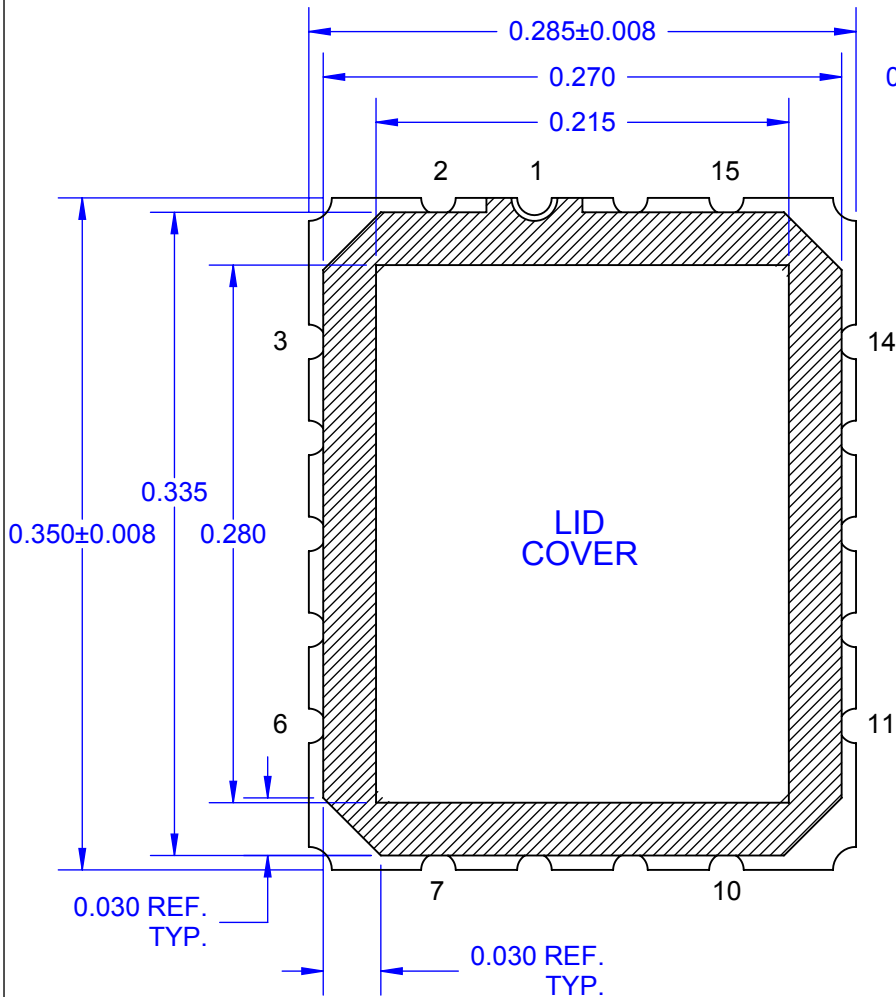

### SIDE VIEW

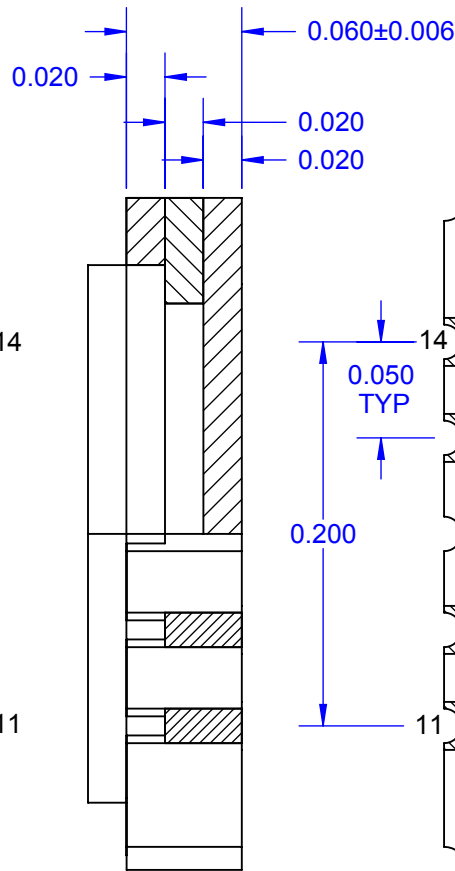

### BOTTOM VIEW

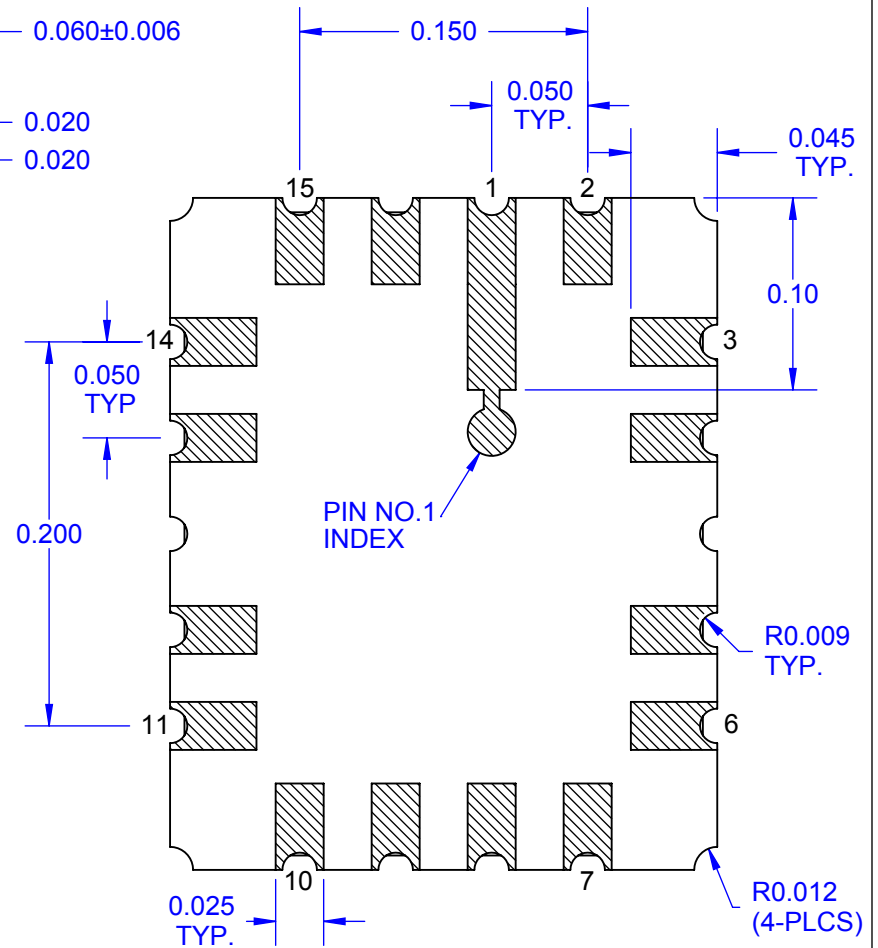

Notes: (Unless Otherwise Specified).

1) PLATING:

Ni 80 MICRO-INCH (2.0µm) MIN.

Au 60 MICRO-INCH (1.5µm) MIN.

2) DIMENSIONS in INCH (UNLESS SPECIFIED).

PART NUMBER	LID	PLATING	DAISY CHAIN
LCC16B50R.28x.35-N	OPEN	NiAu	NO
LCC16B50R.28x.35	SEALED	NiAu	NO
LCC16B50R.28x.35-SC	SEALED	SnPb	NO
LCC16B50R.28x.35-DE	SEALED	NiAu	YES
LCC16B50R.28x.35-DE-SC	SEALED	SnPb	YES

APPROVALS	DATE				
DRAWN T.Au	06/22/14				
ENG M. Hart	06/22/14	TITLE LCC16B50R.28x.35			
MFG		SCALE 10:1	SIZE A	DRAWING NO. 141600	REV A
QA		DO NOT SCALE DRAWING			SHEET 1 OF 2
CUST					
REVISED					

# LCC16B50R.28x.35-DE DAISY CHAIN

## TOP VIEW

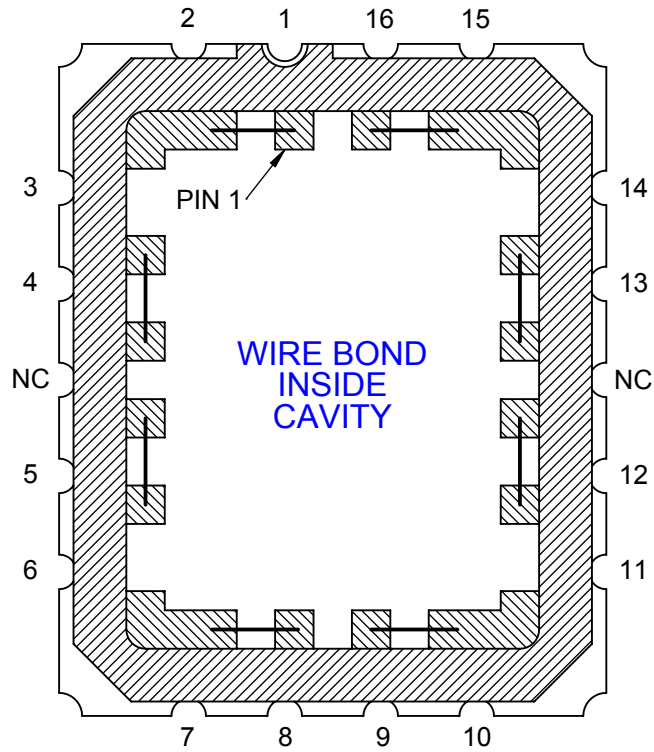

## BOTTOM VIEW

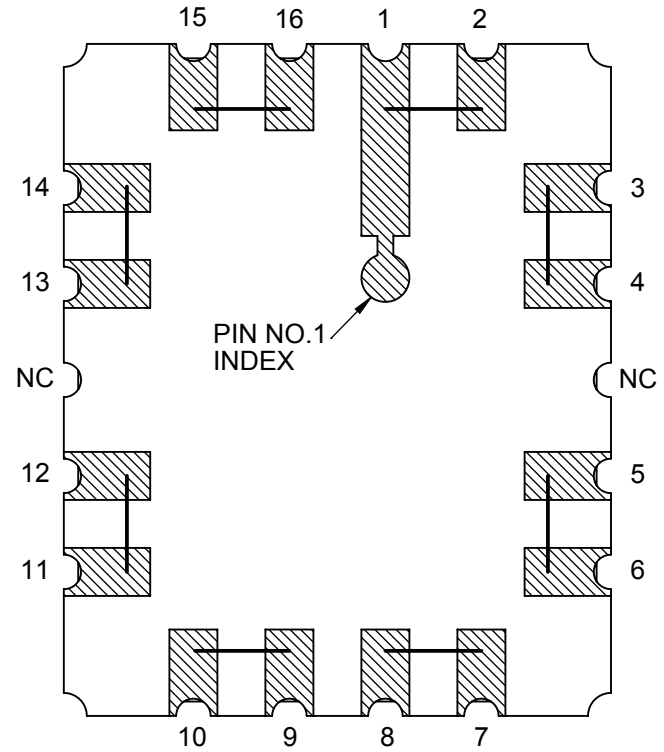

DAISY CHAIN NET LIST	
FROM / TO	FROM / TO
1 ~ 2	9 ~ 10
3 ~ 4	11 ~ 12
5 ~ 6	13 ~ 14
7 ~ 8	15 ~ 16

<b>TopLine®</b>			
TITLE LCC16B50R.28x.35			
SCALE 10:1	SIZE A	DRAWING NO. 141600	REV A
DO NOT SCALE DRAWING			SHEET 2 OF 2