

TOP VIEW

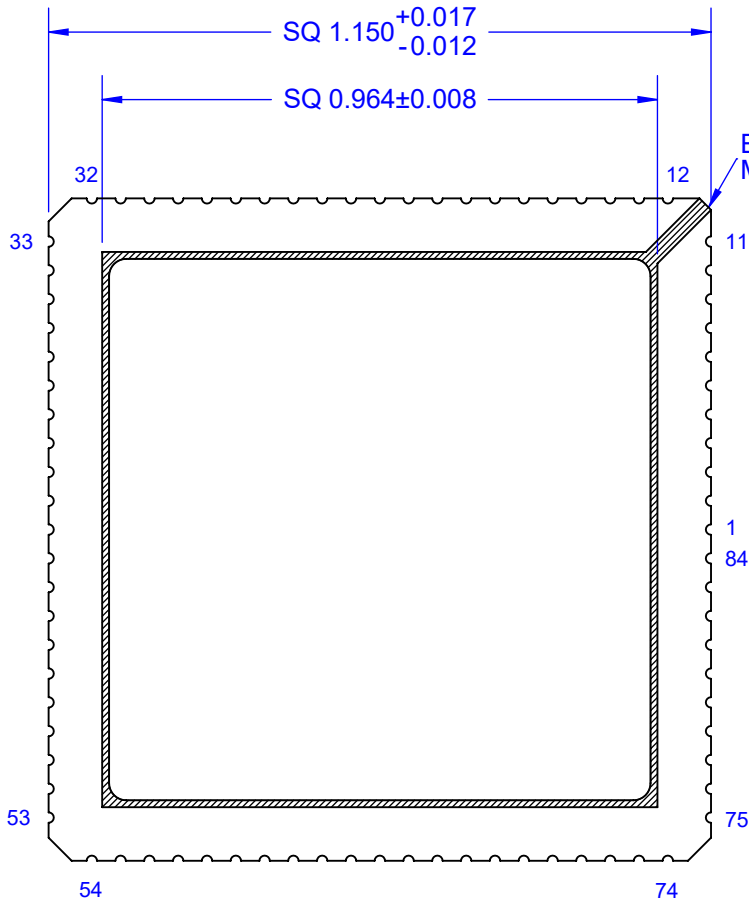

SIDE VIEW

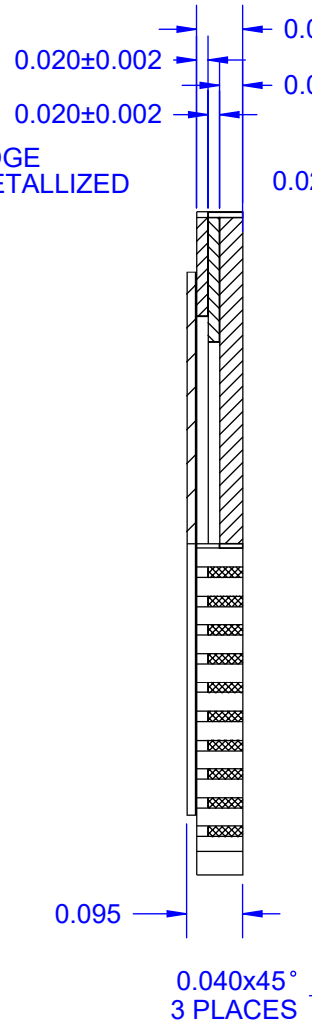

BOTTOM VIEW

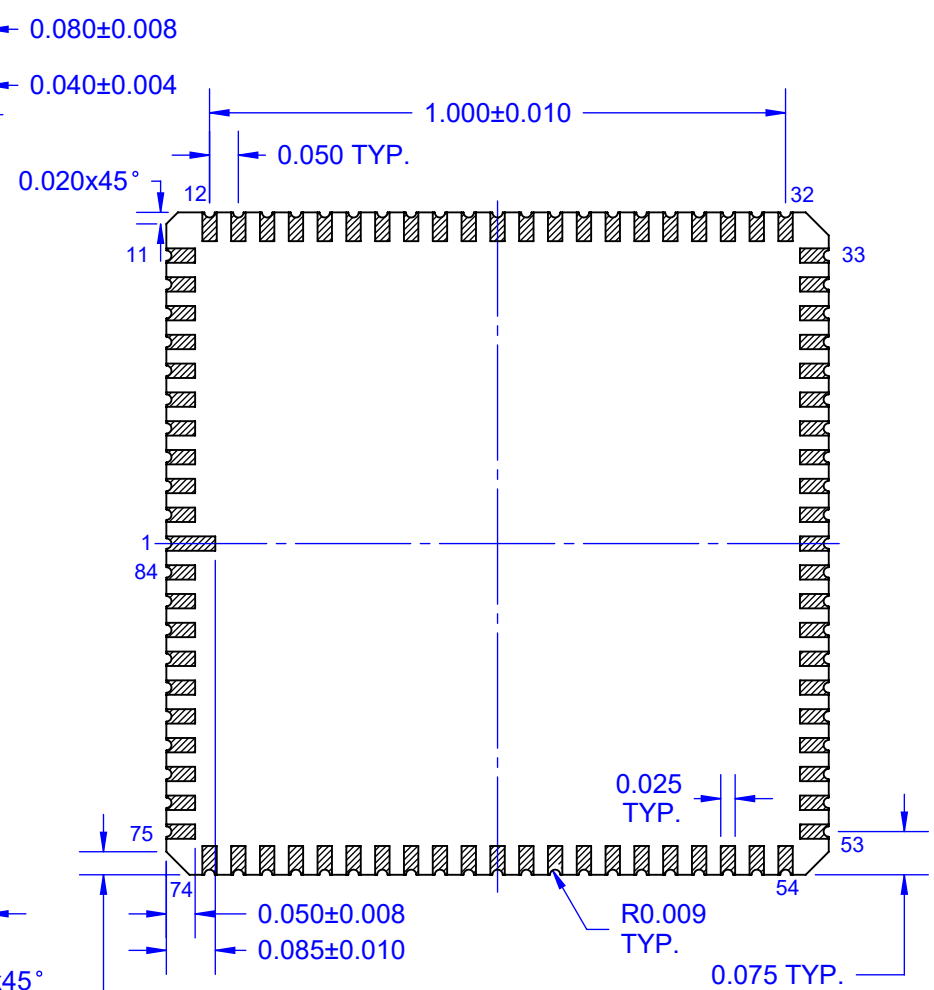

NOTES: (Unless Otherwise Specified).

1) PLATING:

Ni 80 Micro-inch (2.0um) MIN.

Au 60 Micro-inch (1.5um) MIN.

2) DIMENSION in INCH.

PART NUMBER	COVER	PLATING	DAISY CHAIN
LCC84B50SQ1.15-N	OPEN	NiAu	NO
LC84B50SQ1.15	SEALED	NiAu	NO
LCC84B50SQ1.15-SC	SEALED	SnPb	NO
LCC84B50SQ1.15-DE	SEALED	NiAu	YES
LCC84B50SQ1.15-DE-SC	SEALED	SnPb	YES

APPROVALS	DATE				
DRAWN T.Au	06/30/16				
ENG M. Hart	06/30/16	TITLE LCC84B50SQ.1.15			
MFG		SCALE 10:1	SIZE A	DRAWING NO. 148400	REV A
QA					
CUST		DO NOT SCALE DRAWING			SHEET 1 OF 3
REVISED					

LCC84B50SQ1.15-DE DAISY CHAIN

TOP VIEW

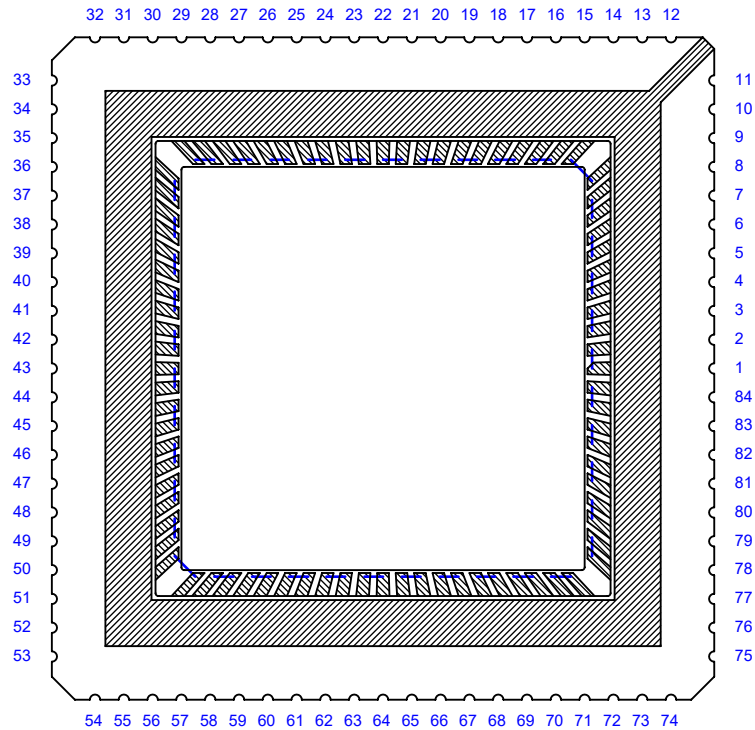

BOTTOM VIEW

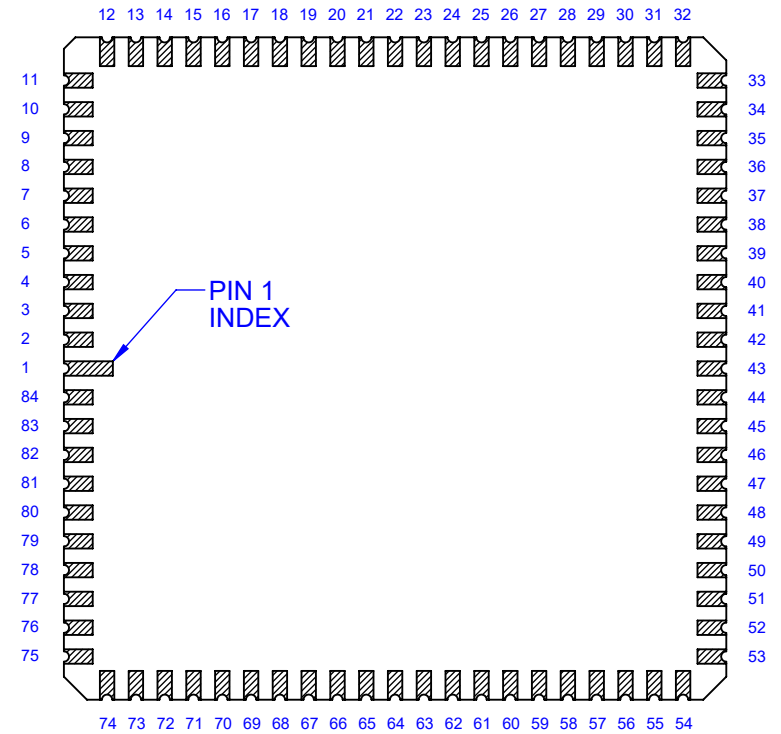

DAISY CHAIN NET LIST

FROM / TO	FROM / TO	FROM / TO	FROM / TO	FROM / TO	FROM / TO	FROM / TO
1 ~ 2	13 ~ 14	25 ~ 26	37 ~ 38	49 ~ 50	61 ~ 62	73 ~ 74
3 ~ 4	15 ~ 16	27 ~ 28	39 ~ 40	51 ~ 52	63 ~ 64	75 ~ 76
5 ~ 6	17 ~ 18	29 ~ 30	41 ~ 42	53 ~ 54	65 ~ 66	77 ~ 78
7 ~ 8	19 ~ 20	31 ~ 32	43 ~ 44	55 ~ 56	67 ~ 68	79 ~ 80
9 ~ 10	21 ~ 22	33 ~ 34	45 ~ 46	57 ~ 58	69 ~ 70	81 ~ 82
11 ~ 12	23 ~ 24	35 ~ 36	47 ~ 48	59 ~ 60	71 ~ 72	83 ~ 84

TopLine[®]

TITLE
LCC84B50SQ.1.15-DE

SCALE 5:1	SIZE A	DRAWING NO. 148400	REV A
--------------	-----------	-----------------------	----------

DO NOT SCALE DRAWING

SHEET 2 OF 3

MODEL

TOP

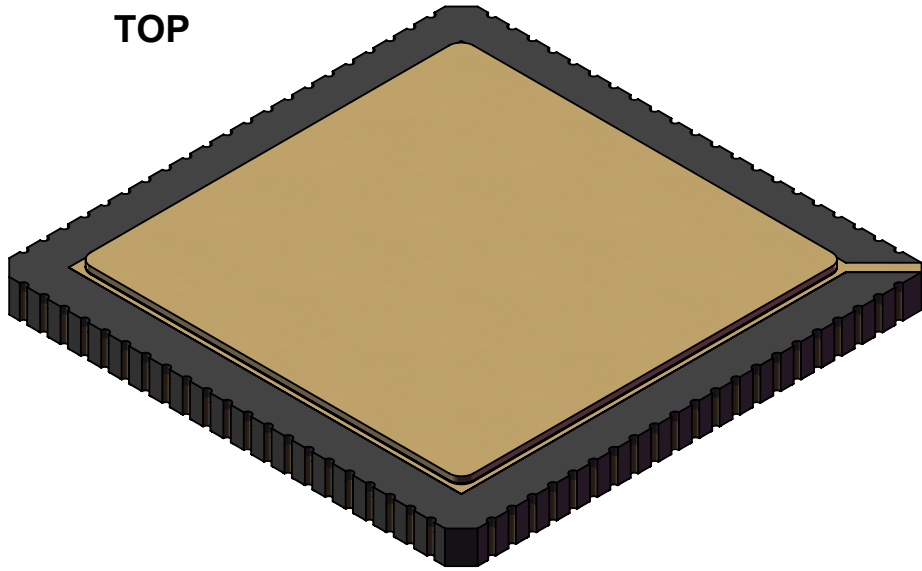

BOTTOM

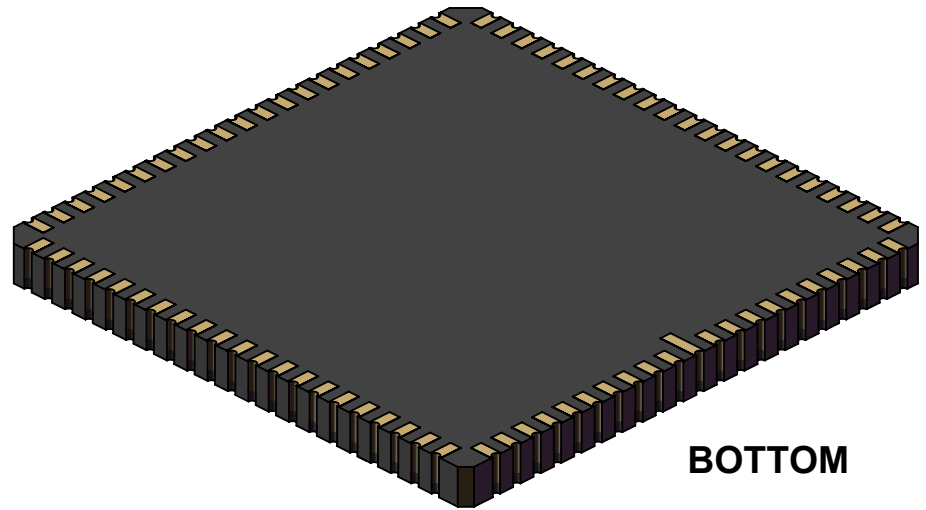

TopLine[®]

TITLE LCC84B50SQ.1.15

SCALE 3:1	SIZE A	DRAWING NO. 148400	REV A
--------------	-----------	-----------------------	----------

DO NOT SCALE DRAWING

SHEET 3 OF 3