

TOP VIEW

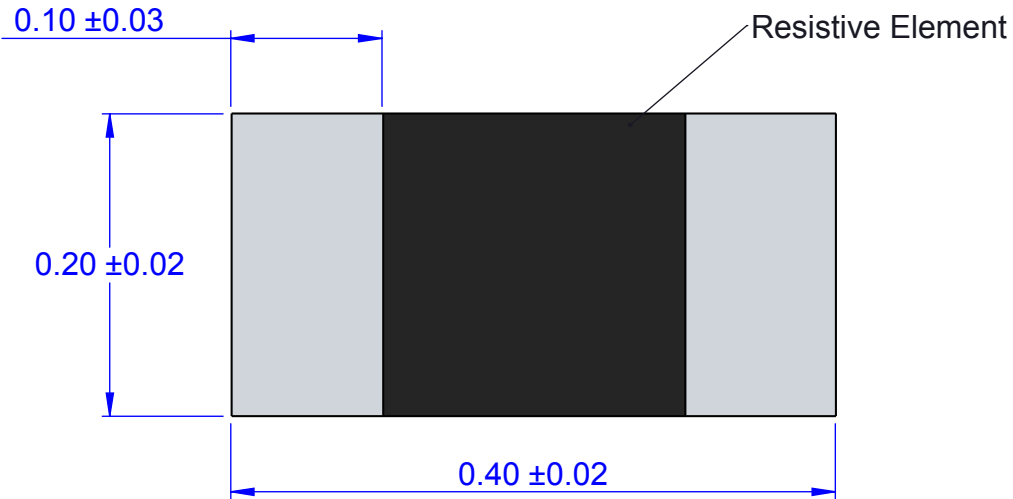

RECOMMENDED PCB PATTERN

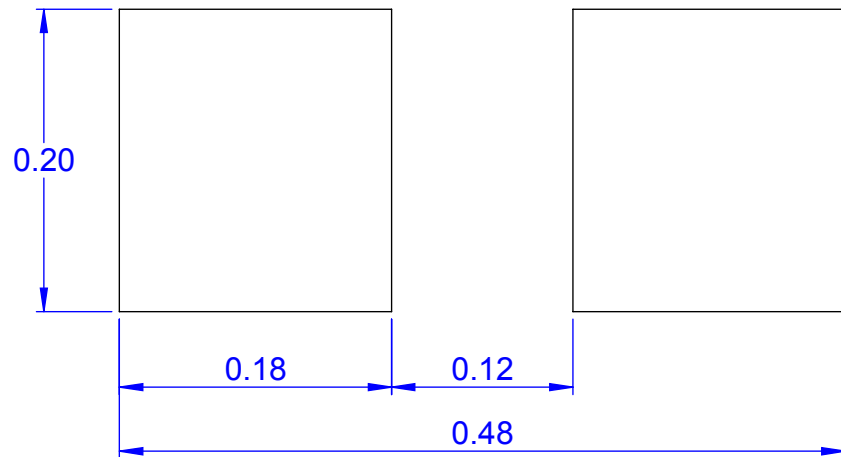

PCB DIMENSIONS ARE PRESENTED ONLY AS A GUIDELINE. DESIGNERS SHOULD USE THEIR OWN KNOWLEDGE BASE WHEN DESIGNING THE PCB.

STRUCTURE

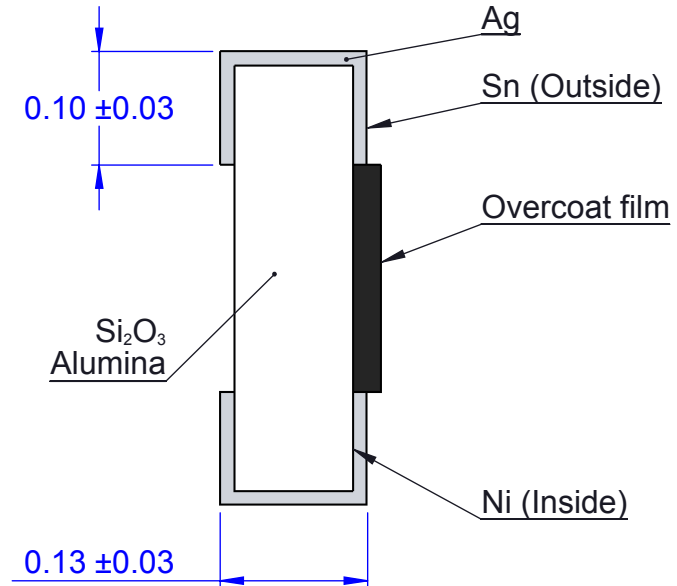

NOTES:

1. DIMENSIONS IN mm.
2. TERMINATION: Tin (Sn).
3. Pb-FREE AND HALOGEN FREE.

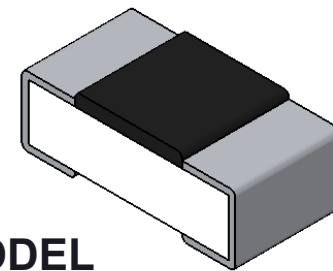

MODEL

APPROVALS	DATE	TopLine®			
DRAWN T. Au	08/03/12				
ENG M. Hart	08/03/12	TITLE SR01005			
MFG		SMT RESISTOR			
QA		SCALE	SIZE	DRAWING NO.	REV
CUST			A	120151	A
REVISED		DO NOT SCALE DRAWING			SHEET 1 OF 3

W8P2 CARRIER TAPE DIMENSION

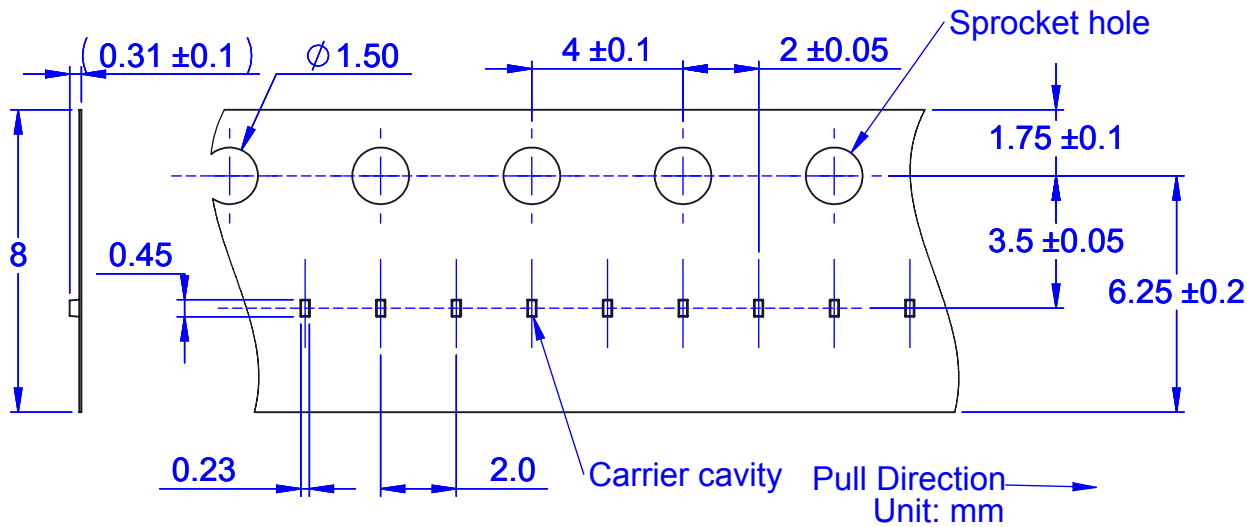

W8P2 TAPE PART NUMBER SYSTEM

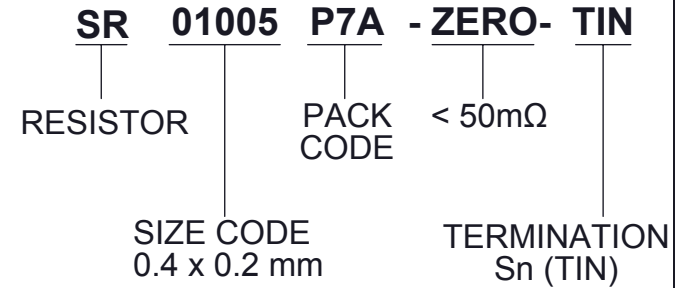

NOTE: For dummy resistor replace ZERO with blank

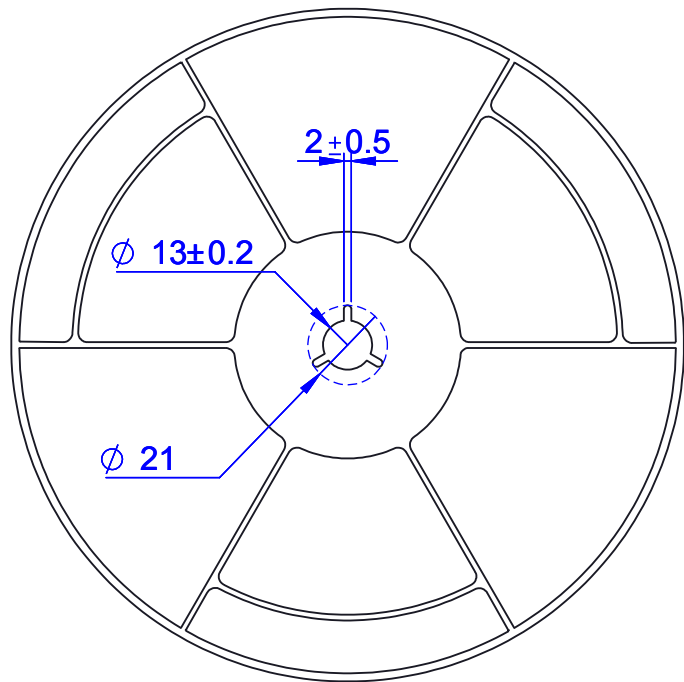

REEL DIMENSIONS

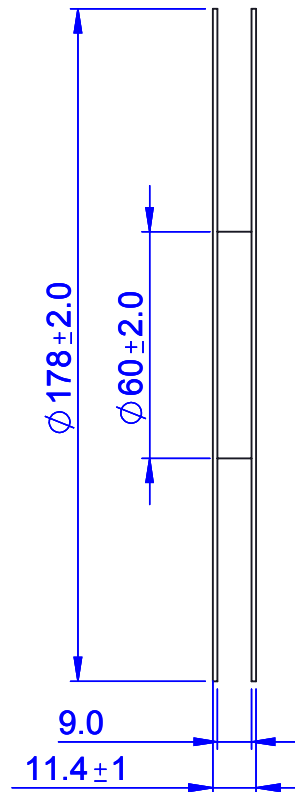

PACK CODE		
CODE	QTY	PACKAGE
P7A	20,000	REEL
P7B	10,000	REEL
P7C	5,000	REEL
P4A	1,000	REEL

APPROVALS		DATE	 SR01005 SMT RESISTOR			
DRAWN	T. Au	08/03/12				
ENG	M. Hart	08/03/12	TITLE			
MFG			SCALE	SIZE	DRAWING NO.	REV
QA				A	120151	A
CUST			DO NOT SCALE DRAWING		SHEET 2 OF 3	
REVISED						

W4P1 CARRIER TAPE DIMENSION

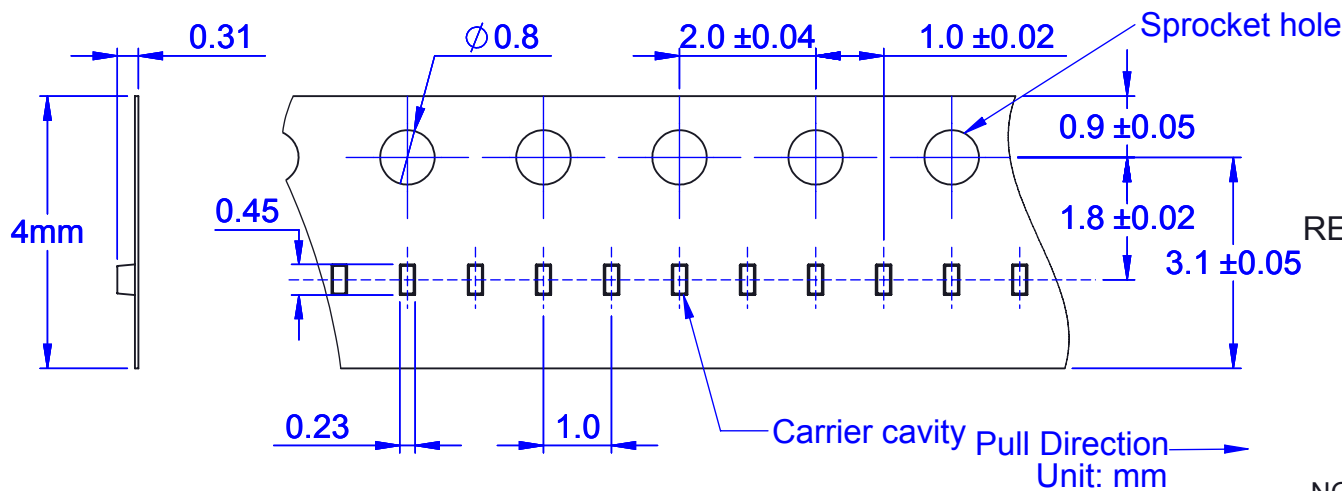

W4P1 TAPE PART NUMBER SYSTEM

SR 01005 E7A - ZERO-W4P1

RESISTOR PACK CODE < 50mΩ

SIZE CODE TAPE

0.4 x 0.2mm Width W4 = 4mm

 Pitch P1 = 1mm

NOTE: For dummy resistor replace ZERO with blank

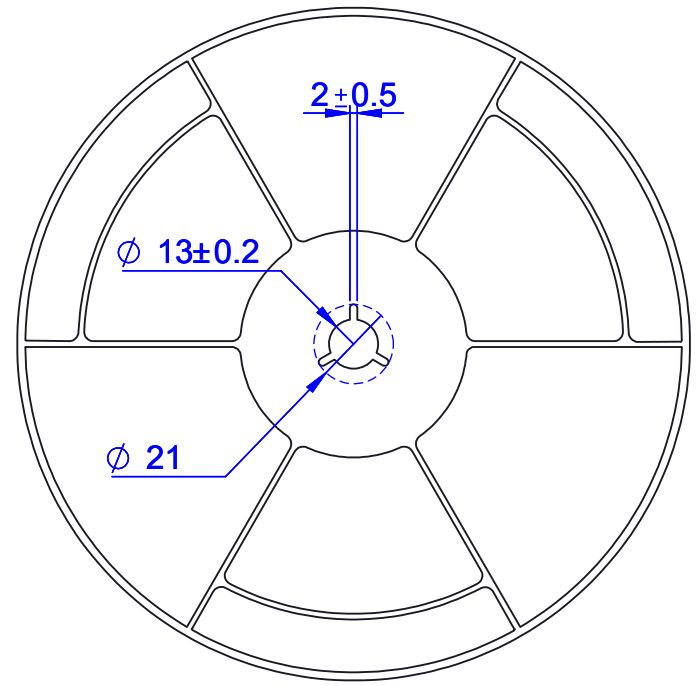

REEL DIMENSIONS

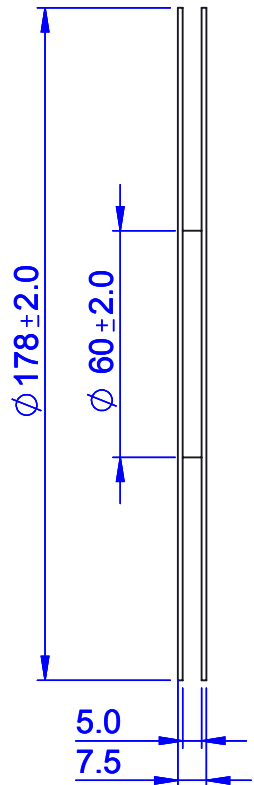

PACK CODE		
CODE	QTY	PACKAGE
E7A	40,000	REEL
E7B	20,000	REEL
E7C	10,000	REEL
E7D	5,000	REEL
E4A	1,000	REEL

APPROVALS	DATE	TopLine®			
DRAWN T. Au	08/03/12				
ENG M. Hart	08/03/12	TITLE SR01005			
MFG		SMT RESISTOR			
QA		SCALE	SIZE	DRAWING NO.	REV
CUST			A	120151	A
REVISED		DO NOT SCALE DRAWING			SHEET 3 OF 3