

TOP VIEW

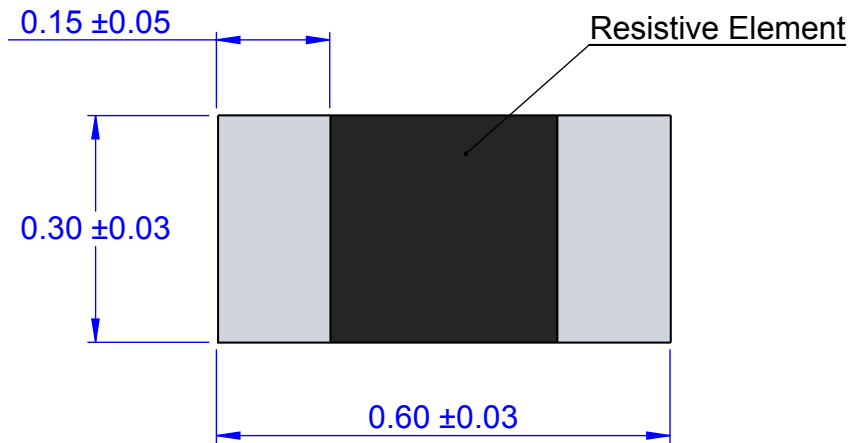

RECOMMENDED PCB PATTERN

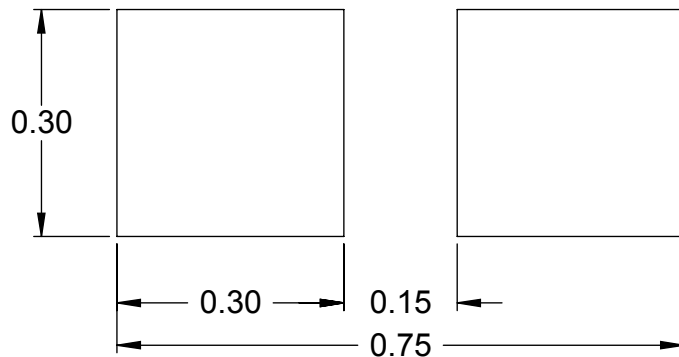

PCB DIMENSIONS ARE PRESENTED ONLY AS A GUIDELINE. DESIGNERS SHOULD USE THEIR OWN KNOWLEDGE BASE WHEN DESIGNING THE PCB.

STRUCTURE

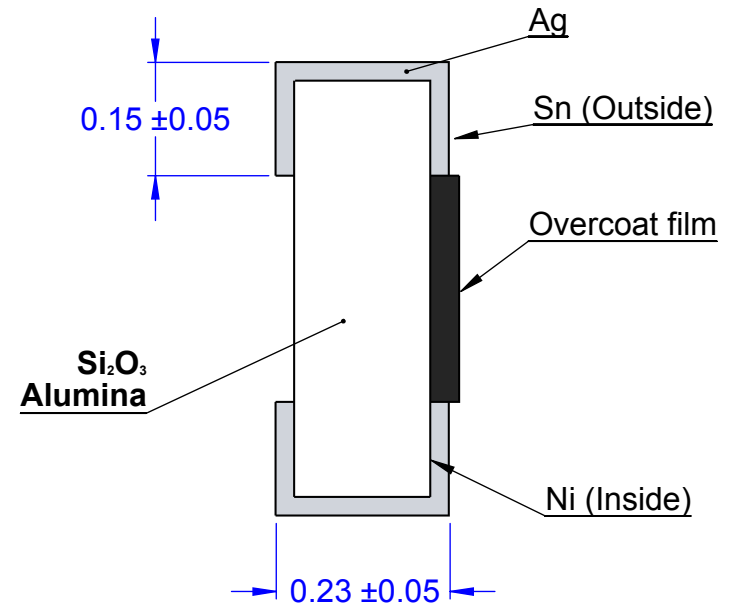

NOTES:

1. DIMENSIONS IN mm.
2. TERMINATION: Tin (Sn).
3. Pb-FREE AND HALOGEN FREE.

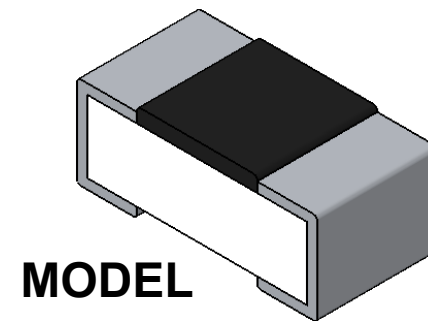

MODEL

APPROVALS	DATE	TopLine®			
DRAWN T. Au	08/03/12				
ENG M. Hart	08/03/12	TITLE SR0201 SMT RESISTOR			
MFG		SCALE	SIZE A	DRAWING NO. 120202	REV A
QA					
CUST		DO NOT SCALE DRAWING			SHEET 1 OF 2
REVISED					

W8P2 CARRIER TAPE DIMENSION

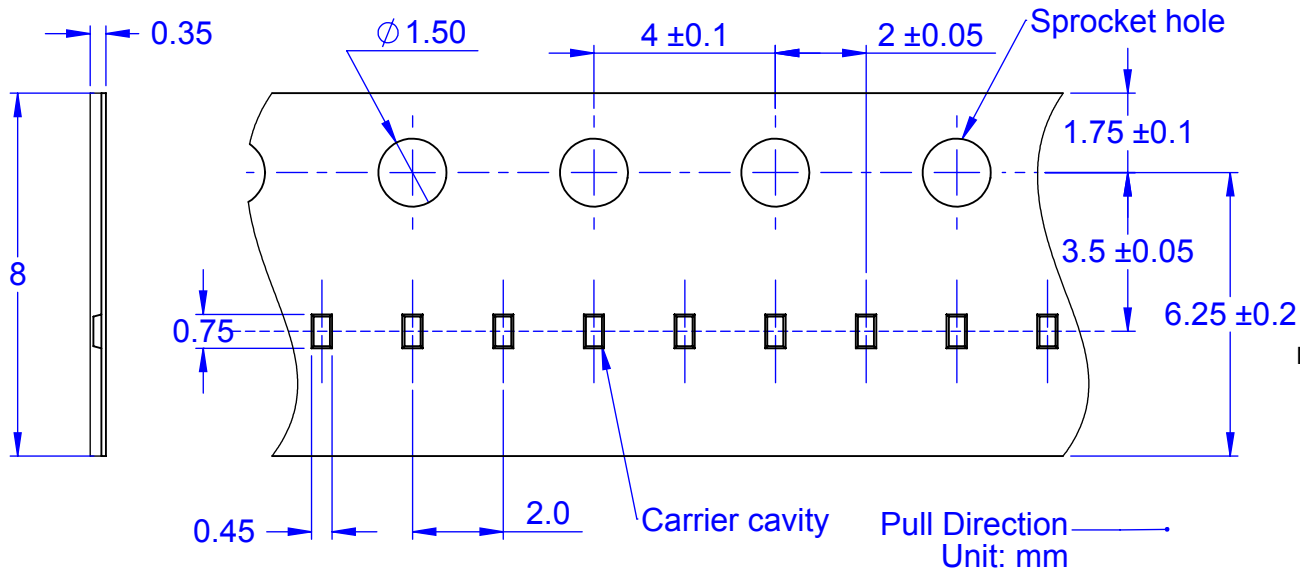

PART NUMBER SYSTEM

SR 0201 P7A - ZERO - TIN

RESISTOR PACK CODE < 50mΩ

SIZE CODE TERMINATION Sn (TIN)

0.6 x 0.3mm

NOTE: For dummy resistor replace ZERO with blank

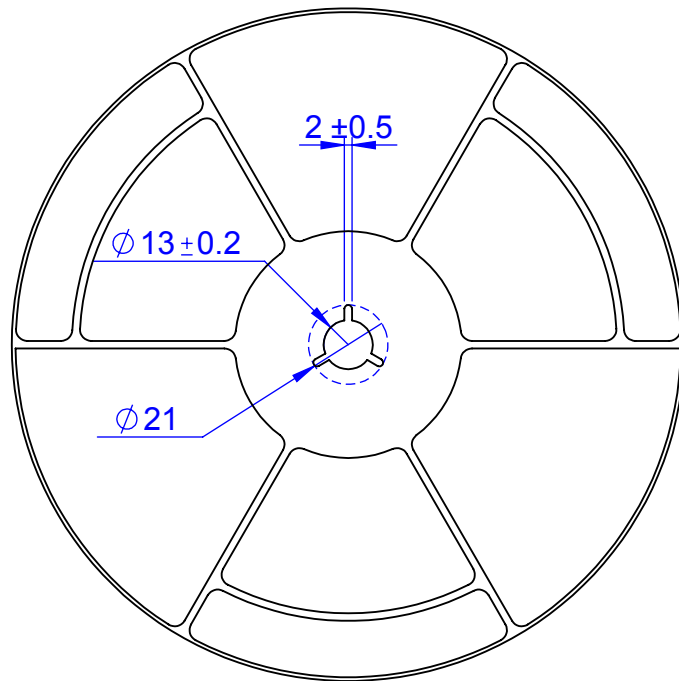

REEL DIMENSIONS

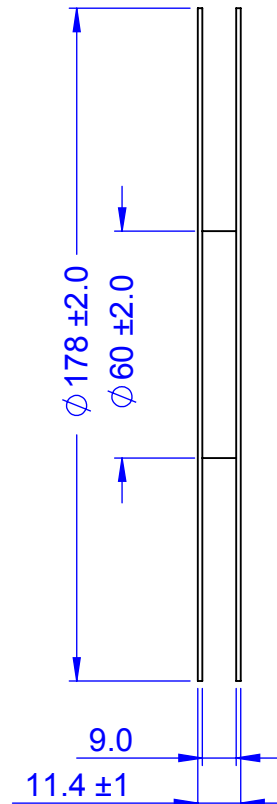

PACK CODE		
CODE	QTY	PACKAGE
P7A	15,000	REEL
P7B	10,000	REEL
P4A	1,000	REEL

APPROVALS	DATE				
DRAWN T. Au	08/01/12				
ENG M. Hart	08/01/12	SCALE SIZE A DRAWING NO. 120202 REV A			
MFG					
QA					
CUST					
REVISED					