

TOP

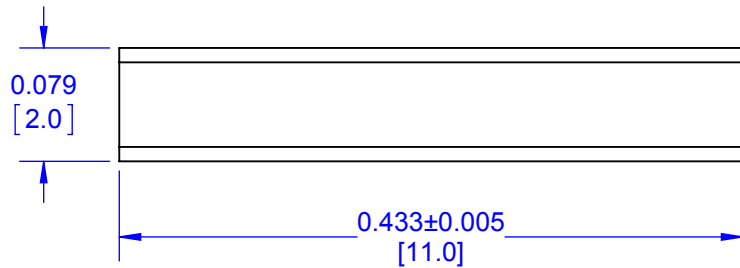

EDGE VIEW

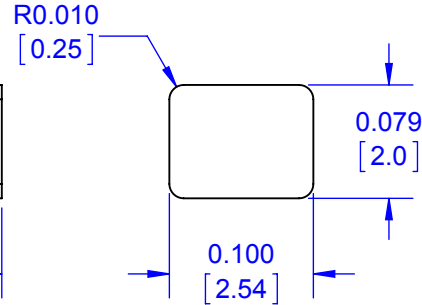

BOTTOM

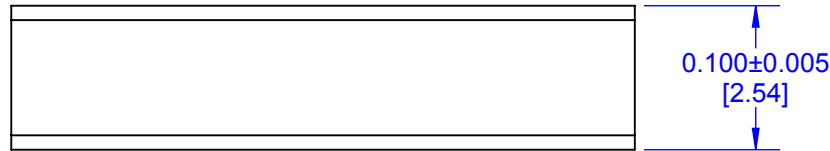
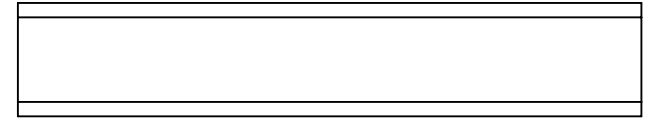

SIDE VIEW

ISOMETRIC VIEW

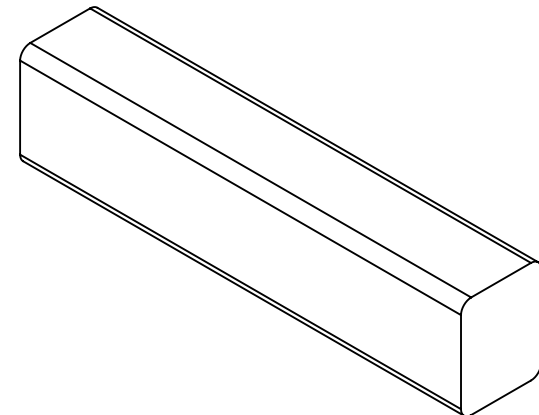

TOPLINE P/N	PLATING	PACKAGING
SSC430810B-T	Sn100	BULK
SSC430810E-T	Sn100	CUT TAPE
SSC430810E7A-T	Sn100	7" REEL
SSC430810E13A-T	Sn100	13" REEL

Notes: (Unless Otherwise Specified)

- 1) BASE: Cu COPPER C101.
- 2) DESCRIPTION: COPPER SLUG.
- 3) PLATING: Sn (TIN) 100-micro-inch (2.54µm).
- 4) DEVICE IS NON-POLARIZED.
- 5) COMPONENT MARKING: NONE.
- 6) Pb-FREE RoHS COMPATIBLE.
- 7) DIMENSIONS: INCH [mm].

APPROVALS	DATE	TopLine®			
DRAWN T. Au	12/01/14				
ENG M. Hart	12/01/14	TITLE SSC430810 PLATED Cu SLUG			
MFG		SCALE	SIZE	DRAWING NO.	REV
QA		7.5:1	A	120012	A
CUST		DO NOT SCALE DRAWING			SHEET 1 OF 3
REVISED					

TAPE SPECIFICATION SURFACE MOUNT DEVICE

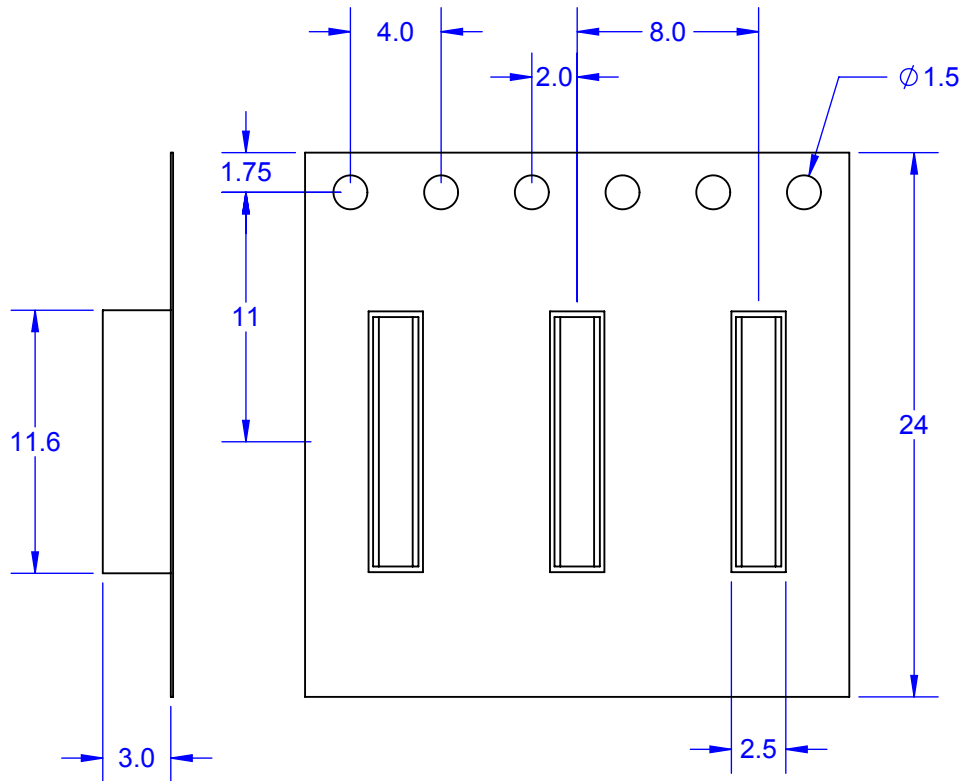

DIRECTION OF UNREELING →

PARTS ARE NON-POLORIZED

7 AND 13 INCH PACKAGE REEL

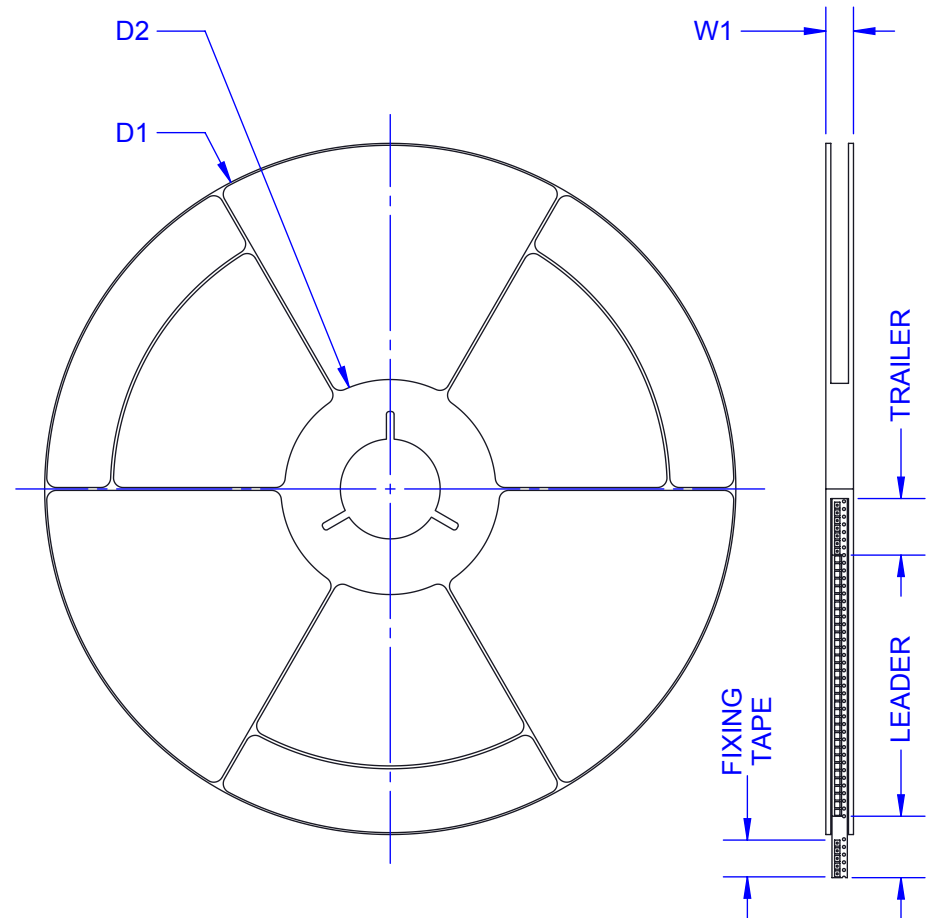

TAPE AND REEL DIMENSIONS		E7A 7-INCH	E7A 13-INCH
REEL DIAMETER	D1	180	330
HUB DIAMETER	D2	62	100
PUNCH HOLE POSITION	F	7.5	7.5
MAX REEL WIDTH	W1	18	18

ALL DIMENSIONS IN mm.

TopLine®			
TITLE SSC430810 PLATED Cu SLUG			
SCALE 7.5:1	SIZE A	DRAWING NO. 120012	REV A
DO NOT SCALE DRAWING			SHEET 2 OF 3

MATERIALS CONTENT DECLARATION FORM
SSC430810 SPACER
 Tin Plated

Component Detail	Material	%	CAS No	Content Weight (grams)	PPM	Percent of Total Weight
Core(Base) Material	Copper C10100	100%	7440-50-8	0.49900	995,933	99.56%
Exterior Plating	Tin(Sn)	99.99%	7440-31-5	0.00204	4,067	0.41%
Total as Shipped (grams)				0.50104	1,000,000	100.00%

PACKAGE TYPE	Copper Spacer
PACKAGE SIZE	11 x 2.0 x 2.54mm
TERMINAL FINISH	Tin (Sn)
Thickness Tin	2.54um 100 Micro-Inch
Total WEIGHT (g)	0.50104
MSL	1

TopLine®			
TITLE		SSC430810 PLATED Cu SLUG	
SCALE	SIZE	DRAWING NO.	REV
7.5:1	A	120012	A
DO NOT SCALE DRAWING			SHEET 3 OF 3